



International Agreement Report

Assessment of RELAP5/MOD3.2-NPA3.4 Against an Inadvertent Closure of all Three MSIV's in VANDELLOS-II Nuclear Power Plant

Prepared by
C. Llopis, A. Tanarro, R.M. Fanegas

TECNATOM
Avda. Montes de Oca, 1,
San Sebastian de los Reyes
28700-Madrid
SPAIN

Office of Nuclear Regulatory Research
U.S. Nuclear Regulatory Commission
Washington, DC 20555-0001

January 2001

Prepared as part of
The Agreement on Research Participation and Technical Exchange
under the International Code Application and Maintenance Program (CAMP)

Published by
U.S. Nuclear Regulatory Commission

NUREG/IA-0197



International Agreement Report

Assessment of RELAP5/MOD3.2-NPA3.4 Against an Inadvertent Closure of all Three MSIV's in VANDELLOS-II Nuclear Power Plant

Prepared by
C. Llopis, A. Tanarro, R.M. Fanegas

TECNATOM
Avda. Montes de Oca, 1,
San Sebastian de los Reyes
28700-Madrid
SPAIN

Office of Nuclear Regulatory Research
U.S. Nuclear Regulatory Commission
Washington, DC 20555-0001

January 2001

Prepared as part of
The Agreement on Research Participation and Technical Exchange
under the International Code Application and Maintenance Program (CAMP)

Published by
U.S. Nuclear Regulatory Commission

ABSTRACT

The work consists in reproducing an actual inadvertent manual closure of all three main steam isolation valves transient that occurred at Vandellós II Nuclear Power Plant (Tarragona, Spain), by means of the RELAP 5/MOD 3.2 code, thus becoming part of an assessment type exercise.

The calculations have been performed by the plant technical support staff and TECNATOM S.A. in a jointly effort. Vandellós NPP input model for RELAP 5/MOD 3.2, has been developed, starting from the input model for the former versions RELAP 5/MOD 2 and MOD 2.5, by the licensee technical services department. The model was provided to TECNATOM S.A., along with the plant data, transient available records and associated information in order to perform the transient calculation and sensitivity studies. Finally, the results and conclusions were discussed and presented jointly by both organizations.

The present report is mainly focused to the steady state and transient calculations and the findings and conclusions derived from them. The general purpose model provided by the licensee, along with some little modifications implemented for the specific transient calculation, are described. A thorough description of the model build-up process is not included.

**ASSESSMENT OF RELAP 5 / MOD 3.2 AGAINST AN INADVERTENT CLOSURE
OF ALL THREE MSIV's IN VANDELLOS II NPP**

TABLE OF CONTENTS

ABSTRACT

EXECUTIVE SUMMARY

1. INTRODUCTION
2. PLANT AND TRANSIENT DESCRIPTION
 - 2.1 Plant Description
 - 2.2 Transient Description
3. CODE INPUT MODEL DESCRIPTION
 - 3.1 Reactor Vessel
 - 3.2 Reactor Coolant System Piping
 - 3.3 Steam Generator Primaries
 - 3.4 Reactor Coolant Pumps
 - 3.5 Pressurizer and Associated Systems
 - 3.6 Steam Generator Secondaries
 - 3.7 Main Feedwater System
 - 3.8 Auxiliary Feedwater System
 - 3.9 Main Steam System
 - 3.10 Emergency Core Cooling System
 - 3.11 Chemical and Volumetric Control System
 - 3.12 Heat Structures
 - 3.13 Reactor Kinetics
 - 3.14 Control System and Trips
4. STEADY STATE CALCULATION AND RESULTS
5. TRANSIENT CALCULATION AND ANALYSIS OF RESULTS
 - 5.1 Transient Calculation Description
 - 5.2 Analysis of Results
6. RUN STATISTICS
7. CONCLUSIONS

FIGURES

FIGURES

- FIGURE 1 Vandellós II NPP model general nodalization for RELAP 5/MOD 3.2.
- FIGURE 2 Reactor Pressure Vessel nodalization
- FIGURE 3 Steam Generator nodalization
- FIGURE 4 Pressurizer and associated piping and valve nodalization
- FIGURE 5 Steam Lines nodalization
- FIGURE 6 Main Feedwater and Auxiliary Feedwater Systems nodalization
- FIGURE 7 Emergency Core Cooling Systems nodalization
- FIGURE 9 Reactor fission power
- FIGURE 10 Pressurizer pressure
- FIGURE 11 Nuclear power
- FIGURE 12 Pressurizer collapsed level
- FIGURE 13 Loop 1 hot leg temperature
- FIGURE 14 Loop 2 hot leg temperature
- FIGURE 15 Loop 3 hot leg temperature
- FIGURE 16 Loop 1 cold leg temperature
- FIGURE 17 Loop 2 cold leg temperature
- FIGURE 18 Loop 3 cold leg temperature
- FIGURE 19 Loop 1 average temperature
- FIGURE 20 Loop 2 average temperature
- FIGURE 21 Loop 3 average temperature
- FIGURE 22 Loops 1, 2, and 3 delta temperature
- FIGURE 23 RCS loop 1 mass flow rate
- FIGURE 24 RCS loop 2 mass flow rate
- FIGURE 25 RCS loop 3 mass flow rate
- FIGURE 26 Steam generator A pressure
- FIGURE 27 Steam generator B pressure
- FIGURE 28 Steam generator C pressure
- FIGURE 29 Steam generator A NR downcomer level
- FIGURE 30 Steam generator B NR downcomer level
- FIGURE 31 Steam generator C NR downcomer level

FIGURE 32 Steam generator A steam mass flow rate
FIGURE 33 Steam generator B steam mass flow rate
FIGURE 34 Steam generator C steam mass flow rate
FIGURE 35 Steam generator A MFW mass flow rate
FIGURE 36 Steam generator B MFW mass flow rate
FIGURE 37 Steam generator C MFW mass flow rate
FIGURE 38 AFW mass flow rates
FIGURE 39 Pressurizer relief valves mass flow rate
FIGURE 40 Pressurizer safety valves mass flow rate
FIGURE 41 Steam generator A relief and safety valves discharged mass
FIGURE 42 Steam generator B relief and safety valves discharged mass
FIGURE 43 Steam generator C relief and safety valves discharged mass

TABLES

TABLE 1 Vandellós II NPP nominal conditions at 100% rated power.
TABLE 2 Vandellós II NPP status at event initiation time
TABLE 3 Steady state calculation key parameter results
TABLE 4 Sequence of events

EXECUTIVE SUMMARY

The work to which this report refers falls within the framework of the CAMP/SPAIN Project, the objectives being those referred to in the CAMP Program itself, in particular, achievement of the capacity required to apply calculation tools supporting the quantitative analysis of transients and operation procedures, as well as joint participation in the international efforts aimed to validate and experience the use of appropriate calculation codes.

The work consisted in using the RELAP 5/MOD 3.2 code to reproduce an actual transient that occurred at Vandellós NPP Unit 2, on 26th June 1989, as a part of an assessment exercise within the framework of the CAMP Program.

Vandellós II is a three loop Nuclear Power Plant (NPP) with 2775 MWt (982 MWe), Westinghouse design, Pressurized Water Reactor (PWR). The NPP project was developed during the 1980s. The first criticality was reached on 14th November 1987 and, after its first connection to the grid on December, it began commercial operation on March 1988.

The transient to be simulated consisted in the inadvertent manual closing of all three main steam isolation valves, producing the reactor and turbine trips on steam generator B low-low level. Several specific plant conditions existing by the time of the event, including the operability of certain systems and some setpoint shifts, along with the operator actions taken affected the key parameter evolutions and have been analyzed.

The agreement between calculation results and plant data was acceptable, taking into account the existing uncertainties in the registered plant data described in this report, and Vandellós NPP model for RELAP 5/MOD 3.2 code has shown itself to be adequate for simulation of plant transients, such as the case dealt with in this study. Nevertheless, as it is described below, it is worth pointing out the convenience of evaluating the applicability of a general purpose model to the particular case, in order to modify or remove as needed the non-suitable sections. For simplicity, as well as computing efficiency, it may be even

advisable to delete those parts which do not have a significant effect on the specific transient calculation and, on the other hand, may produce any kind of problem. For example, in the calculation described herein, this latter was the reason to remove the pressurizer relief tank section from the model.

Concerning the transient calculation statistics, it was run on a Hewlett Packard Apollo Serie 700, Model 735 Workstation, with 99 MHz clock frequency. Maximum time step used throughout the transient calculation was 0.1 seconds, the minimum being 6.25 milliseconds during a 2 seconds period at the transient first stage (figure 43). The 1200 seconds transient calculation required 3405 C.P.U. seconds (figure 44), i.e. a 2.84 overall ratio of C.P.U. time to real time.

INTRODUCTION

The work to which this report refers falls within the framework of the CAMP/SPAIN Project, the objectives being those referred to in the CAMP Program itself, specifically, achievement of the capacity required to apply calculation tools supporting the quantitative analysis of transients, operational procedures, etc..., and joint participation in the international efforts aimed to validate and experience the use of appropriate calculation codes.

The work consists in using the RELAP 5/MOD 3.2 code to reproduce an actual transient that occurred at Vandellós NPP, Unit 2, on 26th, June, 1989. It is a part of an assessment exercise within the framework of the CAMP Program.

The report includes the fundamental key points attained during each of the different stages of the work:

- Identification of the main variables involved in the transient and its different stages.
- Study and review of the reference plant (Vandellós II NPP) general purpose model for RELAP 5/MOD 3.2 code.
- Steady state calculation.
- Implementation of the transient specific features and boundary conditions for the transient calculation, along with the suitable modifications and simplifications to the provided model. Sensitivity studies on the affecting boundary conditions to define the most likely combined evolution of some plant parameters for which records are not available or the registered data seem not reliable enough.

2.1 Plant Description

The transient occurred at Vandellós II NPP, a commercial Westinghouse Pressurized Water Reactor (PWR) owned by two Spanish utilities, ENDESA and IBERDROLA. The Unit went first critical in 1987.

The Nuclear Steam Supply System (NSSS) consists of a reactor and three closed reactor coolant loops connected in parallel to the reactor vessel. Each primary loop is composed of a hot leg, steam generator tubes, crossover leg, main reactor coolant pump and cold leg. An electrically heated pressurizer is connected through a surge line to the hot leg of one of the loops. In addition, certain auxiliary systems, as the Chemical and Volume Control System (CVCS) and the Residual Heat Removal System (RHRS), are also connected to the coolant loops.

The rated power of the reactor is 2775 MWt, electrical output being 982 MWe. The reactor core is made up of Zircaloy-clad slightly enriched uranium dioxide fuel rods in canless assemblies, various internal structures, reactivity control components and core monitoring instrumentation. The core is housed in a reactor vessel through which pressurized light water flows, acting both as moderator and coolant.

48 Rod Cluster Control (RCC) assemblies are used for reactor control. They consist of clusters of 24 cylindrical absorber rods each. The control rods of cadmium-indium-silver (Ag-In-Cd) and a boron compound (B_4C) neutron absorber in stainless steel (SS-304) clads extend full core length when fully inserted. Each control rod moves vertically in its own tubular guide thimble in selected fuel assemblies. Above the core, each cluster of absorber rods is attached to a spider connector and drive shaft, which is raised and lowered by a drive mechanism mounted on the reactor vessel head. Downward trip of the RCC is by gravity.

The Reactor Coolant System (RCS) has three similar loops, each connected to the reactor vessel. Each loop has a Reactor Coolant Pump (RCP) and a Steam Generator (SG). The system also includes a pressurizer with its relief tank, connecting piping and instrumentation lines needed for reactor control and protection.

The Reactor Coolant System transfers the heat released in the core to the steam generator secondary coolant, where the turbine generator set driving steam is produced. The reactor coolant water is borated and demineralized and flows at a rate depending on the reactor thermalhydraulic condition. It also acts as neutron moderator and reflector.

Reactor Coolant Pumps are vertical, centrifugal, Westinghouse model 100D, single stage and shaft-seal type. Each of them is driven by a single speed 7500 HP AC induction motor, mounted over the pump hydraulic section. The pump power supply system is designed in such a manner as to achieve a suitable water flow rate to cool the reactor core under any required condition. A fly wheel connected to the pump shaft provides additional inertia, thus increasing the pump coastdown time period.

The Pressurizer is a electrically heated cylindrical vertical tank connected to one of the reactor coolant hot legs through a surge line. It maintains Reactor Coolant System pressure during normal operation, limits pressure variations during plant load transients, and keeps system pressure within design limits during abnormal conditions.

The Steam Generators are Westinghouse design, model F, with 5626 vertical inconel U-tubes and an expanded upper section that houses integral moisture separation equipment to produce dry steam with a quality of at least 99.75 percent.

Preheated Main Feedwater (MFW) enters the upper part of the steam generator downcomer through several J-nozzles localized in a feedwater ring. Circulation ratio on the secondary side of the steam generator is 3.27 at rated power. The auxiliary feedwater system includes a turbine driven pump and two motor driven pumps. They also inject water into the upper part of the downcomer.

The Secondary Side includes the usual Balance Of Plant (BOP) components: feedwater pumps, main steam lines, safety and relief valves, main steam isolation valves, turbine bypass and trip valves, main steam control valves, turbine, condenser, hotwell, heat exchangers, etc.

Reactor coolant piping, reactor internals and all of the pressure containing and heat transfer surfaces in contact with reactor water are stainless steel clad, except the steam generator tubes and fuel tubes which are Inconel 600 TT and Zircaloy-4, respectively.

The Reactor Control System maintains the programmed average primary coolant temperature by positioning the control rods (short-term reactivity control). Reactivity changes due to burnup of the fuel or neutron poisons (Xenon) build-up are compensated by the operator manually reducing primary system boron concentration. Primary pressure is controlled by means of the pressurizer spray and pressurizer heaters, while pressurizer level is controlled through CVCS makeup and letdown flow rates and pressurizer heaters. The turbine bypass shows the two classical aspects of this particular reactor type: average primary temperature control and secondary side steam pressure control. Level in the steam generator is controlled by means of the Feedwater System (FWS).

Reactor Protection System (RPS) produces the reactor automatic scram when the values of some plant key parameters exceed their predefined setpoints. Plant safety is guaranteed by the RPS and the Engineered Safety Features, which include the containment cooling, spray, isolation and ventilation systems, the main steam lines and main feedwater isolation features, the emergency core cooling system (including three high pressure injection pumps, two low pressure injection pumps and three accumulators) and the auxiliary feedwater system.

The nominal values of the main operating parameters at 100% rated power are listed in Table 1 below :

Total core thermal power	2775 MWt
NSSS total heat output	2785 MWt
Heat generated in fuel	97.4 %
Nominal RCS operating pressure	155.1×10^5 Pa
Pressurizer water level	60 %
Total primary coolant flow rate	13545 Kg/s
Vessel inlet temperature	290.67 °C
Vessel outlet temperature	326.22 °C
RCS average temperature	308.44 °C
Average temperature rise in vessel	35.56 °C
Pump suction temperature	290.55 °C
Steam generator shell side operating pressure	66.46×10^5 Pa
Steam temperature	282.33 °C
Steam generator narrow range water level	50 %
Total steam flow rate (all three SG)	1538.5 Kg/s
Total SG blowdown flow rate (all three SG)	47.78 Kg/s
Total main feedwater flow rate	1586.3 Kg/s
Feedwater temperature	223.89 °C
Steam generator circulation ratio	3.27

TABLE 1 : Vandellós II NPP nominal conditions at 100% rated power

2.2 Transient Description

On June 26, 1986, with Vandellos NPP Unit 2 in operation Mode 1 (power operation) with 989 MWe electrical load, and while performing maintenance works on the remote shutdown panel, a manual main steam isolation signal was inadvertently activated, producing the reactor and turbine trips on steam generator B low-low level.

According to the Scram Analysis Report, by the time of the transient initiation, the following main control systems were available and performing their intended functions in their automatic modes :

- Control rods
- Turbine
- Pressurizer level
- Pressurizer pressure
- Steam generator level
- Main feedwater turbine driven pumps
- Charging flow
- Steam generator relief valves (due to on-going maintenance activities, isolation valves upstream of steam generator A and B relief valves were closed, and were reopened after the reactor trip)
- Turbine bypass (in Tavg. mode)

In addition, primary and secondary main parameters were within their operating normal values at the existing power level. Plant conditions at the time of the event were :

Operation mode	1 (power operation)
Nuclear power	100 % (2775 Mwt)
Output power	989.7 MWe
Rod position	Control bank D 211 steps
Boron concentration	156 ppm
Pressurizer pressure	158.4 Kg/cm ²
Average temperature	308.6 °C
Pressurizer level	58.8 %
Steam generator level	50 %
Operating RCPs	A, B, C
Operating MFW turbine driven pumps	A, B

TABLE 2 : Vandellós II NPP status at event initiation time

According also to the Scram Analysis Report and the transient recorded data, the following actuations were manually or automatically initiated during the transient evolution:

1. Inadvertent manual closure of all three main steam isolation valves (transient initiating event).
2. Reactor and subsequent turbine trips on low-low steam generator B level.
3. Turbine bypass valves opening as design (in Tavg. mode)
4. Pressurizer PORV's opening and proper seating.
5. Steam generator relief valves opening.
6. Opening of the first safety valve in all three steam generators and the second one in steam generator C. Although all these valves seated again properly, the steam generator C first and second safety valves closed at a lower pressure than designed. As a result, a steam leakage through these valves was detected some 11 minutes after the scram. Steam generator C safety valves were observed close approximately 15 minutes after the scram.
7. MFW turbine driven pumps trip, MFW system isolation and subsequent Auxiliary Feedwater System actuation.

Some uncertainties exist regarding operator manual actions and some other automatically controlled actuations during the transient, because of lack of associated registered data or further details addressing these particular issues in the Scram Analysis Report, namely :

- manual control of the pressurizer heaters in order to recover pressure conditions and resulting heater power evolution
- manual control of auxiliary feedwater mass flow rate and resulting flow evolution
- steam generator wide range level evolution (narrow range level was lost early in the transient)
- by the time of the inadvertent closure of the MSIVs from the remote shutdown panel, maintenance activities were being performed on this panel. In order to support these activities, the motor driven isolation valves upstream of the steam generators A and B relief valves were closed and manually reopened several seconds after the scram, but the exact time for the reopening of these valves is not accurately known.
- as it has been mentioned above, according also to the Scram Analysis Report, the steam generator C safety valves 1 and 2 opened as a result of the steam generator pressure increase and seated again properly afterwards, but at a lower pressure than designed, the exact value of this pressure being unknown. As a consequence, a steam leakage through these valves was detected some 11 minutes after the scram. Steam generator C safety valves were observed close approximately 15 minutes after the scram.

Finally, no credit has been taken for some registered data during certain stages of the transient because of lack of reasonableness. For example, plant data regarding steam flow rates after the main steam lines isolation seemed not reliable.

The work described herein was carried out using the RELAP 5/MOD 3.2 code, running on a Hewlett Packard 735 workstation. Graphics results were obtained via a program developed by TECNATOM and adapted to RELAP 5 restart-plot file structure for graphics applications.

The model was developed by the licensee technical services department staff and provided to TECNATOM for the transient calculation. It constitutes the result of a long standing task, during which a previous model for the older version of the code, RELAP 5/MOD 2, was updated and adapted to RELAP 5/MOD 3.2 input requirements, and its scope was enlarged to support a wider range of applications.

The nodalization and control logic were carried out so that it could be used to study a wide range of transients, the aim being to make a general purpose model available, with a range of application as large as possible. Therefore, they include components and control systems which do not affect this specific transient. As it shall be described later, some of these components, namely those representing the pressurizer relief tank and associated rupture disk and piping and the whole MFW model, were removed from the model for the transient calculation. Nevertheless, the originally provided complete model is described herein.

Vandellós II NPP model for RELAP 5/MOD 2.3 contains representative modelling for all major Nuclear Steam Supply System and Engineered Safeguard Features components, along with a substantial portion of the Balance of Plant systems. In general, the one-dimensional, non-equilibrium, two-velocity formulation was applied. Choking model was applied at all junctions where choked flow were expected to occur under some condition. Each loop has been modelled separately, including individual hot leg, steam generator, reactor coolant pump and cold leg modelling. Each of the two HPIS and LPIS trains were modeled separately. Figure 1 shows Vandellós NPP model for RELAP 5/MOD 3.2 nodalization scheme. The input model consists of 381 hydrodynamic volumes, 412 junctions, and 57 heat structures with 279 mesh points.

In addition, a complete general purpose control system was implemented. A interactive control variables set was also added to allow the code being run with the Nuclear Plant Analyzer software.

Kinetics data corresponding to a EOL condition were introduced to use the RELAP 5/MOD 3.2 point kinetics model.

3.1 Reactor Vessel

Reactor vessel nodalization is shown in Figure 2. Flow enters from the cold legs into the reactor vessel downcomer, modeled by means of annulus component 504. The primary reactor vessel flow path is downward through this latter component to the lower plenum, component 506. A small portion of the vessel inlet flow is diverted upward through branch 502, which models the downcomer upper region above the cold and hot legs centerline elevation. It flows into the vessel upper head, single volume 520, through branch component 500. The junction between components 502 and 500 represents the upper reactor vessel bypass nozzles. Water flowing downward through the downcomer annulus into the lower plenum is subsequently split between a main path through the reactor core, pipe component 510, and all the core bypass flow paths, modeled by means of pipe 512.

The upper plenum is represented by branches 518, 516 and 514. In this latter, flow coming down from the upper head joins together with those coming up from the reactor core and core bypass. All the coolant flows exit then the vessel through the outlet nozzles towards the hot legs.

The reactor core, modeled by means of pipe component 510, is divided into six active cells. Heat structures 5101 and 5111 represent the 41448 average fuel pins (157 fuel assemblies containing 264 fuel rods each) and a single hot rod respectively.

3.2 Reactor Coolant System Piping

The nodalization of the hot, cold and crossover legs for each primary loop is shown within the general nodalization scheme in Figure 1. All three hot legs are modeled by means of three branch components each, the only difference being the connection of the pressurizer surge line to the branch component 104 in loop 3. Pump suction or cross-over legs are represented by a pipe component with three cells. The cold leg of each loop are also modeled by means of three branch components. Accumulator discharge piping and both trains of the HPIS and LPIS are connected to the first branch component in each cold leg submodel. Pressurizer spray lines join also the first branch components of loops 2 and 3 with the pressurizer head. Finally, charging flow from the CVCS enters into the first branch of loop 2 cold leg, whereas the letdown is taken from the corresponding branch in loop 1.

3.3 Steam Generator Primaries

Nodalization schemes for all three steam generators are identical. Nodalization for steam generator C is shown in Figure 3. Flow from each loop hot leg enters into the associated steam generator inlet plenum, modeled by means of a branch component (branches 170, 140 and 110 respectively). A pipe component (pipes 111, 141 and 171) , containing 14 cells, represents the 5626 U-tubes of each steam generator. These tubes are lumped into a single component, which volume and flow area are the sum of the volumes and flow areas of the whole tube bundle, while length and elevation are those of an equivalent average tube and the hydraulic diameter is the one corresponding to a single tube. Finally, the outlet plenum is represented by another branch component for each steam generator (branches 172, 142 and 112 respectively).

3.4 Reactor Coolant Pumps

Reactor coolant pumps are represented in the model through pump components 178, 148 and 118, as it is shown in Figure 1. A complete set of homologous curves both for single or degraded flow are entered. Pump performance is in this way expressed in terms of the single phase data and the difference data using a two-phase multiplier that is a function

of void fraction. In addition, neither pump velocity table nor control trip were entered. Instead, a representative table of relative pump motor torque (pump motor torque/rated motor torque) was implemented. Thus, the code solves the torque-inertia equation to calculate the pump velocity, whether the pump is tripped or not (in the former case, considering a null value for the pump motor torque).

3.5 Pressurizer and Associated Systems

Vandellos II model nodalization for the pressurizer and its associated systems is shown in Figure 4. The pressurizer upper head is modeled with branch 406, and the pressurizer cylindrical body and lower head are modeled with 7-cell pipe 404. The upper head has 5 connections : one to the cylindrical body, one to the spray line, one to the common line from which two PORV valves take suction (pipe component 429) and one to each of the three safety valve inlet piping (branches 439, 441 and 442). The surge line is modeled with 5-cell pipe 400, which is connected to the pressurizer cylindrical body through single junction 417 and to loop 3 hot leg at the middle point of branch 104 component.

Each of the model pressurizer spray lines which take suction from loops 2 and 3 include a spray valve (servo-valves 410 and 420) and a single junction (414 and 424), these latter representing the continuous spray. They connect loop 2 and 3 cold legs (namely branch components 150 and 120) to the pressurizer head, by means of pipes 408 and 418 and branch components 412, 422 and 425. Governed by the associated control logic, the spray valves open in response to mild primary coolant overpressurization.

Power-operated relief valves (PORVs) are modelled by motor valve components 426 and 428. Operation of these valves is governed by means of the associated control system as a function of the primary pressure values and trends. On turn, pressurizer safety valves are modeled through servo-valve components 430, 432 and 434. The pressurizer relief tank was originally modeled downstream of both kind of valves by means of 6-cell pipe 427, with its rupture disk, valve 461, connecting it to the containment atmosphere, time dependent volume 462. Nevertheless, because it did not have a significant importance for the specific transient and some problems arose with the incondensable gas model calculation before the

PORV valves opening, all the mentioned components downstream the pressurizer safety and relief valves were removed from the model for the transient calculation.

3.6 Steam Generator Secondaries

The nodalization for the loop 3 steam generator is shown in Figure 3, and it is completely analogous to those corresponding to steam generators A and B, the only difference being the numbering pattern which is also specified within this figura. Modelling of the steam generator primary region was described previously in section 3.3.

As it is shown in Figure 3, main feedwater enters the loop 3 steam generator downcomer annulus at branch component 220, where it is combined with the recirculation liquid flow returning from the separator, component 208, through the downcomer annulus branch 218. The combined flow descends through the downcomer, modeled by means of the vertical annulus component 222 with 4 nodes, and enters the boiler lower region through single junction 226, which represents the path from the downcomer to the boiler.

Valve component 201 connects the lower node of the downcomer annulus 222 to a time dependent volume, in order to model the steam generator blowdown.

The boiler region surrounding the steam generator tube bundle is modeled by pipe component 200 with 7 hydrodynamic cells. There, the heat removed from the core by the primary coolant and transferred to the steam generator secondary side coolant is calculated by means of heat structure 1111, representing the tube walls. Axial cell distribution was made consistent between the primary and boiler regions to make the definition of the associated heat structure easier. In this way, the boiler cells correspond to the upflow and downflow hydrodynamic nodes of the tubes, except in the bend region, where the corresponding tube section is divided into two cells, surrounded by branch 200 seventh cell.

The two-phase mixture exiting the boiler region flows through the mid-steam generator regions, branches 204 and 206, before entering the volume inside the separator cylinders, branch-separator component 208. The separation process in both the swirl vane

separators and the steam dryers is assumed to occur in this component. The separator performance is idealized, not allowing liquid fractions passing through the vapor outlet into the steam dome region unless the separator cylinders volume is completely full of liquid ($VOVER = 10^{-36}$). For the liquid fall back junction, recirculation flow may contain vapor fractions for liquid fractions in the separator volume lower than 0.15 (VUNDER) and is a single phase liquid flow otherwise.

A separator bypass flow path, representing the volume between the outermost steam separator cylinders and the inside of the steam generator shell, is modeled by means of branch component 216. During normal steam generator operation, this region is stagnant and contains the quiescent liquid level.

Steam coming out from the separator enters the steam dryer region, which volume is modeled through branch components 210 and 212. No separator features have been implemented into these components. Finally, the steam flows into the steam dome volume, single volume 214, and exits the steam generator through its steam outlet nozzle, sngljun 224.

All the above description is applicable to the nodalization of steam generators A and B. Only the associated component numbering scheme differs among them.

3.7 Main Feedwater System

The feedwater system included in the general purpose model is shown in Figure 6. It extends from the main feedwater header, time dependent volumes 300 and 310, from which both feedwater pumps take suction, to the steam generator feedwater inlet nozzles. The two main feedwater pumps are explicitly modeled by means of pump components 301 and 311. Check valves at the outlets of these pumps are represented by check-valve components 303 and 313 respectively. Discharges from the two main feedwater pumps are combined before flowing through the high pressure heater, which primary and secondary sides are modeled by means of branch component 321 and time dependent volume 306 respectively, thermally connected through heat structure 3221. A bypass line around this heater is also

modeled, with the associated bypass isolation valve, valve component 341. Components 344, 345, 347, 355, 357, 365 and 367 model the main feedwater lines to the individual steam generators. A main feedwater control valve is modeled for each of these lines, valves 346, 356 and 366. Finally, check valves 348, 358 and 368 are introduced upstream of the connection between these lines and those from the auxiliary feedwater system, to prevent any reverse flow through the main feedwater lines.

Both feedwater flows, main and auxiliary, when operating, enter the steam generators through the corresponding feedwater nozzles (single junctions 373, 363 and 353).

3.8 Auxiliary Feedwater System

The auxiliary feedwater turbine driven pump is modeled through time dependent volume 370 and time dependent junction 371. This latter injects feedwater flow into a header, single volume 359, under demand of the associated control system, and depending on the velocity of the pump driving turbine and on the discharge pressure in the header. Auxiliary feedwater flow splits among three lines to the three steam generators. Each of these lines contains a check valve (valves 324, 325 and 326) and an isolation valve (valves 377, 376 and 375). Downstream of the isolation valves, these lines connect to the ones from the auxiliary feedwater motor driven pumps.

Feedwater make-up from the two auxiliary feedwater motor driven pumps is modeled separately by means of time dependent volumes 350 and 360 and corresponding time dependent junctions 351 and 361. Under demand, flow is injected into the common discharge header, single volume 354, depending also on the existing pressure in it. Water flows then towards the steam generators through three separate lines, each of them provided with a check valve (check valves 329, 328 and 327) and an isolation valve (servo-valve components 374, 369 and 364).

3.9 Main Steam System

Main steam system modeled extends from the steam generator outlet nozzles to the turbine first stage and steam dump lines common discharge header, including all the associated valves. Steam extractions taking suction from the steam header are also modeled, along with those from steam lines 1 and 3 to the auxiliary feedwater turbine driven pump. The whole system is shown in Figure 5.

Single junctions 284, 254 and 224 represent the steam generator outlet nozzles, connecting the steam dome of each steam generator to the associated steam line. Reduced flow areas and added flow losses are defined for these junctions in order to represent the steam flow restrictors at those locations.

The first section of the steam lines between the steam generator outlet nozzle and the connections to the relief and safety valves are represented by 3-cell pipe components 660, 630, and 600 respectively, with different lengths from each other since all three steam lines are not completely symmetrical. Branch components 662, 632 and 602 model the next steam line sections. All lines to the steam generator relief and safety valves are connected to the outlet of these branch components.

Each steam line is provided with a relief valve (motor-valves 668, 638 and 608) and five separately modeled safety valves, which are represented by means of five servo-valve components.

Main steam isolation valves are included downstream branch components 662, 632 and 602 through motor-valve components 664, 634 and 604. The last section of the main steam lines are represented in the model by pipe components 666, 636 and 606, which drive the steam flow from each steam generator to the common steam header, branch component 654.

From the steam header, three flow paths are modeled. The first one models the normal operating steam flow path to the turbine, represented by a pressure boundary condition through time dependent volume 711. This line includes the turbine control and stop valves, which are lumped together into a single valve component, servo-valve 710.

All four steam dump lines to the condenser are explicitly and separately modeled, each of them with its associated valve, servo-valve components 780, 781, 782 and 783. Each of these lines discharge into a separate pressure boundary condition, time dependent volumes 785, 786, 787 and 788.

During normal operation condition, a small portion of the main steam flow entering the steam header is diverted through a third steam header outlet line which represents several steam consumptions, including those to the moisture separator reheaters and the main feedwater turbine driven pumps. The associated flow rate is controlled in the model by valve components 650 and 641 and is discharged into time dependent volume 642.

In addition, steam supply to the auxiliary feedwater turbine driven pump is also modeled by means of trip-valve components 622 and 620, which take suction from the inlet of branch components 662 (steam line 1) and 602 (steam line 3) and discharge into branch component 624. Then, this steam flow passes through servo-valve 626 to a common pressure boundary condition, time dependent volume 628.

3.10 Emergency Core Cooling System

The model of Vandellós II ECCS includes two High Pressure Injection System (HPIS) trains, two Low Pressure Injection System (LPIS) trains and three nitrogen-pressurized accumulators. HPIS and LPIS models are showed in Figure 7.

Both HPIS and LPIS take suction from the refuelling water storage tank, modeled by means of time dependent volume 810. Under demand and depending on the ECCS pumps condition, emergency core cooling water exits this pressure boundary

condition, passes through a common line, branch 816, and is diverted between two lines, branch components 852 and 854, each supplying flow to a HPIS train and a LPIS one.

The two HPIS pumps are separately modeled by pump components 813 and 819, each provided with a check valve, valve components 815 and 821, at their discharge. Downstream of these valves, both trains join together in a shared flow path, provided also with a check valve, valve component 823, before being split into three different pipes, each driving the emergency coolant flow to one loop hot leg and equipped also with a check valve, valve components 829, 830 and 831.

The LPIS trains are quite similar to those of the HPIS described above. Each of them consists of an independent pump, pump components 836 and 841, with a check valve downstream, check-valve components 838 and 843. Both trains share a common flow path, modeled through branch component 845, from which three lines to each RCS loop cold leg are modeled, each provided with a check valve, valve components 846, 847 and 848.

The last sections of the injection lines to the three RCS loop cold legs, branch components 832, 833 and 834, are shared between the HPIS and LPIS.

The model for the accumulators and associated piping and valves can be seen in the general nodalization draw showed in Figure 1. All three accumulator models are essentially identical, each of them comprising an accumulator component (806, 803 and 800), and two discharge pipes which connect the pressurized tanks to the three RCS cold legs through a check valve (valve components 862, 860 and 817) and a isolation valve (motor valves 808, 805 and 802). These latter get open manually or on safety injection signal.

3.11 Chemical and Volumetric Control System

As it is shown in Figure 1, CVCS makeup is modelled through two time dependent volume components (460 and 463), discharging into a common line (single volume 458) through two regulating valves (servo-valves 459 and 464, respectively). Flows coming from both boundary conditions show different boron concentrations, and get mixed in the

shared discharge line which drives them to the loop 2 cold leg after passing through an isolation valve, valve component 455.

CVCS letdown, on turn, is modeled through a flow boundary condition, time dependent junction 450, which takes suction from RCS loop 1 cold leg and discharges to time dependent volume 440. The discharge flow is estimated depending on the discharge orifices manually opening and on the pressurizer level.

3.12 Heat Structures

Fuel rods are modeled through heat structures 5101 and 5111. Heat structure 5101 represents the average rod condition, which is applied to all the 41448 fuel rods in the core (157 fuel assemblies containing 264 fuel rods each), with 4354.8 m² heat transfer area. Heat structure 5111 represents a single hot rod, with a hot channel factor of 1,43. Both heat structures are defined with 6 axial nodes (one per each associated hydraulic node) and 5 radial mesh points. The first two intervals between mesh points represent the fuel (UO₂), their power source being calculated by the point kinetics model. The third interval represents the gap and the last one the clad (Zircaloy-4).

Heat structures 1711, 1411 and 1111 model the heat transfer between the primary and secondary coolant through the tube walls of steam generators A, B and C respectively. All of them are defined with 14 axial nodes and 5 radial mesh points and represent the 5626 tubes in each steam generator (no steam generator tube plugging is considered), with a total heat transfer area of 5085 m² per steam generator. The convection and boiling correlations for vertical tube bundles without cross-flow were selected both for the inner and outer tube wall surfaces.

Pressurizer heaters are modeled through heat structure 4041, which transfer the heater power calculated by control variable 178 to the coolant in the pressurizer model (pipe component 404) two lower cells. No heat losses through the pressurizer walls are considered.

Finally, Main Feedwater Heat Exchanger is modeled by means of heat structure 3221, which calculates the heat transfer from time dependent volume 306 to the feedwater in branch 321. This heat structure was deleted, along with the rest of the main feedwater model provided, when this latter was simplified by directly introducing the actual transient main feedwater flow recorded data by means of boundary conditions.

All the above mentioned heat structures include 57 axial nodes and 279 radial mesh points.

3.13 Reactor Kinetics

Concerning the core, the code point kinetics model is used, with feedback due to moderator density and volumetric average fuel temperature, introduced through separate tables and affected by the associated volume density and fuel temperature weighting factors respectively. Decay of standard fission products is also considered. Total reactor power (fission power plus fission product decay power) is 2775.41 MWt. EOL condition values for the delayed neutron fraction (β) and prompt neutron generation time (Λ), along with those for the delayed neutron precursor yield ratios (β_i) and decay constants (λ_i), are used.

Selected fission product data are those defined in the 1979 ANS Standard for ^{235}U . Initial conditions for fission product are the ones corresponding to operation at the defined power level for a 1000 hours period time.

Feedback reactivity (ρ) due to moderator density (kg/m^3) and fuel temperature ($^{\circ}\text{K}$) are introduced by means of tables of these parameters versus reactivity (ρ), $R_p[\rho_i]$ and $R_F[T_{Fi}]$. In addition, for each specific hydrodynamic cell a volume weighting factor W_{ρ_i} is applied to the moderator density reactivity table resulting value, while analogous fuel temperature $W_{T_{Fi}}$ weighting factors defined for the associated heat structure axial node are applied to the fuel temperature reactivity table.

Finally, scram reactivity is introduced through table 850, whereas control rod and boron reactivity are assessed and introduced through control variables 140 and 749 respectively.

3.14 Control System and Trips

The model has been completed by including the following plant control and protection systems by means of RELAP 5 trip and control variable provided scheme :

- Average temperature (rod control)
- Pressurizer pressure and level
- Steam generator level (main feedwater valves and turbine driven pumps control system)
- Auxiliary feedwater control system
- Steam generator relief and safety valves
- Turbine and steam dump control
- Reactor trips and AMSAC
- Turbine trips
- Permissives
- Safety injection

The complete control and protection systems include 753 control variables, 247 variable trips, 372 logical trips and 101 general tables.

The steady state at 100 % rated power level conditions was directly calculated with the model provided by the licensee and described above. The steady state condition achieved was subsequently used as the initial condition for the transient, by means of the code dump-restart feature. Key plant parameter values obtained at the end of the steady state calculation, which took 2000 seconds problem time (5186 seconds CPU time consumption with a maximum time step size of 0.1 seconds), are listed below in Table 3 and compared with the actual plant recorded data and nominal values. These latter are taken from the Final Safety Analysis Report, the Process Diagrams, and the document WTP-ENG-TN-81-001 "Model F Steam Generator Thermal Hydraulic Report", while the actual plant data are those obtained as time averaged values of the recorded data just before the transient initiation.

As it can be seen, a overall good agreement was achieved between the steady state calculation results and the actual plant conditions by the time of the event. It must be noted however that these recorded data are not completely consistent (for example, the recorded values of the core thermal power, temperature rise in vessel and total primary mass flow rate do not match the vessel thermal balance). Therefore, because of lack of data to analyze the plant instrumentation measurement errors, the steady state condition reached was considered an acceptable compromise initial condition for the transient calculation. However, as it is described later, the small discrepancies between some of the steady state calculation results with respect to the plant data could be the reason for some differences between the recorded and the calculated transient evolutions of certain variables, in particular those corresponding to the steam generator secondary side pressure. In addition, it should be mentioned that the discrepancy between the calculated and measured reactor coolant flow values may arise, to a considerable extent, from the fact than volumetric flow rates are measured at the plant and then compared to a reference 100 % value to obtain the percentage readings. Because no exact data were available about this reference value neither regarding under which conditions it was defined (in order to relate volumetric and mass flow rates), the mass flow rate included in table 3 reference values column was taken as 100 % mass flow rate, but the accuracy of this assumption may not be assured.

VARIABLE	REFERENCE VALUE	RECORDED DATA	RELAP 5 MOD 3.2
Total core thermal power (MWt)	2775	2788 (N0049: 100.5%)	2794.93 (RKTPOW / 10 ⁶)
NSSS total heat output (MWt)	2785	-	2804.87 (CNTRLVAR 921+922+923)
Heat generated in fuel (%)	97.4	-	100.0 (HS 5101, 5111)
Nominal RCS operating abs. pressure (bar)	155.1	156.6 (P0480)	155.16 (P 406010000)
Pressurizer water level (%)	60	59.15 (L0480)	59.87 (CNTRLVAR 146)
Total primary coolant flow rate (Kg/s)	13545	13441.15 (Avg. F0400/20/40 : 99.23%)	14115.2 (MFLOW 18801+15801+12801)
Vessel inlet temperature (°C)	290.67	292.33 (Avg. T0650/70/90)	292.04 (Avg. CNTRLVAR 47, 45, 43)
Vessel outlet temperature (°C)	326.22	324.87 (Avg. T0651/71/91)	326.22 (Avg. CNTRLVAR 46, 44, 42)
RCS average temperature (°C)	308.44	308.6 ($(T_{\text{hot}} + T_{\text{cold}})/2$)	309.13 (Avg. CNTRLVAR 112, 111, 110)

TABLE 3 : STEADY STATE CALCULATION KEY PARAMETER RESULTS

VARIABLE	REFERENCE VALUE	RECORDED DATA	RELAP 5 MOD 3.2
Average temperature rise in vessel (°C)	35.56	32.54 ($T_{hot}-T_{cold}$)	34.18 (Avg. CNTRLVAR 533, 523, 513)
Pump suction temperature (°C)	290.55	-	291.77 (Avg. TEMPF 176, 146, 116)
SG shell side operating abs. pressure (bar)	66.46	67.7 (Avg. P0400/20/40)	67.92 (Avg. P 66001, 63001, 60001)
SG narrow range water level (%)	50.0	50.8 (Avg. L0400/20/40)	50.0 (Avg. CNTRLVAR 257, 234, 210)
Total steam flow rate (Kg/s)	1538.5	1530.4 (F0405 + F0425 + F0445)	1544.37 (MFLOW 66001 + 63001 + 60001)
Total SG's blowdown flow rate (Kg/s)	15.39		17.49 (MFLOW 26100 + 23100 + 20100)
Total main feedwater flow rate (Kg/s)	1586.3	1558.4 (F0403 + F0423 + F0443)	1561.8 (MFLOW 26600 + 35600 + 34600)
Feedwater temperature (°C)	223.89	224.63 (Avg. T7503/04/05)	223.89 (Avg. TEMPF 37201, 36201, 35201)
Steam generator circulation ratio (-)	3.27	-	3.31 (CNTRLVAR 701)

TABLE 3 : STEADY STATE CALCULATION KEY PARAMETER RESULTS (Cont.)

In addition to the small discrepancies observed between the calculated and the recorded parameter values, a significant feature dealing with the void fraction distribution in the boiler cells which affected the steam generator secondary mass distribution was observed. The void fraction increased from volume to volume up to the boiler region (7-cell pipe 200) fifth cell, where it dropped below that of the fourth cell, increasing again when ascending across the remaining upper cells. It was observed that the code predicted a slug flow regime in the first five cells and then an annular-mist flow in the upper ones. Consequently, it is thought that the described anomalous result had to do with the flow regime transition. It could be produced by the different interphase frictions between both regimes, which would lead to less liquid being carried over in the upper cells towards the separator volume.

It is worth to point out that, when investigating this circumstance, the same code behaviour was also observed in the typical PWR model provided with the code as a sample problem (typpwr.i). Other sources consulted in this regard also referenced this matter but did not provide suitable solutions.

5.1 Transient Calculation Description

Transient calculation was conducted by means of a "restart" calculation, with transient option, starting from the conditions of the last dump generated in the steady state calculation. Given that this calculation was also performed with the transient option, an intermediate calculation was carried out with the steady-state option and 1 second calculation time. In this way, a significantly shorter restart-plot file containing the desired transient initial conditions in its first dump was generated, and problem time was automatically reset to zero at the beginning of the transient calculation.

Thus, the initial transient conditions are those previously obtained from the steady state calculation, which are described in chapter 4 above. Conditions and perturbances constituting the event root causes and plant specific status by the time of the event, along with some ad-hoc suitable modifications and simplifications to the provided model are introduced in this restart input file. The calculated problem time was 1200 seconds, including a 154 seconds initial period under "null transient" conditions (steady state or no perturbation conditions).

The initiating event was implemented by substituting the interactive input variables in the MSL's isolation valves governing logic (used for the manual closing of these valves when running the code with the Nuclear Plant Analyzer software), for time tables, which produced the valves closing at time 154 seconds into the calculation, closing time being 1 second.

Operator assumed manual actions and specific plant conditions affecting the transient evolution were implemented in the following way :

- three time tables were defined, in order to apply a time dependent factor to the auxiliary feedwater mass flow rate calculated by the model. It allowed to simulate the operator manual control over the AFW makeup.

- a similar time dependent factor was introduced to prevent the opening under demand of the steam generator A and B relief valves for a defined time period after the reactor trip. The objective was to reproduce the effect of the isolating valves downstream of these relief valves which, according to the Scram Analysis Report, were closed by the time of the trip to support maintenance activities and were reopened afterwards.
- trips and control variables defining the pressure close setpoints of steam generator C safety valves 1 and 2 were modified, in order to model the reported shift of these setpoints.

Some model modifications and minor corrections were also implemented for the transient calculation through the restart input file. In addition, several suitable simplifications were introduced, the most significant being :

- because the model region downstream of the pressurizer safety and relief valves did not have a significant importance for the specific transient and, during the initial runs, some problems arose with the incondensable gas model calculation even before the PORV valves opening, all the involved components within this region were removed from the model and replaced by five time dependent volumes representing the pressurizer relief tank conditions at valve discharges.
- when first running the transient with the MFW model and associated control logic included in the provided model, calculation results and recorded data showed significant discrepancies regarding MFW mass flow rates evolution during the transient first stages. These discrepancies were attributed to some modifications introduced in the plant MFW control logic parameters (gains) after the event date (June 26, 1986), which were, on turn, implemented into the model itself, resulting in a different response of the updated model with respect to the old plant MFW control system. Given that the model of the MFWS and associated control logic corresponding to the parameter old values was not directly available to TECNATOM by the time calculation activities were carried

out, and both old and current MFW models had been extensively tested by the licensee, it was concluded that additional assessment on this subject was worthless and, consequently it was decided not to implement again the old model. Instead, MFW model was substituted for three time dependent volume components associated to a time dependent junction each, in order to directly introduce the MFW mass flow rate registered data as a boundary condition.

Finally, a set of control variables were introduced to convert some calculated parameters into the units used in the plant data, in order to make their comparison easier. In addition, integral type control variables were introduced to evaluate the secondary valve discharged masses.

5.2 Analysis of Results

Transient results are shown in figures 8 to 44, most of which showing the calculation result plots (in wide line) compared with the associated plant instrumentation recorded data (in narrow line) for the fundamental variables. This set of variables was chosen based on their importance to the transient evolution. Additionally, it must be pointed out that the variables evolution introduced as boundary conditions, i.e. the main feedwater flow to all three steam generators, are also obtained from plant data. Consequently, the associated analytical and recorded plots completely match each other.

Table 4 shows the sequence of the most important simulation events with RELAP 5/MOD 3.2

EVENT	PLANT RECORDED DATA	RELAP 5/MOD 3.2
MSL isolation	154 s.	154 s.
PRZ. PORV's 1 and 2 opening/closing		160 s. / 167 s.
SG's 1, 2 NR low-low level (16 %)		162.4 s.
Reactor trip (on SG NR low-low level)	160 s.	162.4 s.
AFW initiation (100 % AFW flow : 94 Tm/h per SG aprox.)		162.4 s.
PRZ. maximum pressure	160.5 s. (164.4 Kg/cm ²)	164 s. (164.4 Kg/cm ²)
SG's 1, 2 relief and safety valves opening/closing relief valves (SG-1, SG-2) safety valves 1 safety valves 2 safety valves 3		164 / 386, 416 s. 166 / 188 s. 166 / 184 s. 168 / 180 s.
SG 3 relief safety valves opening/closing relief valve safety valve 1 (reduced setpoint) safety valve 2 (reduced setpoint) safety valve 3		162 / 282 s. 166 / 630 s. 166 / 196 s. 168 / 180 s.
AFW flow step reduction (from 94 Tm/h per SG to 83 Tm/h aprox.)		555 s.
AFW flow step reduction (from 83 Tm/h per SG to 59 Tm/h aprox.)		755 s.

TABLE 4 : Sequence of events

Event root disturbance, close of all three steam line isolation valves, is introduced at time 154 seconds into the calculation, thus interrupting the steam flow to the turbine (figures 31, 32 and 33) and resulting in a sudden steam generator pressure increase (figures 25, 26 and 27), up to the secondary safety and relief valves open setpoints. In particular, according to the calculation results, relief valves and safety valves 1, 2 and 3 in all three steam generators get opened between 162 and 168 seconds into the calculation (figures 40, 41 and 42).

One of the main discrepancies between the analytical results and the transient reported data is the number of safety valves which were opened. As it has been described, according to the calculation results, secondary pressure increases up to the third safety valve open setpoint, thus producing three valves to lift in all three steam generators, while, according to the Scram Analysis Report, only the first valve in steam generators A and B and the first and second valves in steam generator C got open in the actual transient. The reason for this discrepancy may be, to a considerable extent, the higher secondary pressure obtained in the steady state calculation and used as initial condition for the transient calculation, leading to a calculated pressure maximum which slightly exceeds that recorded in the real transient.

As a consequence of the steam flow interruption, the steam generator function as RCS heat sink becomes degraded, thus producing primary coolant pressure (figure 10) to increase, reaching a maximum value of 164.4 Kg/cm² at 164 seconds time, and pressurizer both PORV's to lift (figure 38).

Degradation of heat removal by the steam generators has a significant effect on cold leg temperatures (figures 15, 16 and 17), which experiment a steep increase and show a maximum value of 303 °C at 170 seconds, when the reactor trip stops this temperature excursion. Hot legs temperature increase (figures 12, 13 and 14) is quite lower.

In addition, MSL isolation leads to a MFW flow reduction (figures 34, 35 and 36) which, on turn, results in steam generator downcomer narrow range level to decrease (figures 28, 29 and 30). At time 162.4 seconds into the calculation, steam generator A and

2 low-low level setpoint (16 %) is reached, thus producing the reactor being automatically tripped (figure 9). This condition (1/3 steam generator low-low level) also causes the AFW initiation at time 162.4 seconds (figure 37)

Reactor trip leads to the turbine trip and the turbine valve closing as well as the turbine bypass valve opening in average temperature mode. Both automatic actions have no effect over the RCS and steam generator secondary side conditions since Main Steam Lines are isolated.

On reactor trip, RCS pressure and temperature increasing trends are removed, and the overall system conditions become controlled by the secondary side conditions as far as these latter determine the steam generator efficiency as RCS heat sink.

Therefore, from reactor trip on, secondary side thermalhydraulic conditions are determined by the combined effects of the auxiliary feedwater mass flow and the secondary side valves opening. In this sense, as it was described in item 2.2, significant uncertainties existed regarding the AFW mass flow rate evolution and the secondary valves performance. Namely :

- no recorded data were available on the auxiliary feedwater mass flow rate evolution under manual control, neither could it be estimated through sensitivity studies on the WR level evolution because of lack of recorded data on this latter (narrow range level was lost early in the transient)
- by the time of the inadvertent closure of the MSIVs from the remote shutdown panel, maintenance activities were being performed on this panel. In order to support these activities, the motor driven isolation valves upstream of the steam generators A and B relief valves, were closed and manually reopened several seconds after the scram, but the exact time for the reopening of these valves is not accurately known.
- steam generator C safety valves 1 and 2 opened as a result of the steam generator pressure increase and seated again properly afterwards, but at a lower pressure than

designed, the exact value of this pressure being unknown. As a consequence, a steam leakage through these valves was detected some 11 minutes after the scram. Steam generator C safety valves were observed close approximately 15 minutes after the scram.

Therefore, sensitivity studies were focused on adjusting the secondary pressure evolution to the recorded data through the combined effect of manual step reductions of the AFW flow rate and the shift of steam generator C safety valves 1 and 2 close setpoints. In this way, steam generator calculated pressures were eventually adjusted to the recorded values by reducing the mentioned setpoints in 2.5 bars (safety valve 1 close setpoint becomes lower than relief valve setpoint), and introducing two step reductions to the AFW flow rates at time 555 seconds (from 94 Tm/h per SG to 83 Tm/h approximately) and 755 seconds (from 83 Tm/h per SG to 59 Tm/h approximately) respectively. On the other hand, steam generator A and B relief valves were considered operables from the reactor trip on, that is, it was assumed that the isolation valves upstream of the mentioned relief valves, which were closed to support maintenance activities as it has been described above, were reopened on reactor trip.

The manoeuvre to manually reduce the AFW flow rate, is justified in order to prevent a safety injection actuation on low pressurizer pressure (setpoint : 128.018 bar) because of an excessive RCS cooldown through the steam generators.

RUN STATISTICS

The calculation has been performed using the RELAP 5/MOD 3.2 code, running on a Hewlett Packard Apollo Serie 700, Model 735 Workstation.

- ☐ Control processor PA-RISC 7100
- ☐ Clock frequency 99 MHz
- ☐ Performance:

SPEC marks 89	147
MIPS	124
MFLOPS	40
SPECint92	80
SPECfp92	150
- ☐ Main memory 48 Mby
- ☐ Disk storage 2 Gby
- ☐ Operating system HP-UX 9.03

Steady state calculation took 2000 second problem time, and 5186 seconds CPU time consumption with a maximum time step size of 0.1 seconds, the ratio of C.P.U. time to real time consequently being 2.59.

Concerning the transient calculation statistics, the maximum time step used throughout the transient calculation was 0.1 seconds, the minimum being 6.25 milliseconds during a 2 seconds period at the transient first stage (figure 43). The 1200 seconds transient calculation required 3405 C.P.U. seconds (figure 44), i.e. a 2.84 overall ratio of C.P.U. time to real time. It must be taken into account that, for the transient calculation, both the model regions downstream pressurizer safety and relief valves and that corresponding to the whole MFW system were removed, thus simplifying the model to a considerable extent. In fact, when first running the transient previously to the MFW section being removed from the model, C.P.U time consumption accounted for 3803.4 seconds (about 10 % higher)

The agreement between calculation results and plant data was acceptable, taking into account the existing uncertainties in the registered plant data described in this report, and Vandellós NPP model for RELAP 5/MOD 3.2 code has shown itself to be adequate for simulation of plant transients, such as the case dealt with in this study. Nevertheless, as it is described below, it is worth pointing out the convenience of evaluating the applicability of a general purpose model to the particular case, in order to modify or remove as needed the non-suitable sections. For simplicity, as well as computing efficiency, it may be even advisable to delete those parts which do not have a significant effect on the specific transient calculation and, on the other hand, may produce any kind of problem. For example, in the calculation described herein, this latter was the reason to remove the pressurizer relief tank section from the model.

The assessment of the code/model set reliability and goodness has resulted limited to a certain extent because of lack of some significant plant records, which made necessary to impose estimated combined evolutions of the associated parameters as boundary conditions to reproduce the overall plant performance.

A significant feature dealing with the void fraction distribution in the boiler cells which affected the steam generator secondary mass distribution was observed during the steady state calculation. The void fraction increased from volume to volume up to the boiler region (7-cell pipe 200) fifth cell, where it dropped below that of the fourth cell, increasing again when ascending across the remaining upper cells. It was observed that the code predicted a slug flow regime in the first five cells and then an annular-mist flow in the upper ones. Consequently, it is thought that the described anomalous result had to do with the flow regime transition. It could be produced by the different interphase frictions between both regimes, which would lead to less liquid being carried over in the upper cells towards the separator volume. It is worth to point out that, when investigating this circumstance, the same code behaviour was also observed in the typical PWR model provided with the code as a sample problem (typpwr.i). Other sources consulted in this regard also referenced this matter but did not provide suitable solutions.

Note.- some minor errors were detected in the code associated documentation, namely in the Volume II of the code manual (User's Guide and Input Requirements) :

- At the end of the Hydrodynamic Components describing cards section (item A7.11.6 : Accumulator Tank Initial Fill Conditions, Standpipe/Surgeline Length/Elevation and Tank Wall Heat Transfer Terms), there are several non-corresponding paragraphs (from "The volume flags entered in W8 ..." to the end of the section)

- In the Reactor Kinetics section, items A12.8.6 (Cards 30001701 through 30001799, Volume Weighting Factors) and A12.8.7 (Cards 30001801 through 30001899, Heat Structure or SCDAP Component Weighting Factors), cards are described that should be used if the TABLE3 or TABLE4 options are selected, and not otherwise, as it is read.

VAPOR A TURBINA AGUA AL REACTOR AUXILIAR

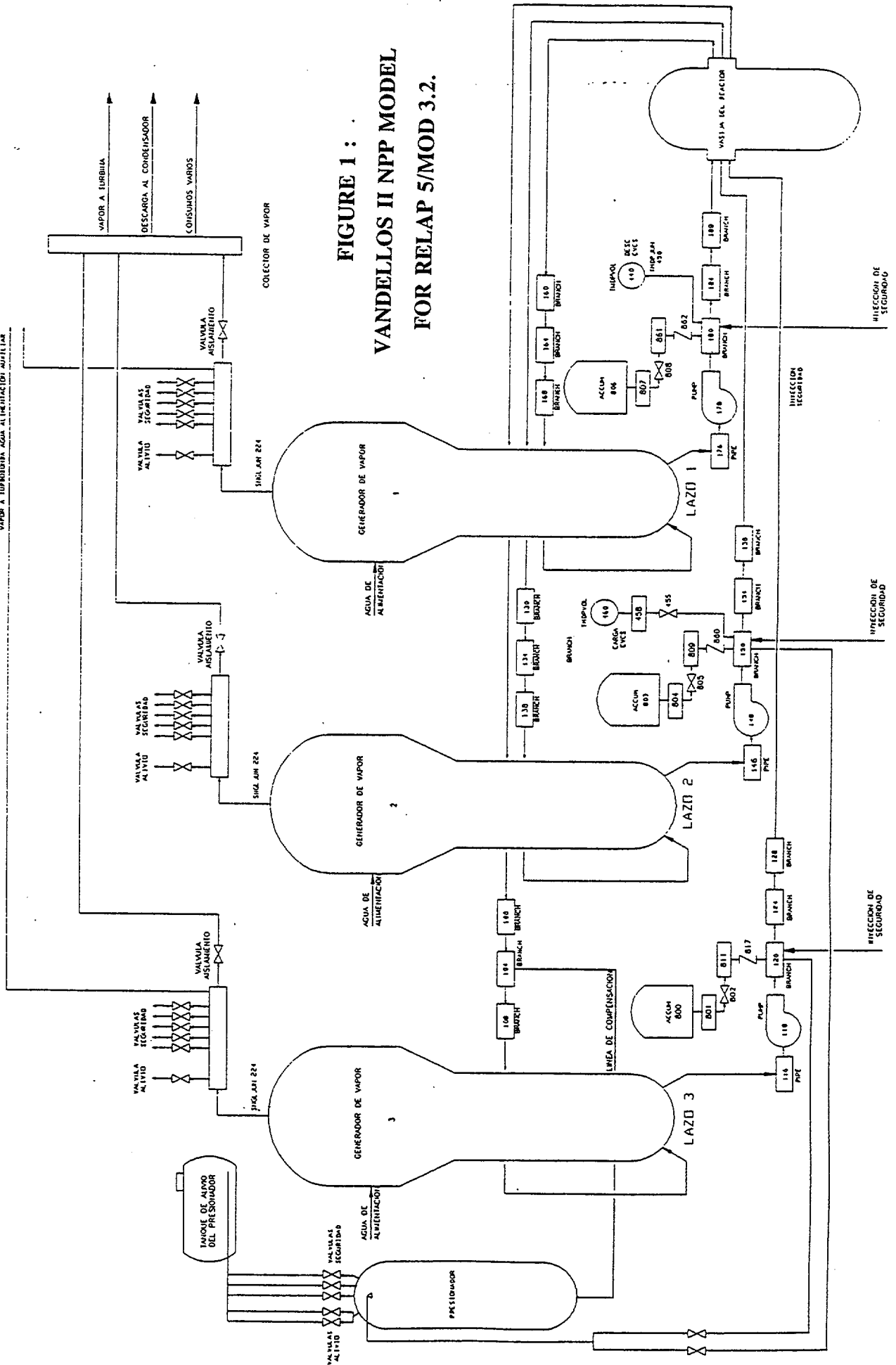

FIGURE 1 :
VANDELLOS II NPP MODEL
FOR RELAP 5/MOD 3.2.

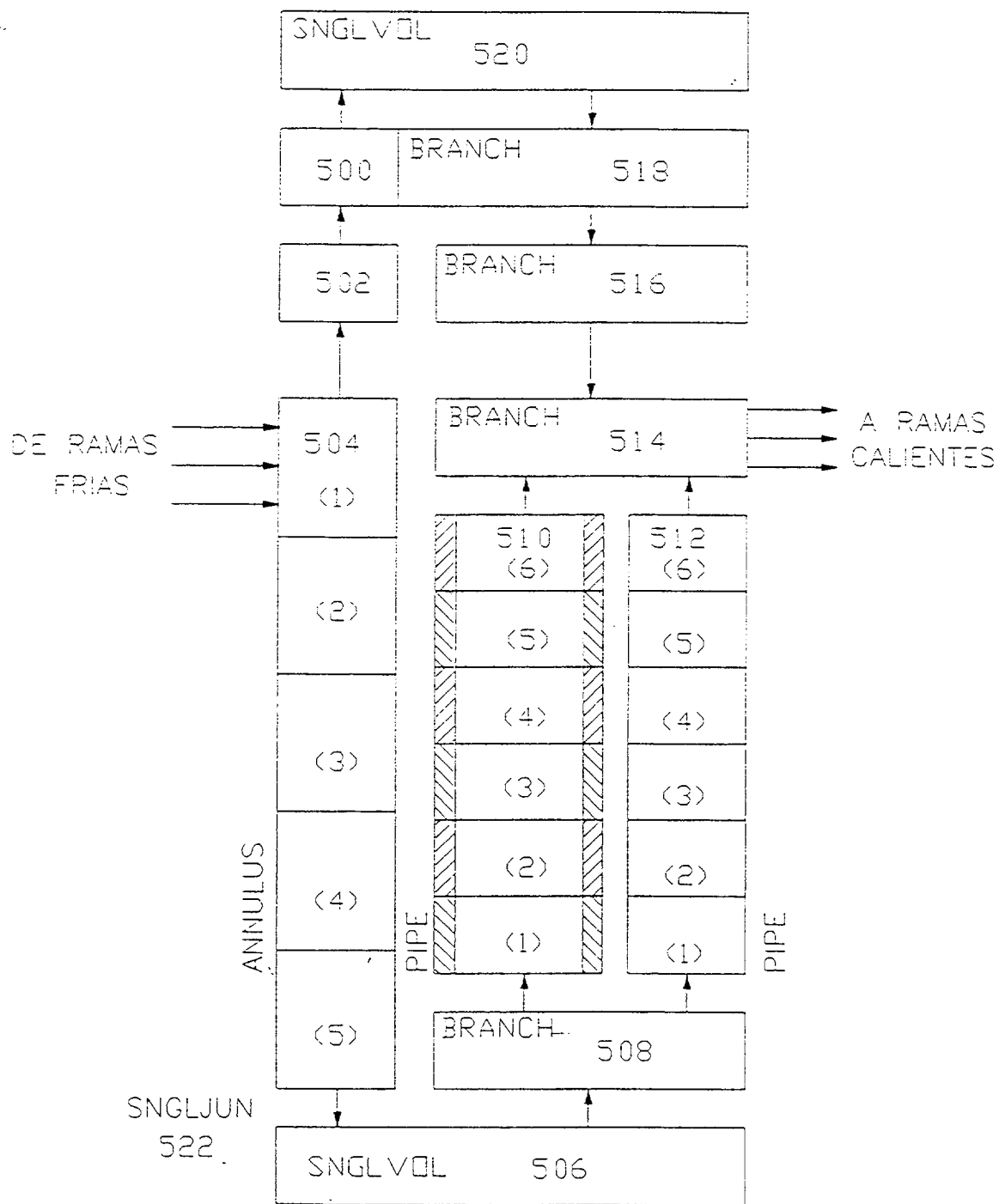

FIGURE 2 : REACTOR PRESSURE VESSEL NODALIZATION

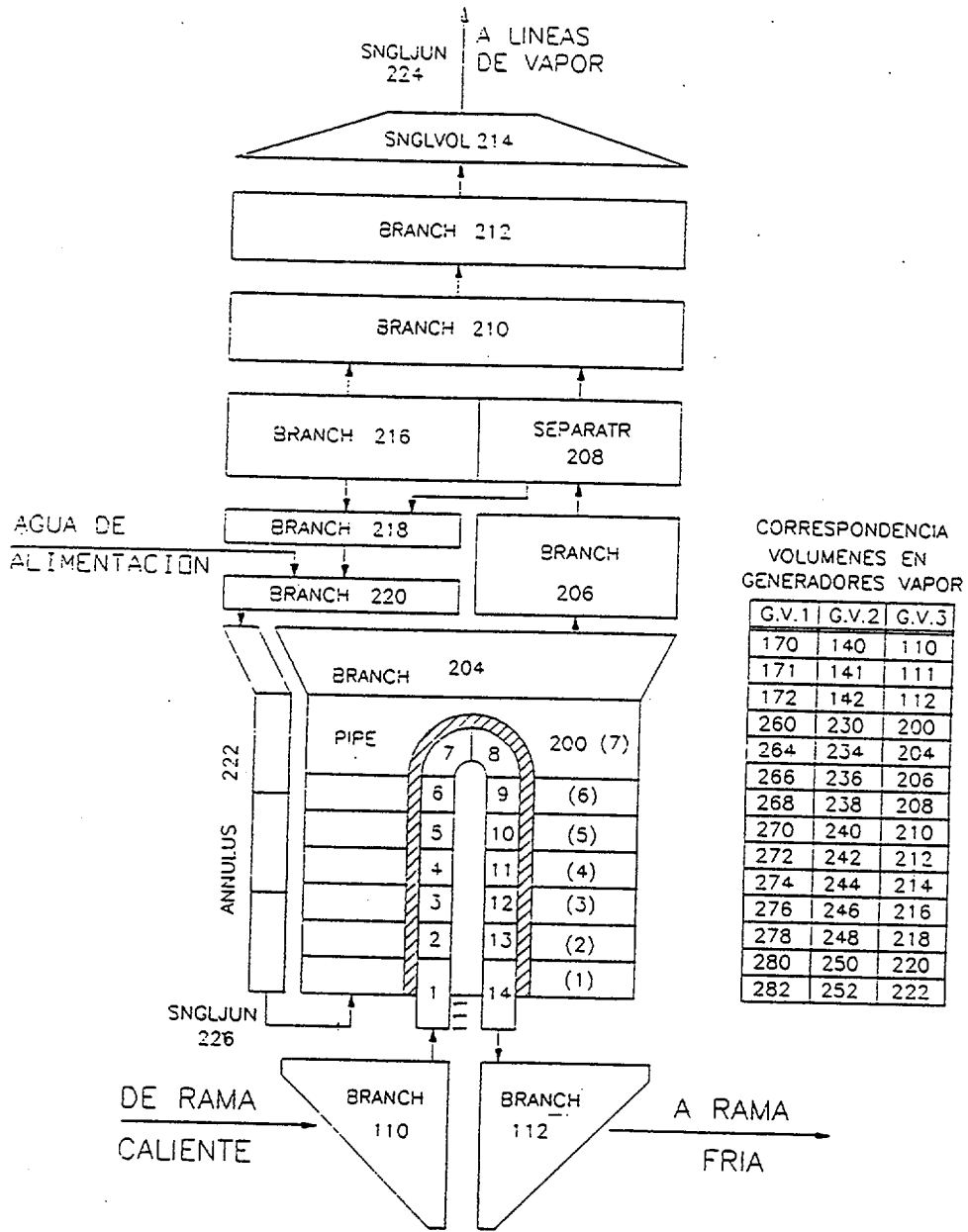

FIGURE 3 : STEAM GENERATOR NODALIZATION

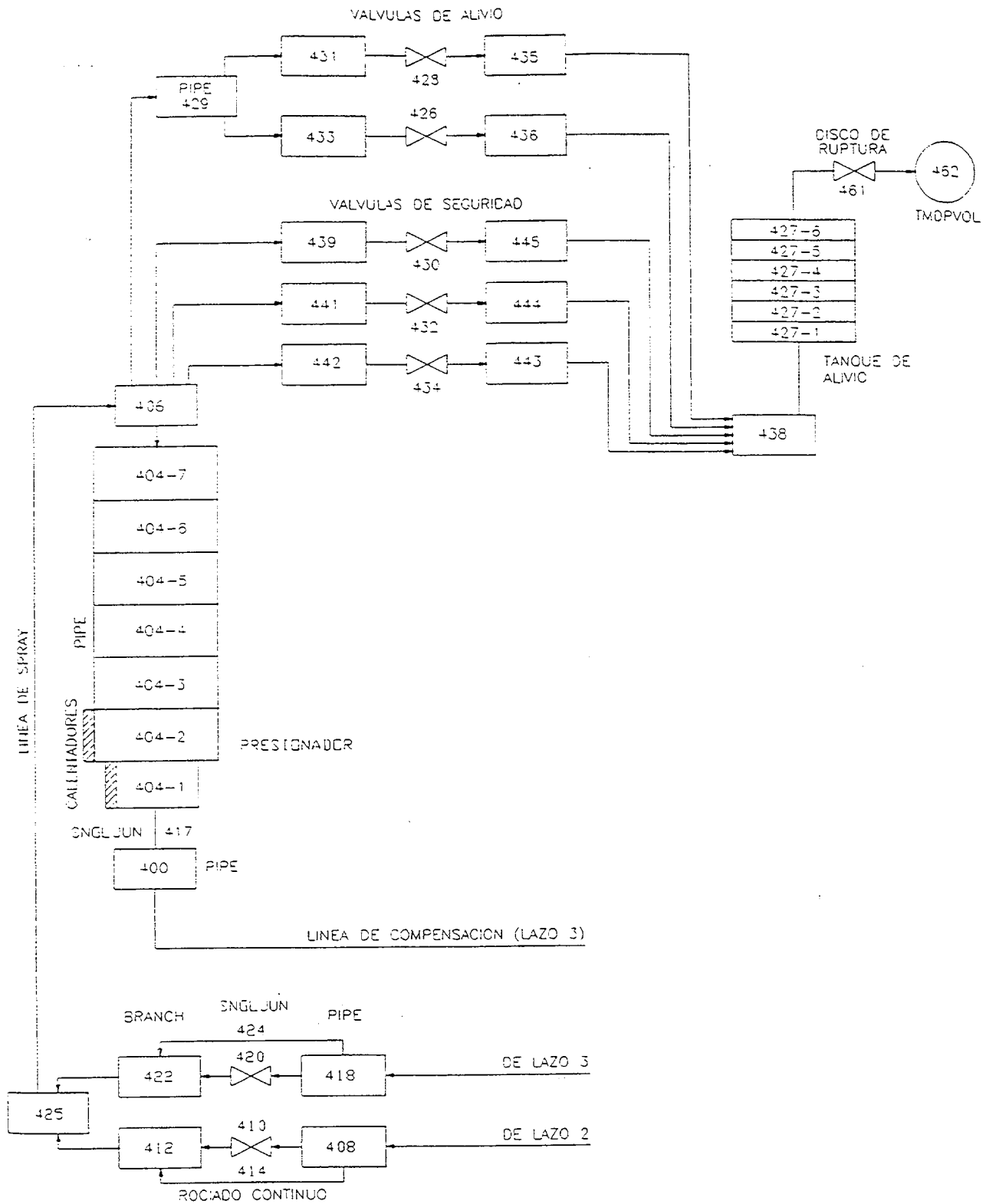

FIGURE 4 :
PRESSURIZER AND ASSOCIATED PIPING
AND VALVES NODALIZATION

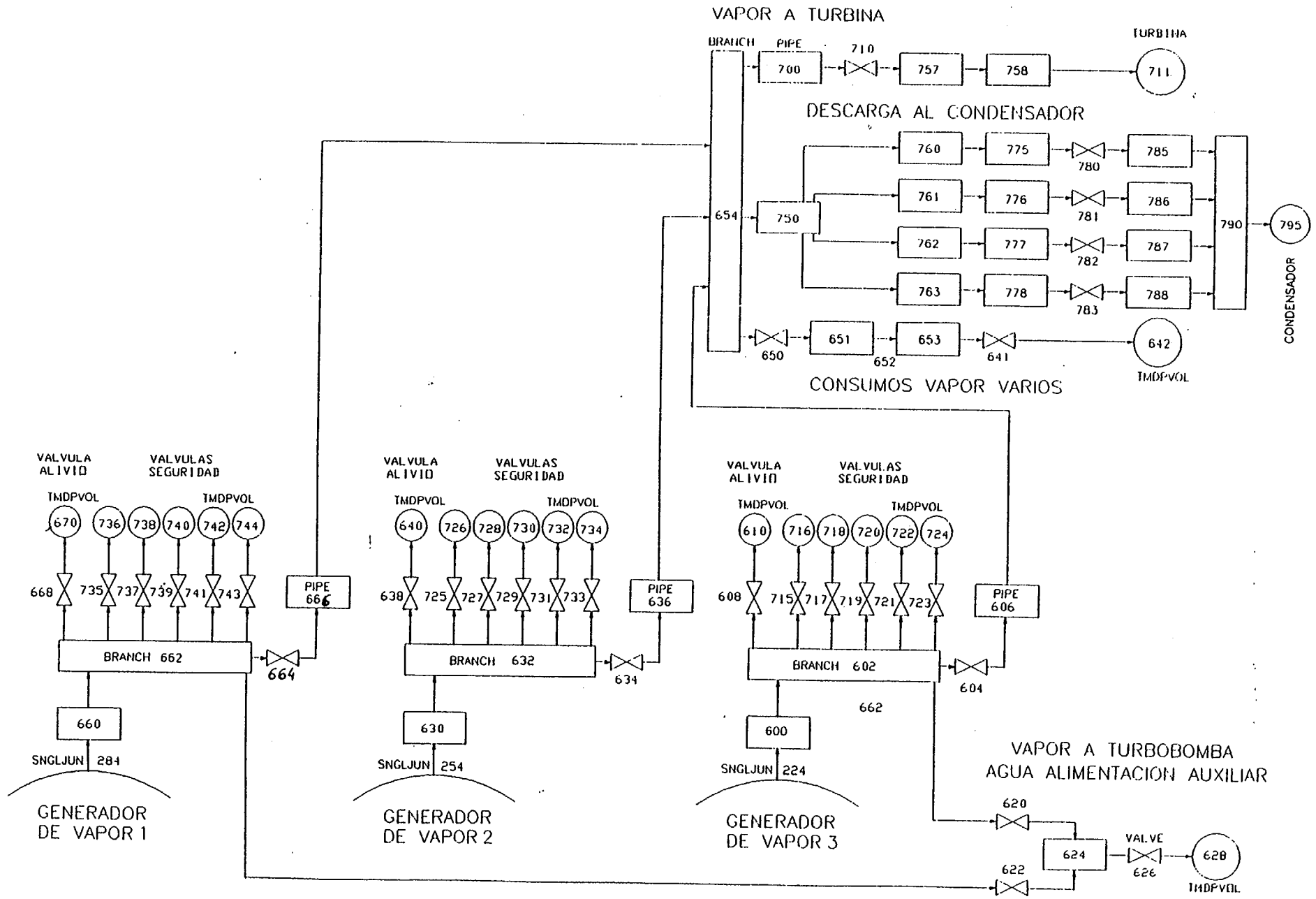

FIGURE 5 : STEAM LINES NODALIZATION

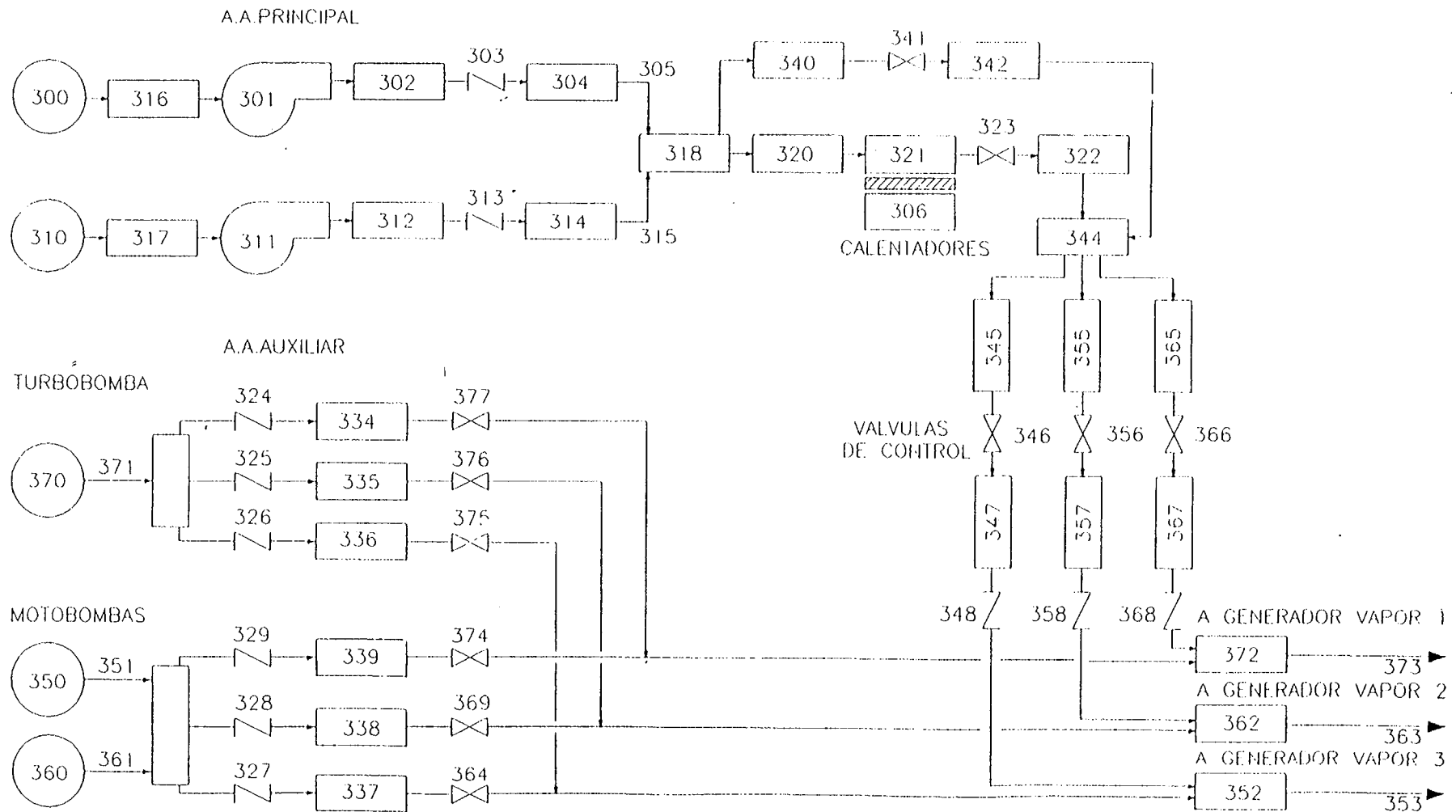

FIGURE 6 : MAIN FEEDWATER AND AUXILIARY FEEDWATER SYSTEMS NODALIZATION

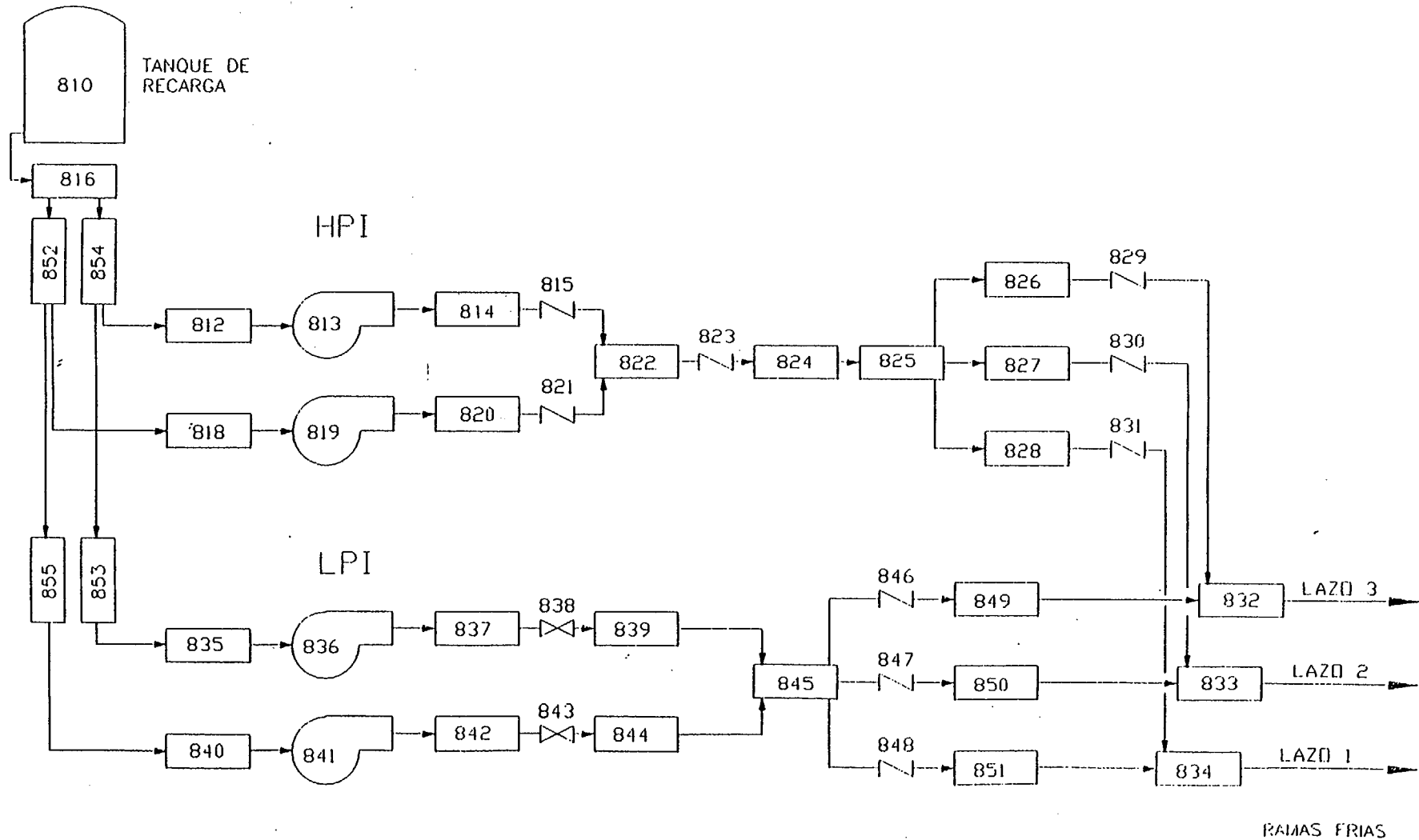
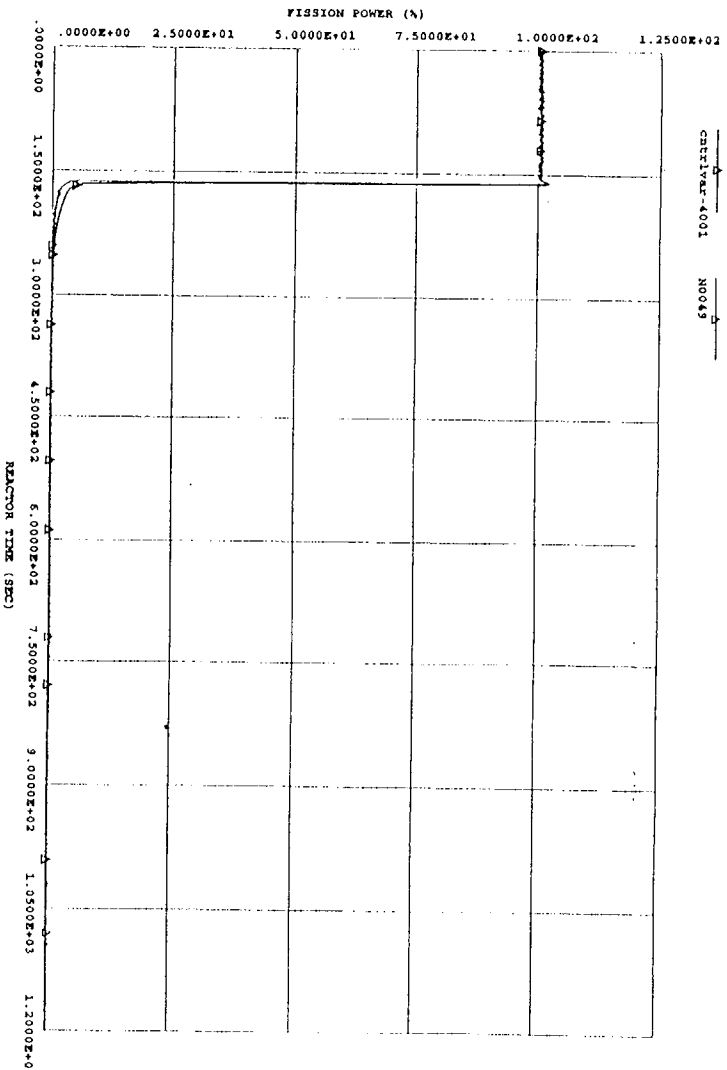

FIGURE 7 : EMERGENCY CORE COOLING SYSTEMS NODALIZATION

NSI's INDUMENTARY MANUAL CLOSURE (26-6-89)

Fission power (%) (RELAJ/PLANT)

FIGURA 9



Channel-4001 NO049

NSI's INDUMENTARY MANUAL CLOSURE (26-6-89)

Pressurizer pressure (Kg/cm2) (RELAJ/PLANT)

FIGURA 10

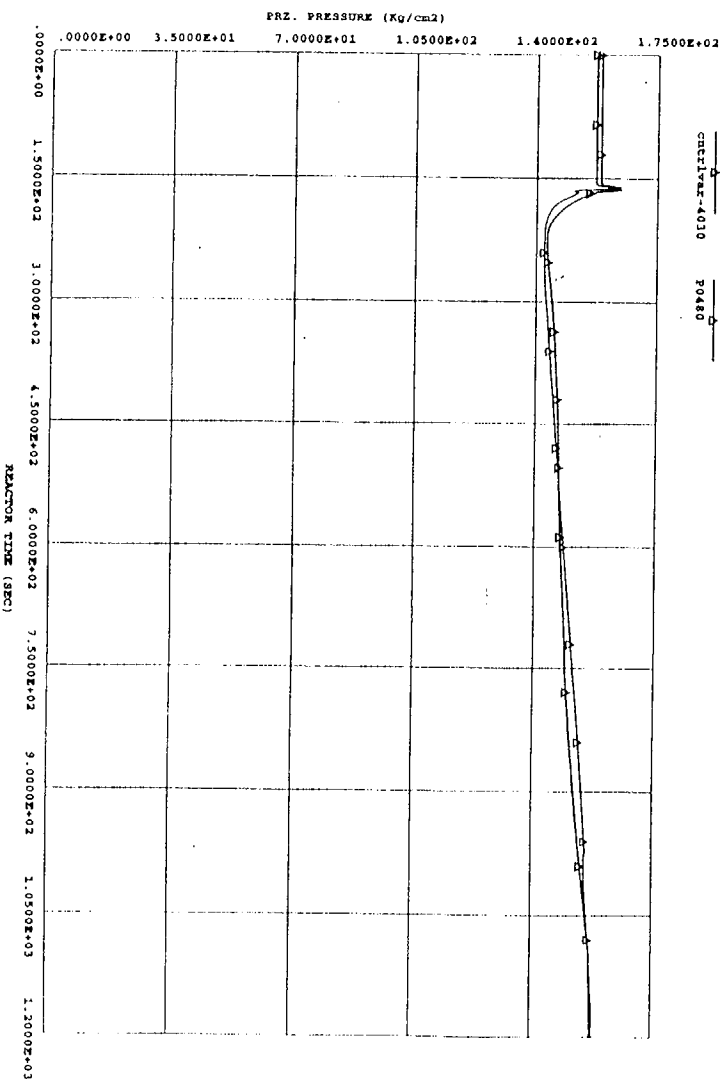

Channel-4010 P0480

FIGURE 11

NSIVS INDUWMENT MANUAL CLOSURE (26-6-89)

Pressureizer collapsed level (%) (REMAP/PLANT)

channel-146 10480

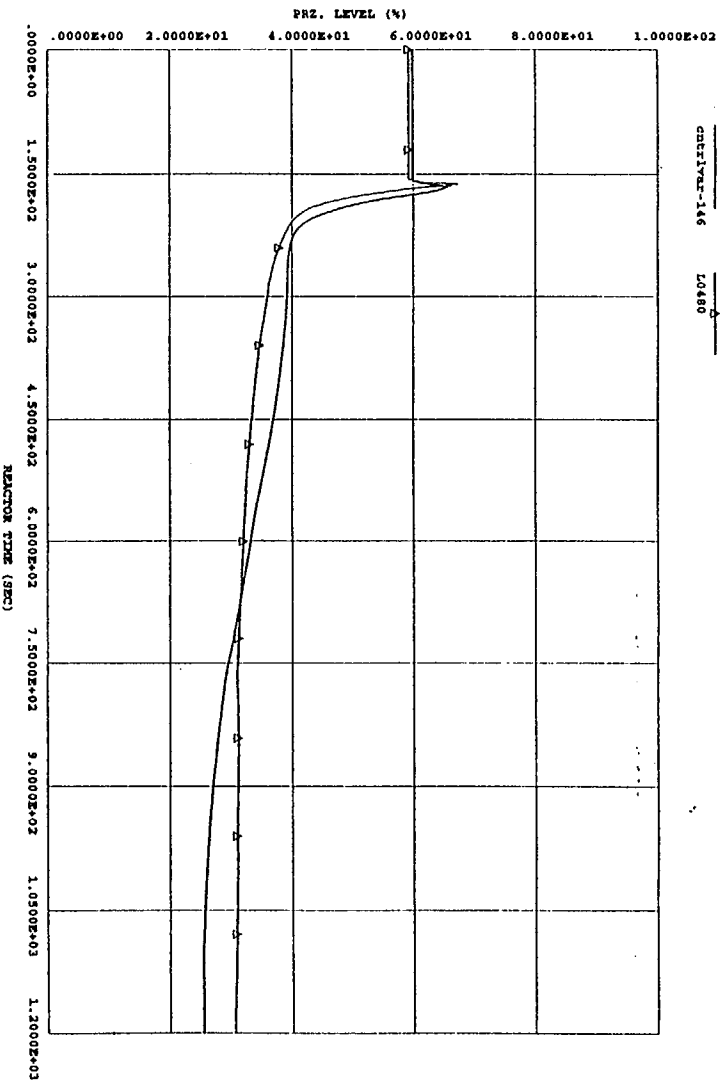
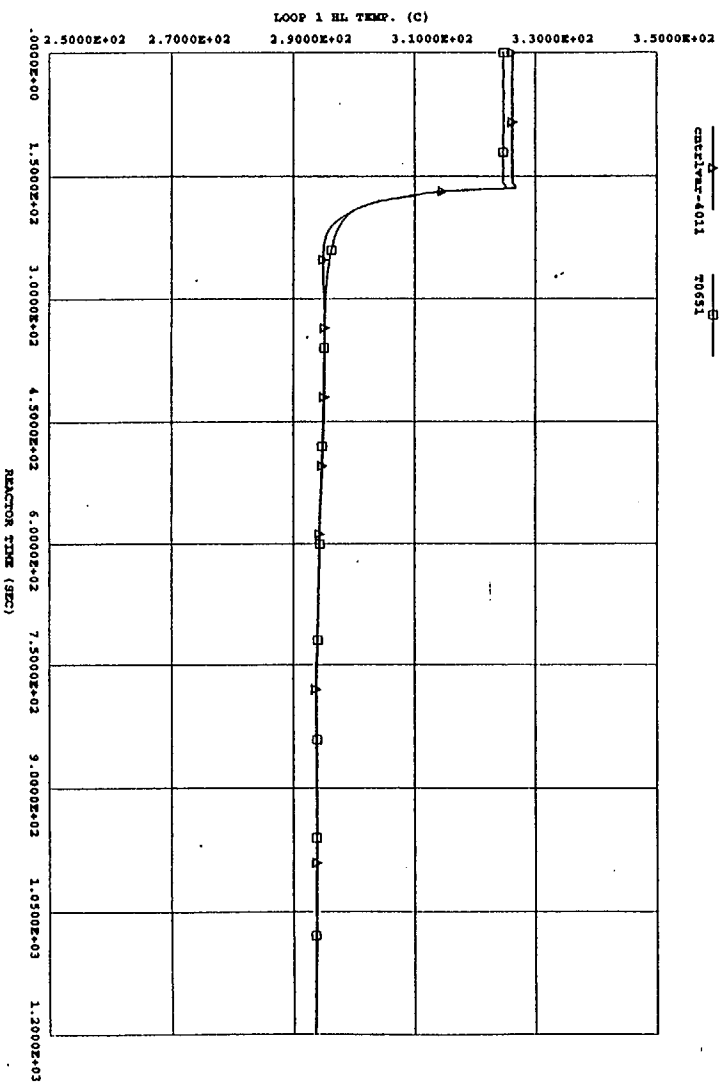

FIGURE 12

NSIVS INDUWMENT MANUAL CLOSURE (26-6-89)

Loop 1 hot leg temperature (C) (REMAP/PLANT)

channel-4011 70631



NET'S INADVERTENT MANUAL CLOSURE (26-6-89)

Loop 2 hot leg temperature (C) (RELAY/PLANT)

FIGURE 13

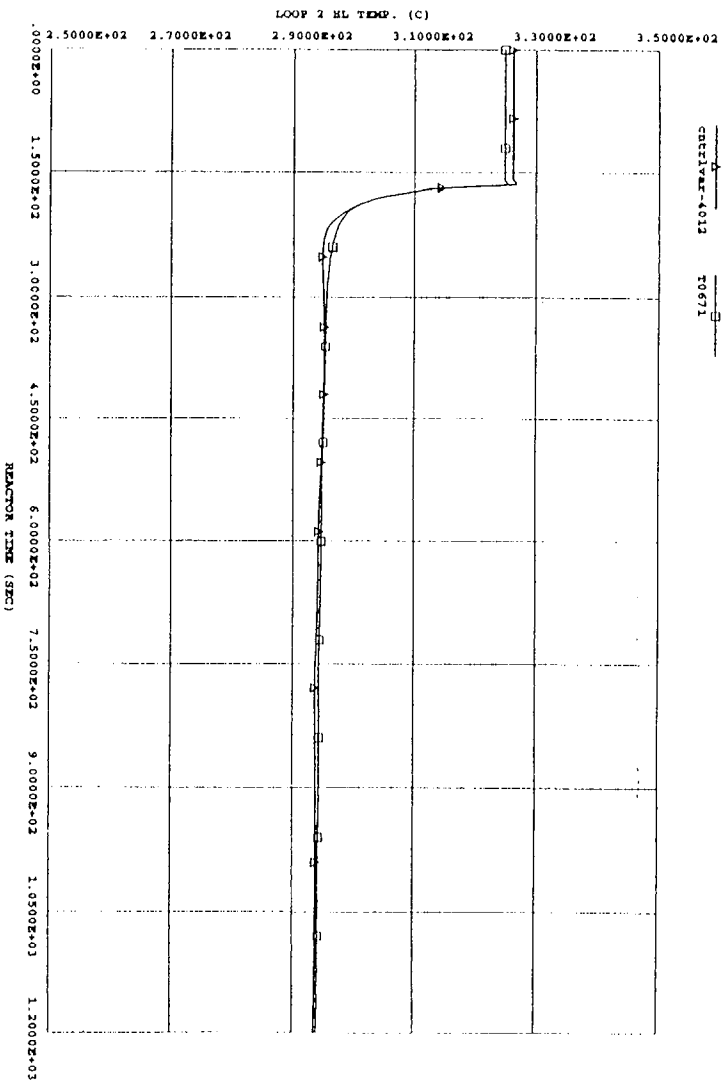

NET'S INADVERTENT MANUAL CLOSURE (26-6-89)

Loop 3 hot leg temperature (C) (RELAY/PLANT)

FIGURE 14

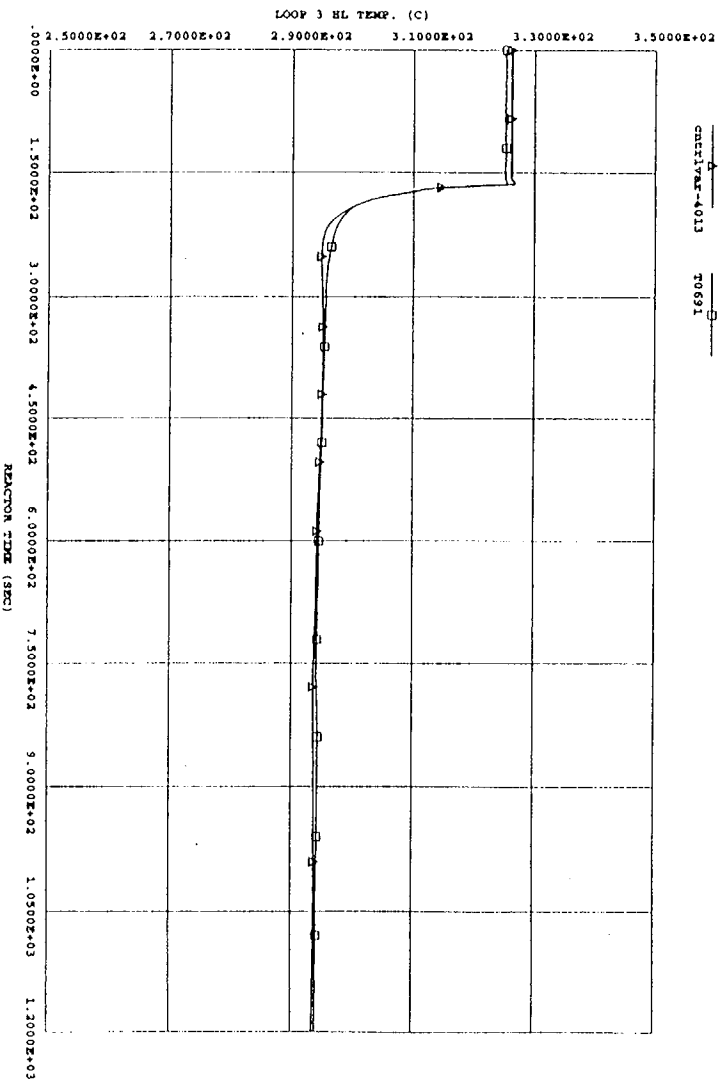

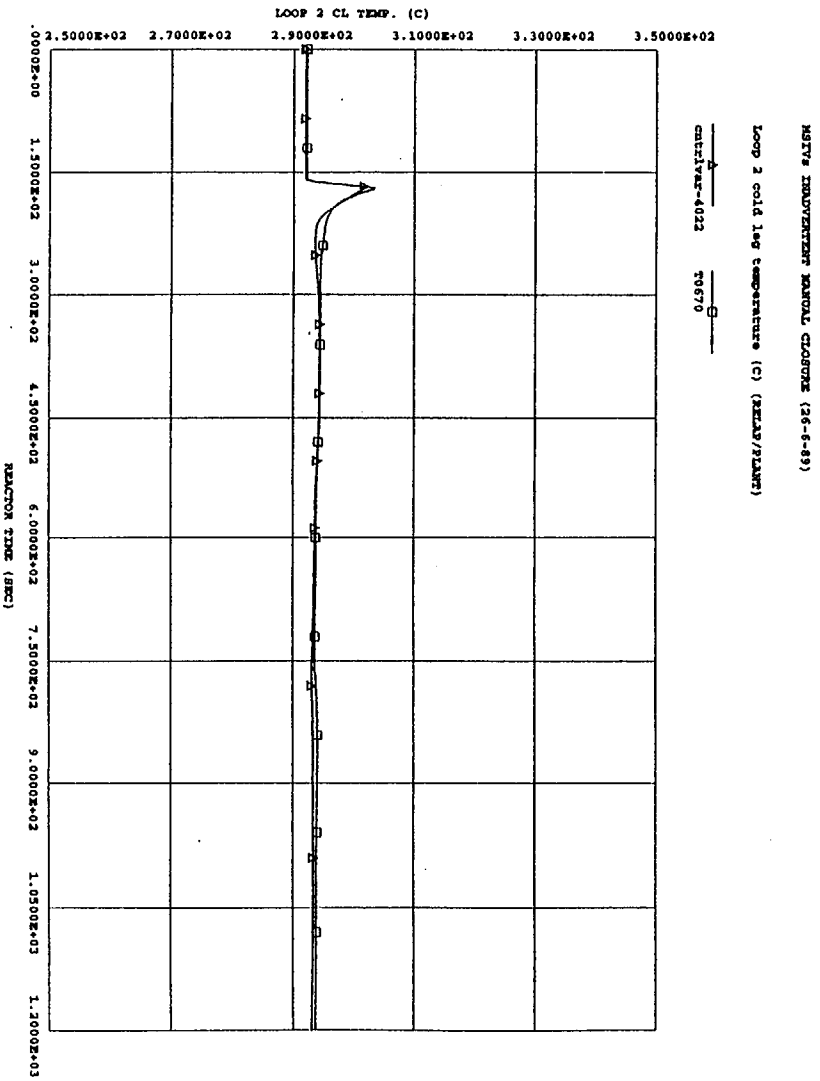
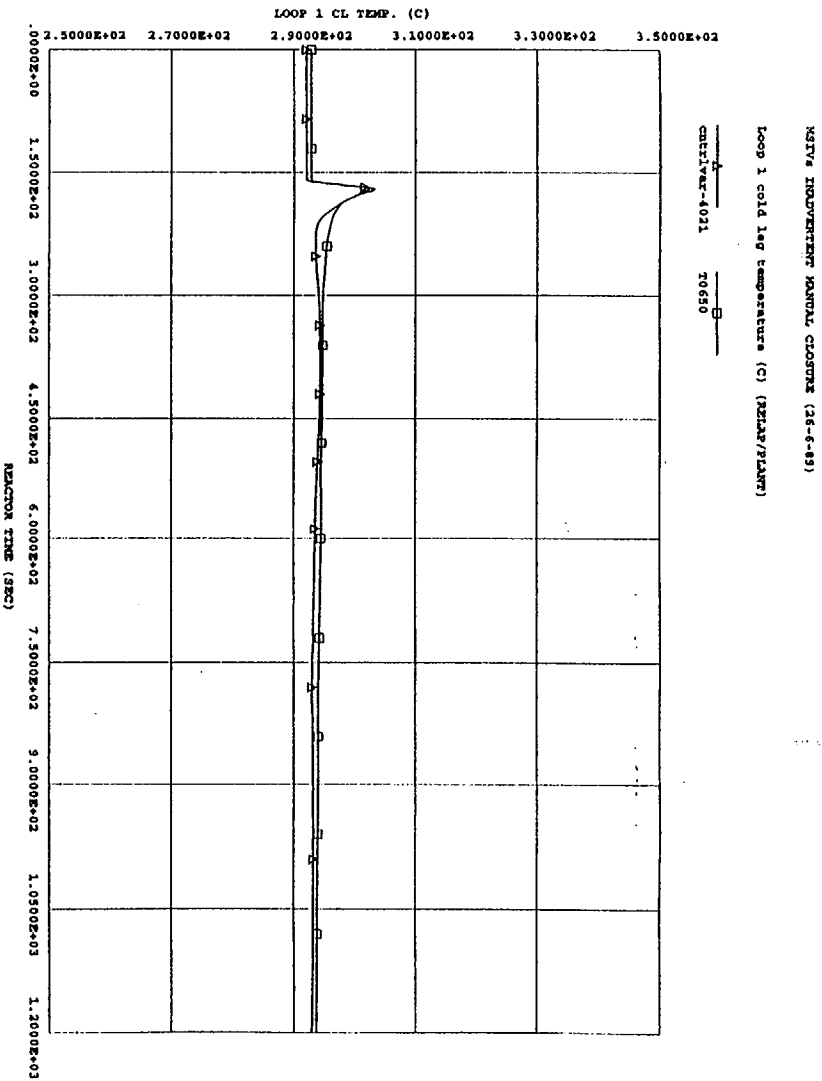

NETIV# INDEPENDENT MANUAL CLOSURE (26-6-89)

Loop 3 cold leg temperature (C) (RELA5/PIANT)

FIGURE 17

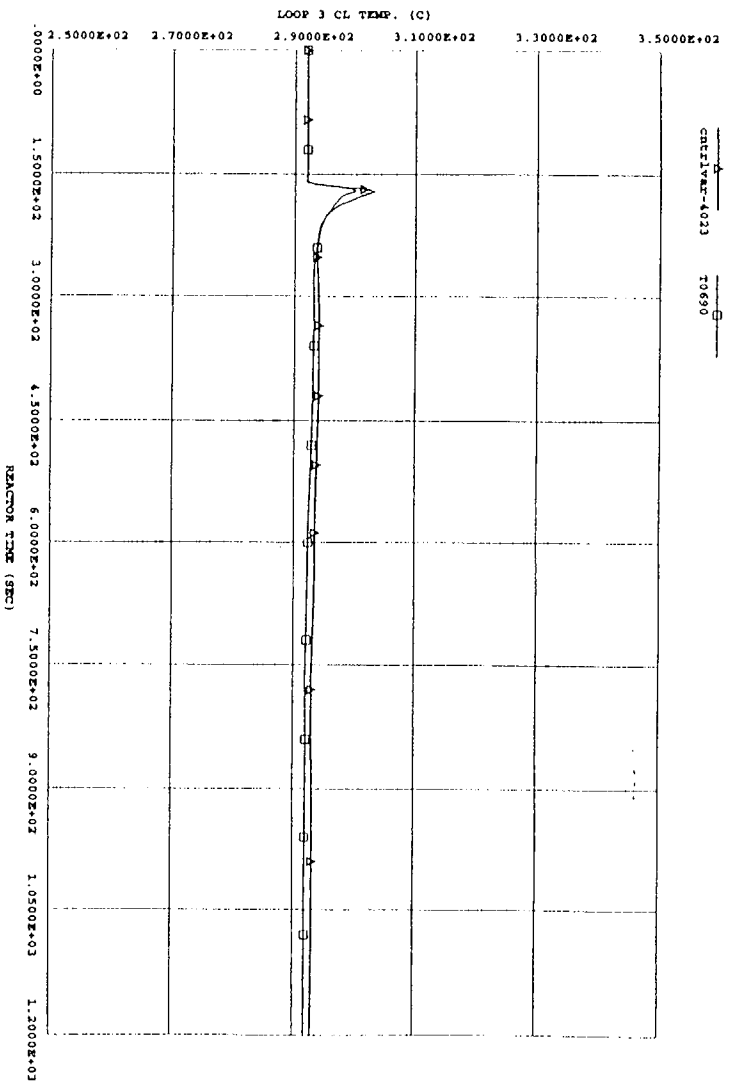

NETIV# INDEPENDENT MANUAL CLOSURE (26-6-89)

Loop 1 average temperature (C) (RELA5/PIANT)

FIGURE 18

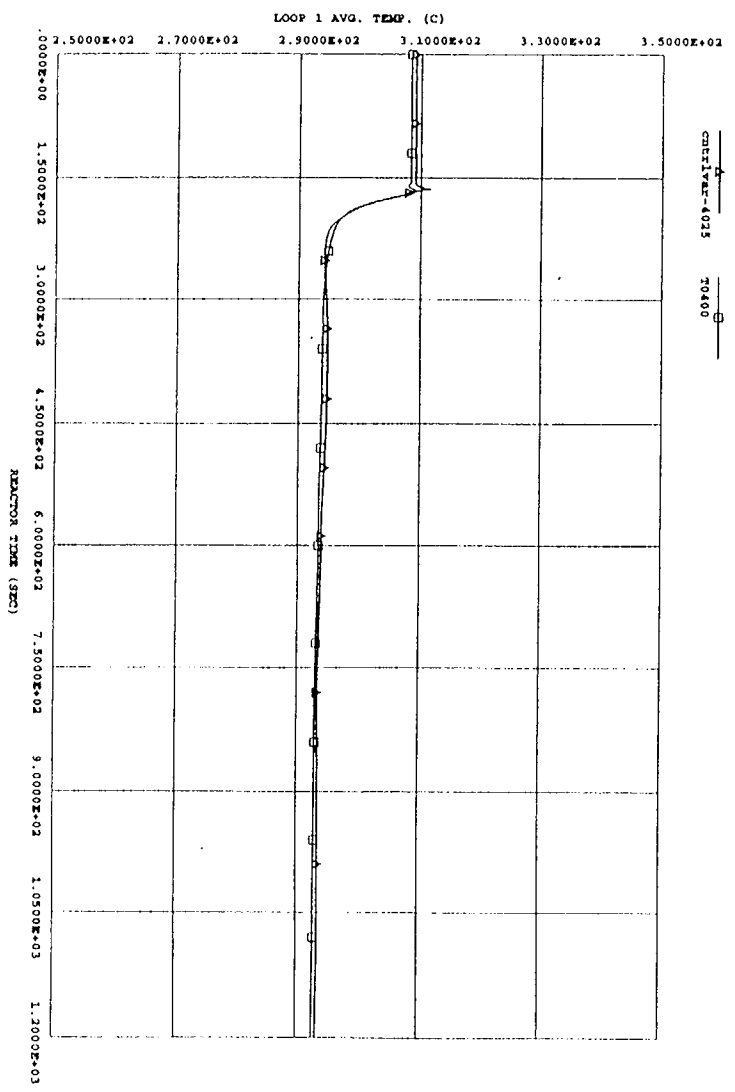

NAIYA INDUVENTENT MANUAL CLOSURE (26-6-89)
 Loop 2 average temperature (C) (RELAY/PLANT)

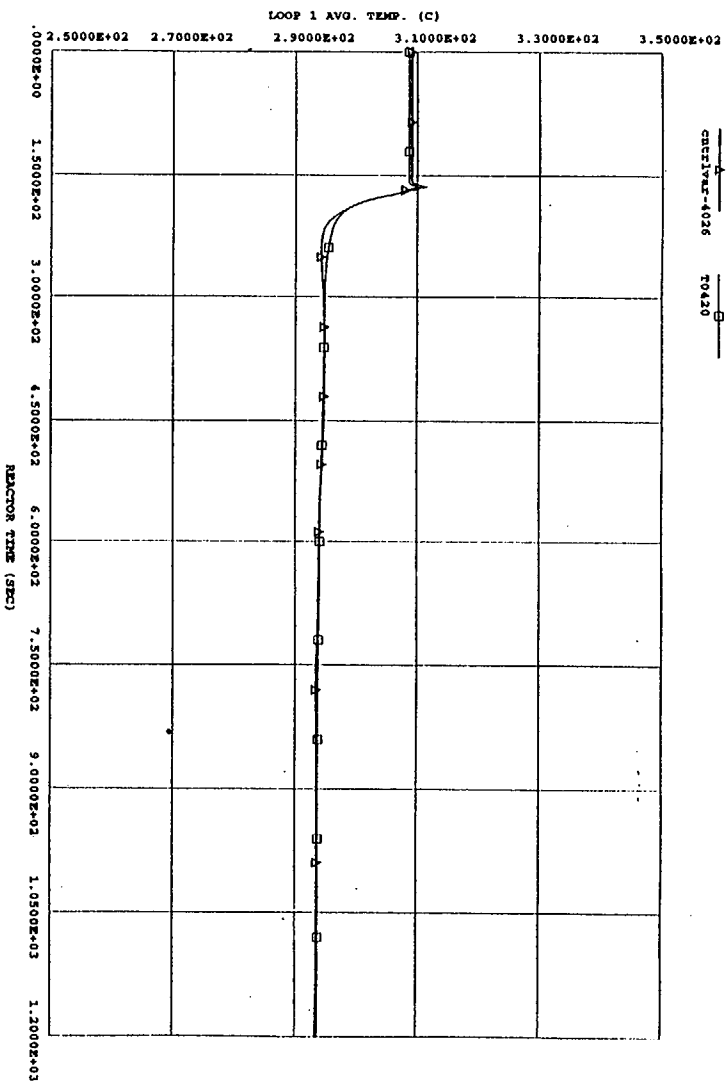

CRITICAL-4026 T0420

NAIYA INDUVENTENT MANUAL CLOSURE (26-6-89)
 Loop 3 average temperature (C) (RELAY/PLANT)

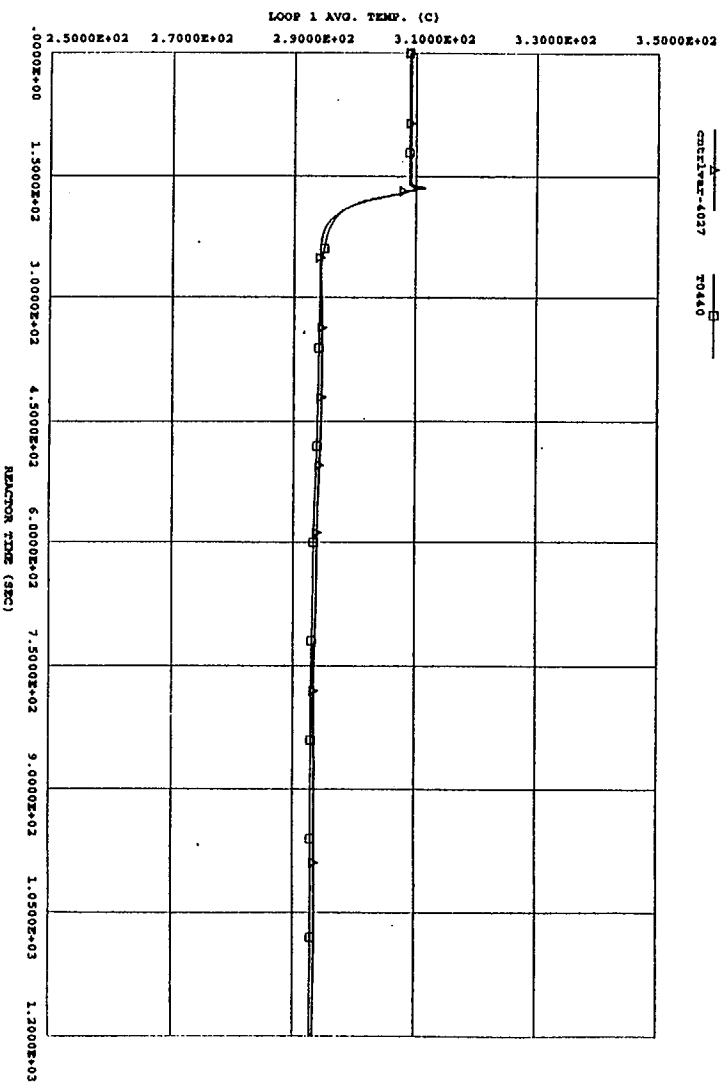

CRITICAL-4027 T0440

MSIVs INADVERTENT MANUAL CLOSURE (26-6-89)

Figura 21

RCS loops 1,2,3 delta-temperature (C)

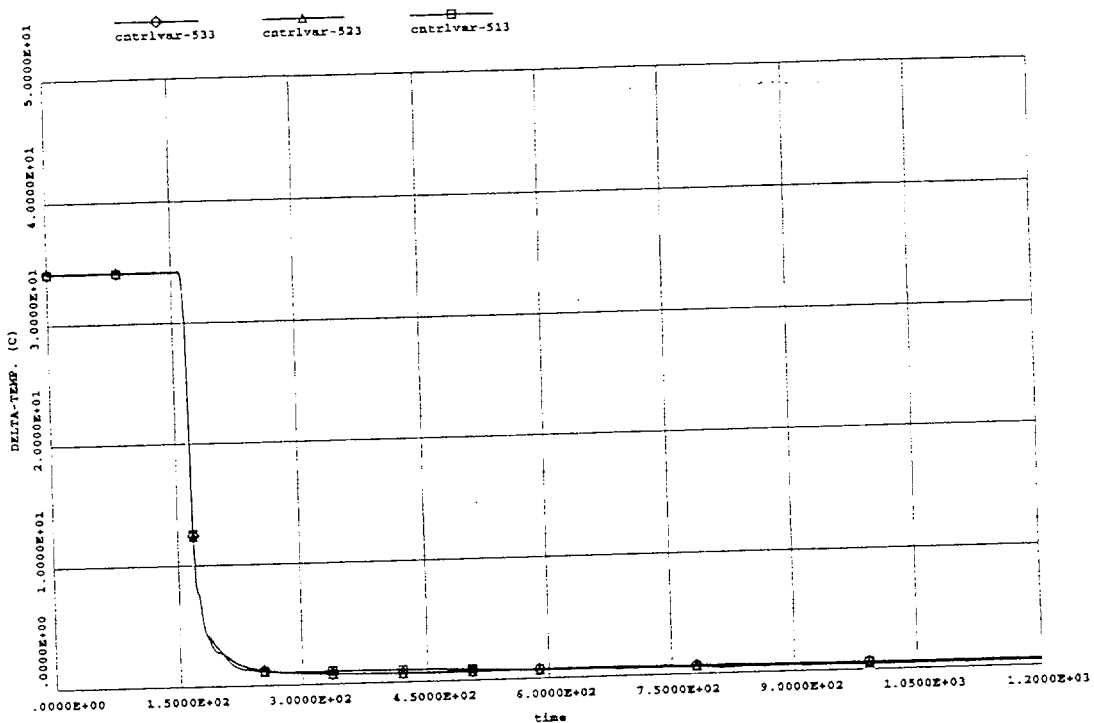

MSIVs INADVERTENT MANUAL CLOSURE (26-6-89)

Figura 22

RCS loop 1 mass flow rate (%) (RELAP/PLANT)



Figura 23



Figura 24

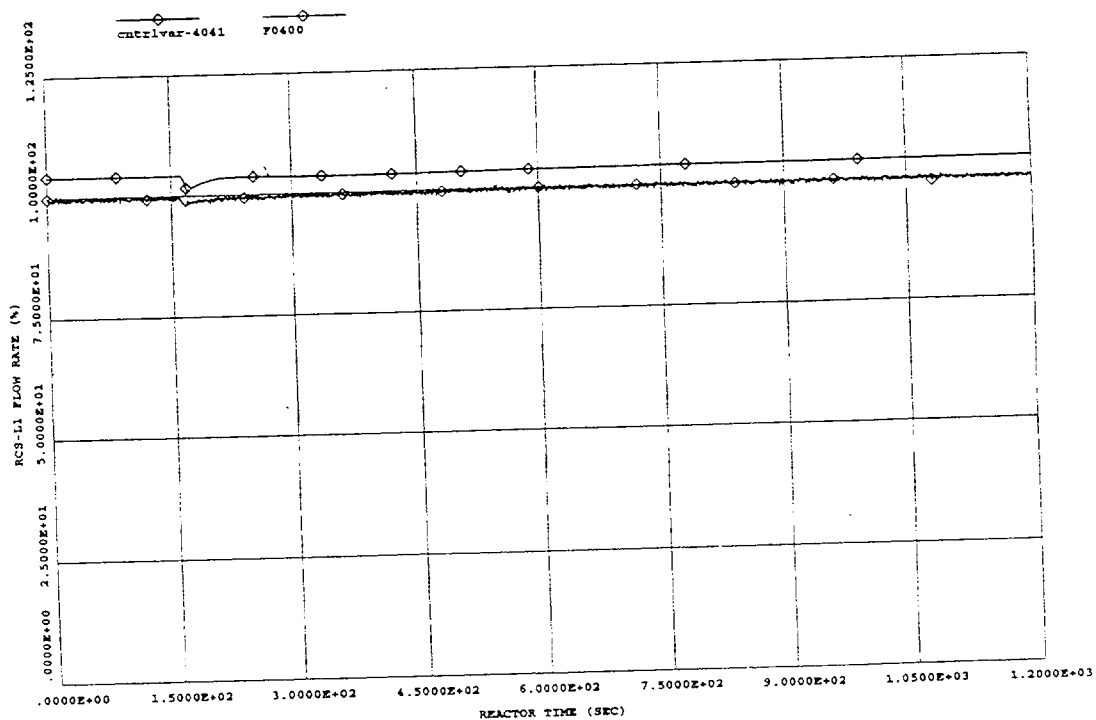

Figura 25

MSIV: INADVERTENT MANUAL CLOSURE (26-6-89)

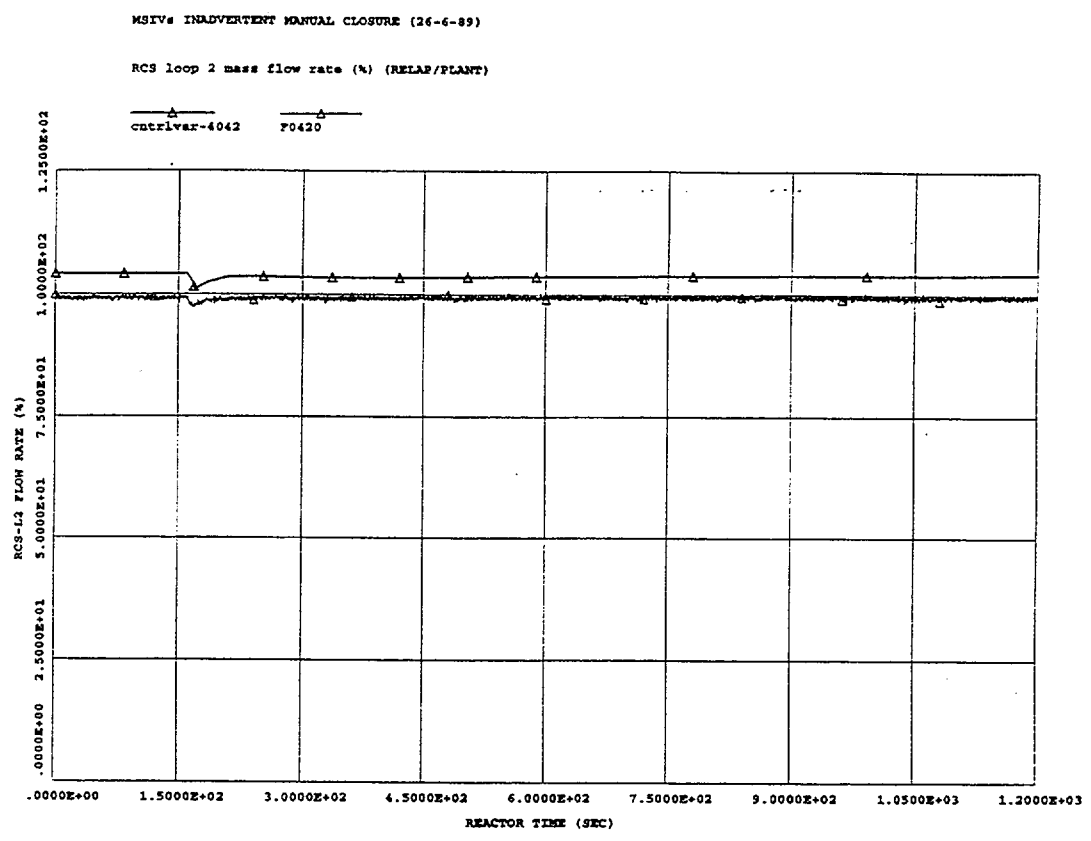
SG-1 pressure (Kg/cm2) (RELAP/PLANT)

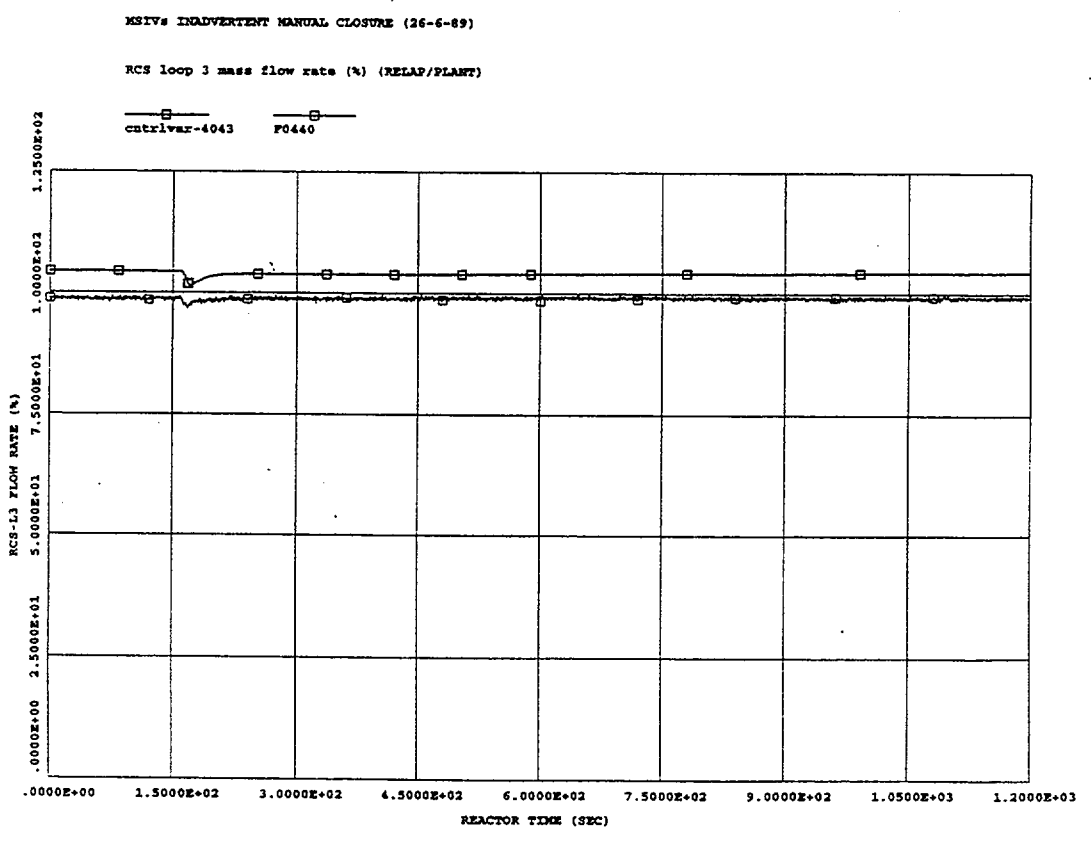

Figura 26

MSIV: INADVERTENT MANUAL CLOSURE (26-6-89)

SG-2 pressure (Kg/cm2) (RELAP/PLANT)

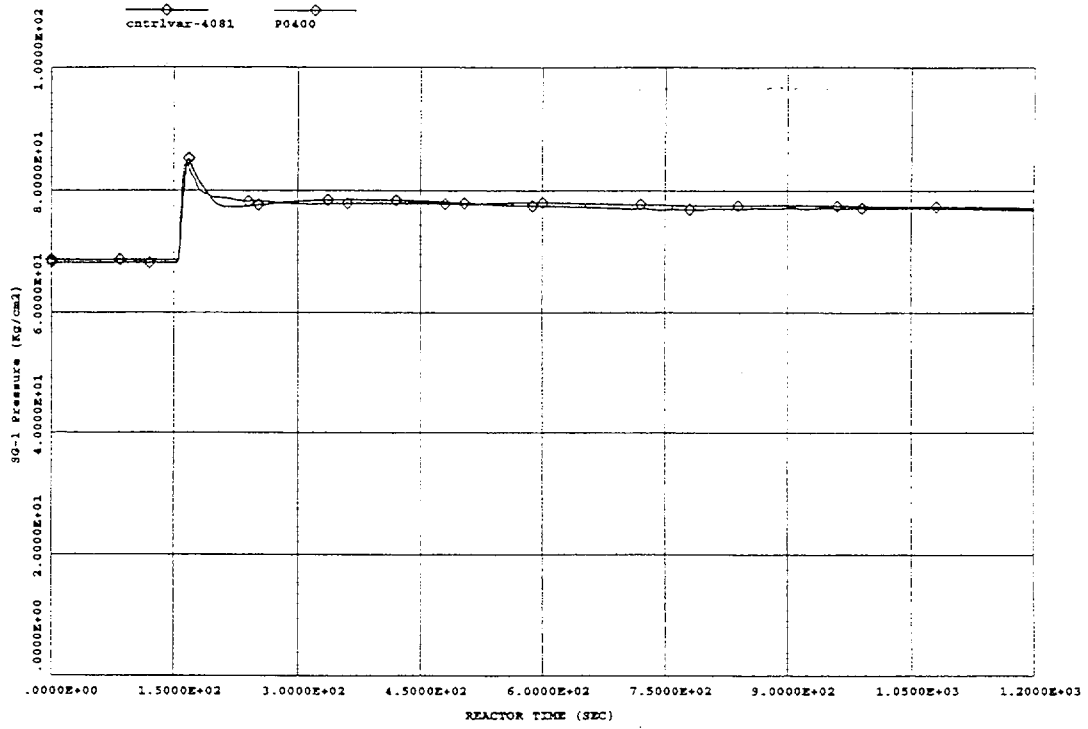
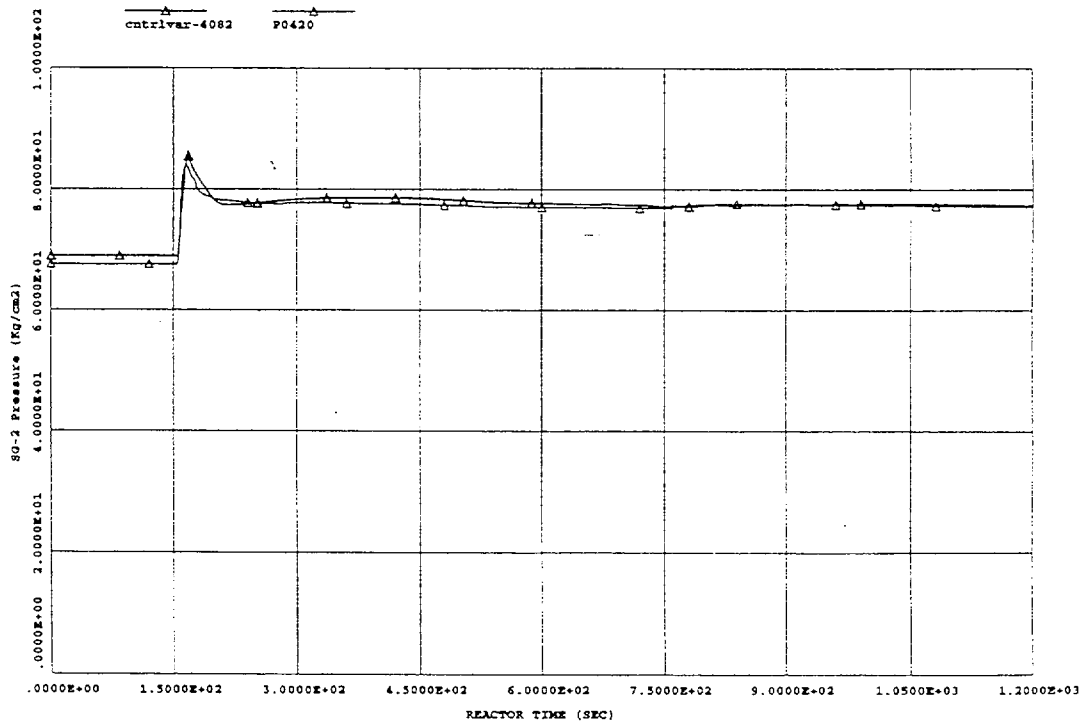

MSIVs INADVERTENT MANUAL CLOSURE (26-6-89)

Figura 27

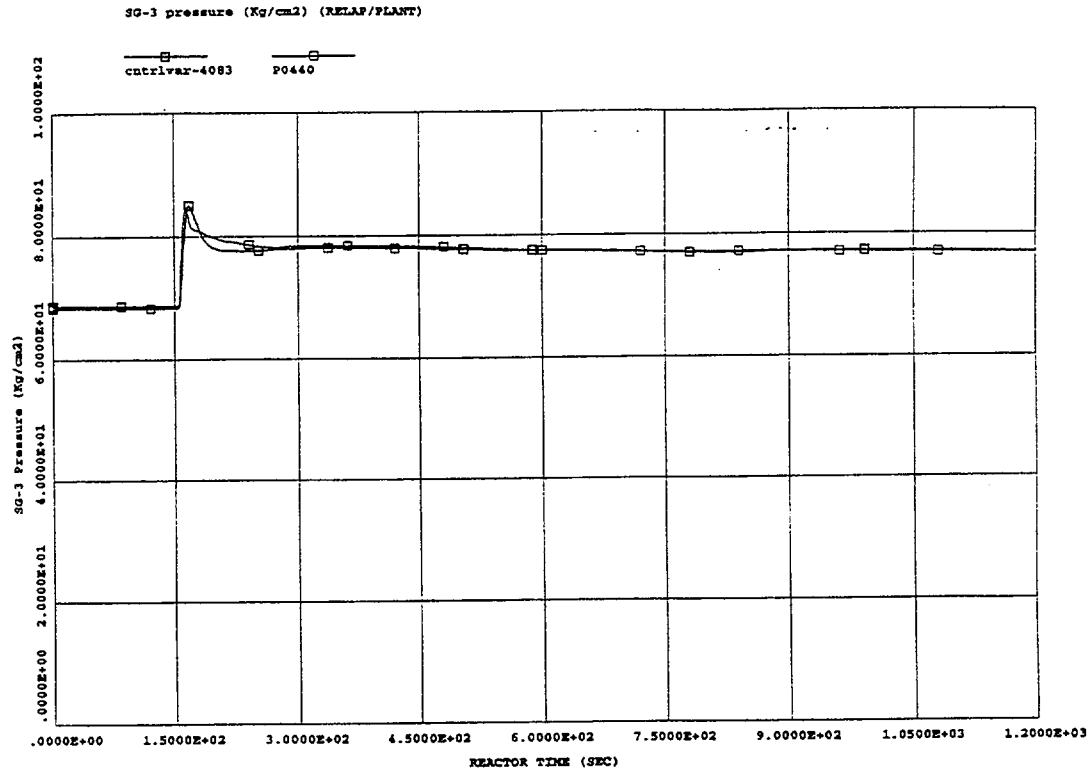

MSIVs INADVERTENT MANUAL CLOSURE (26-6-89)

Figura 28



Figura 29

MSIVs INADVERTENT MANUAL CLOSURE: (26-6-89)

SG-2 NR Level (%) (RELAP/PLANT)

cnr1var-234 L0420

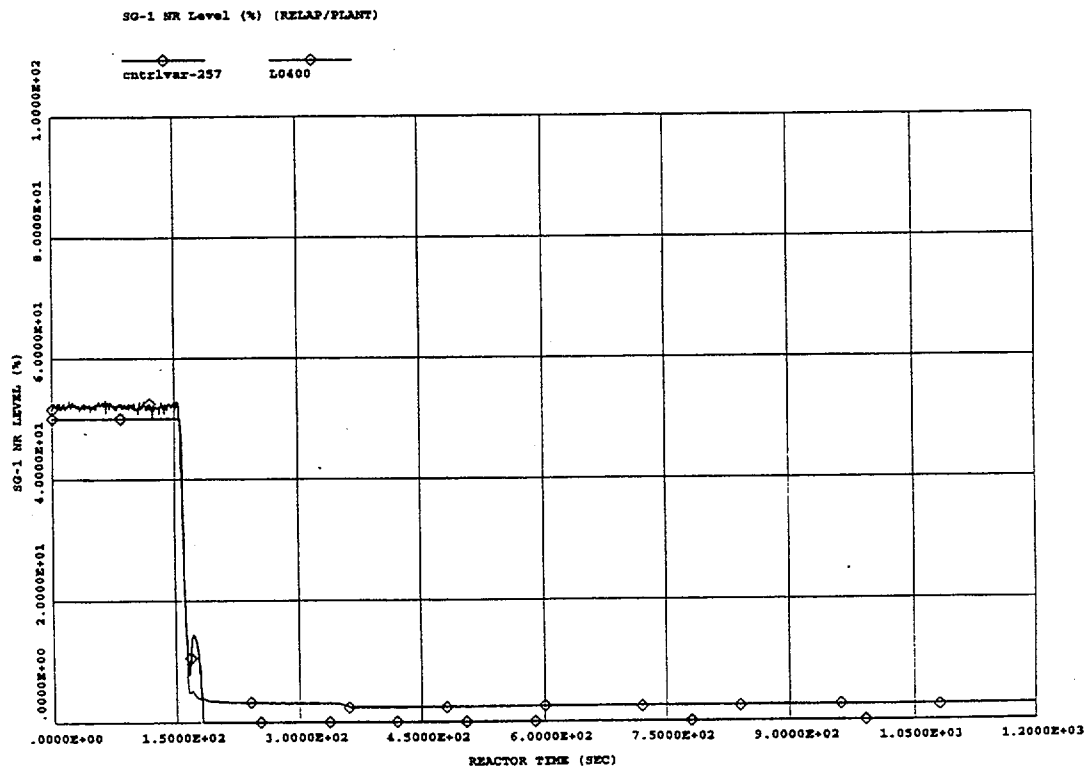

Figura 30

MSIVs INADVERTENT MANUAL CLOSURE (26-6-89)

SG-3 NR Level (%) (RELAP/PLANT)

cnr1var-210 L0440

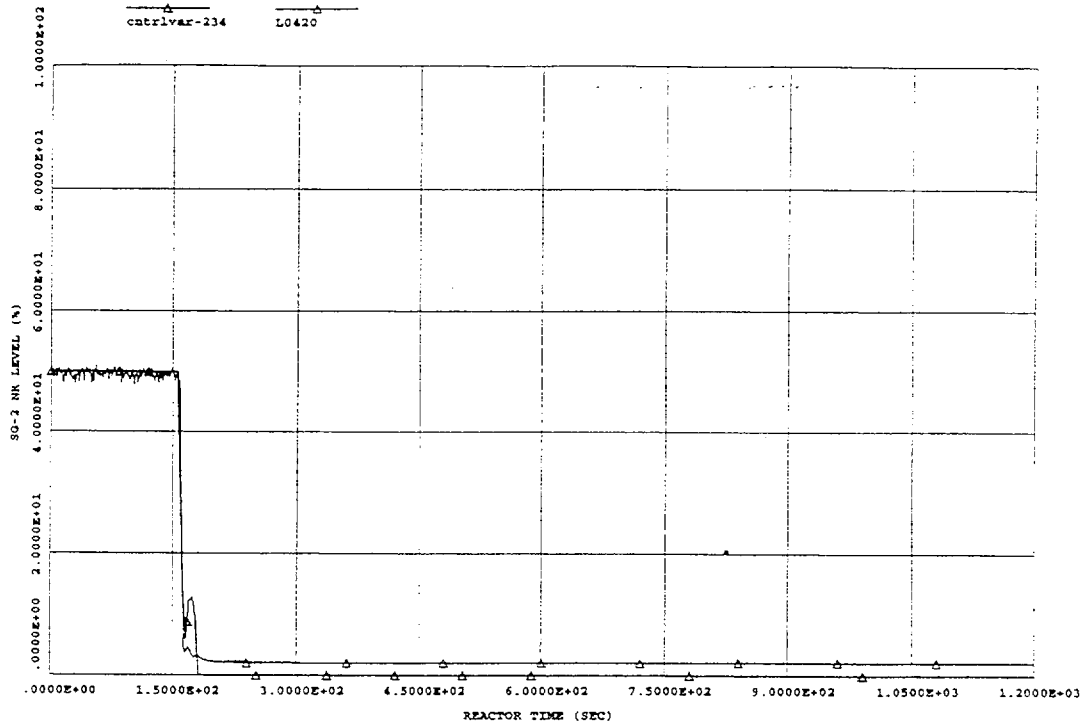
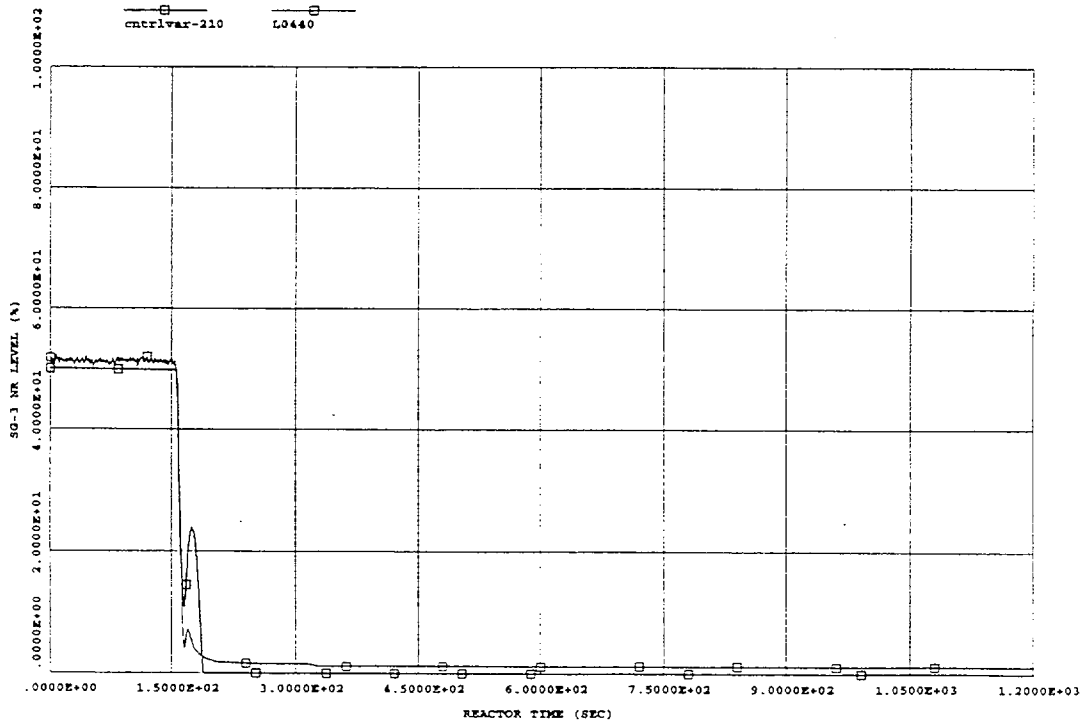

MSIVs INADVERTENT MANUAL CLOSURE (26-6-89)

S.G. 1 steam flow (Tm/h) (RELAP/PLANT)

Figura 31

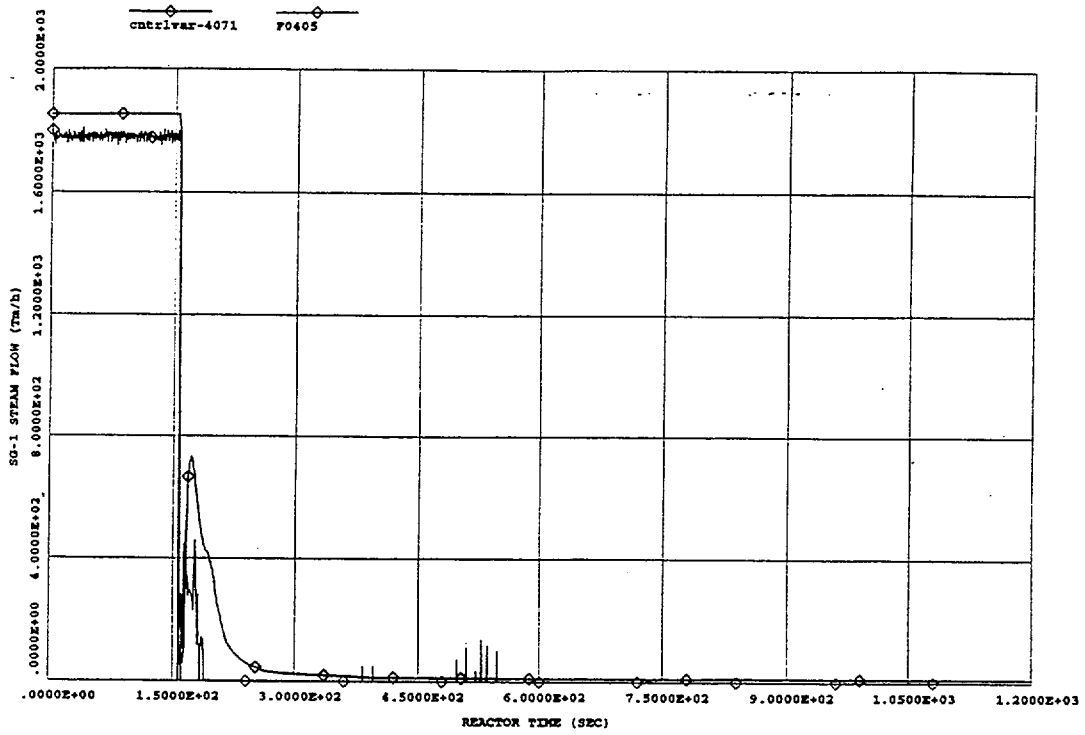

MSIVs INADVERTENT MANUAL CLOSURE (26-6-89)

S.G. 2 steam flow (Tm/h) (RELAP/PLANT)

Figura 32

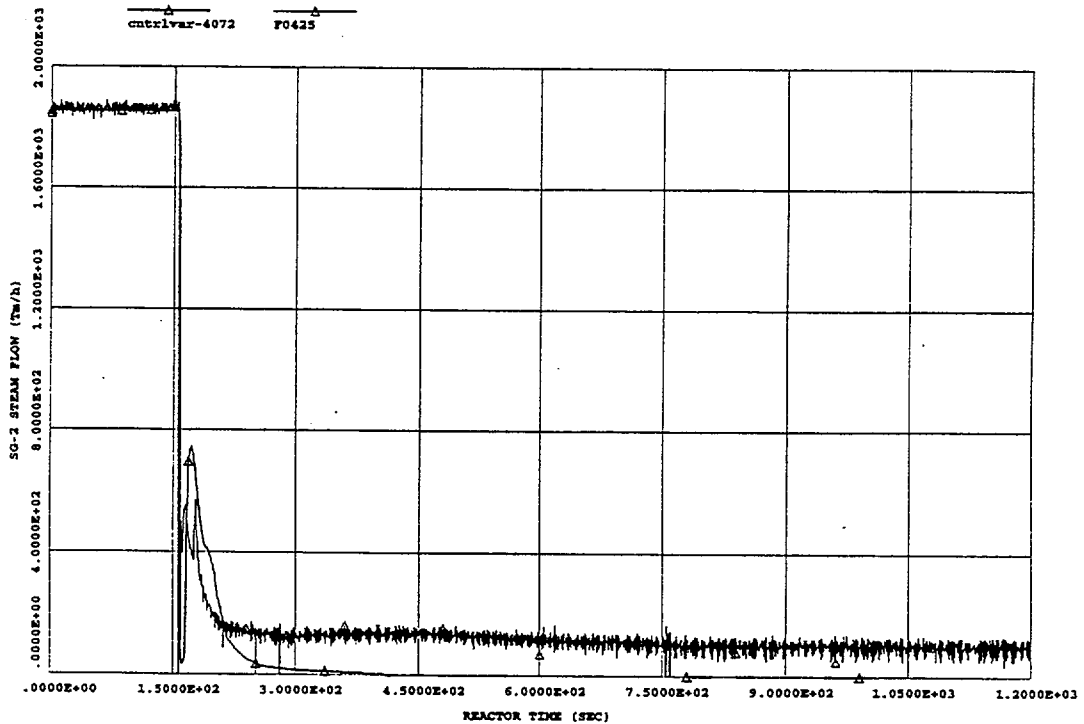

MSIVs INADVERTENT MANUAL CLOSURE (26-6-89)

Figura 33

S.G. 3 steam flow (Tm/h) (RELAP/PLANT)

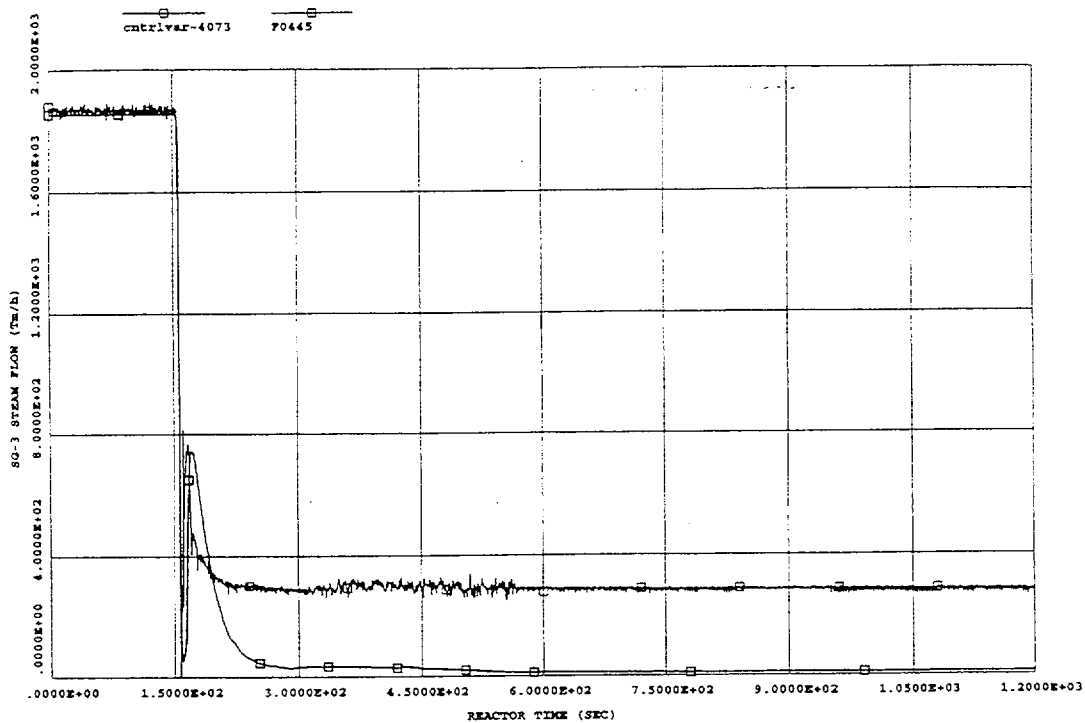

MSIVs INADVERTENT MANUAL CLOSURE (26-6-89)

Figura 34

S.G. 1 MFW flow (Tm/h) (RELAP/PLANT)



Figura 35

MSIVs INADVERTENT MANUAL CLOSURE (26-6-89)

S.G. 2 MPW flow (Tm/h) (RELAP/PLANT)

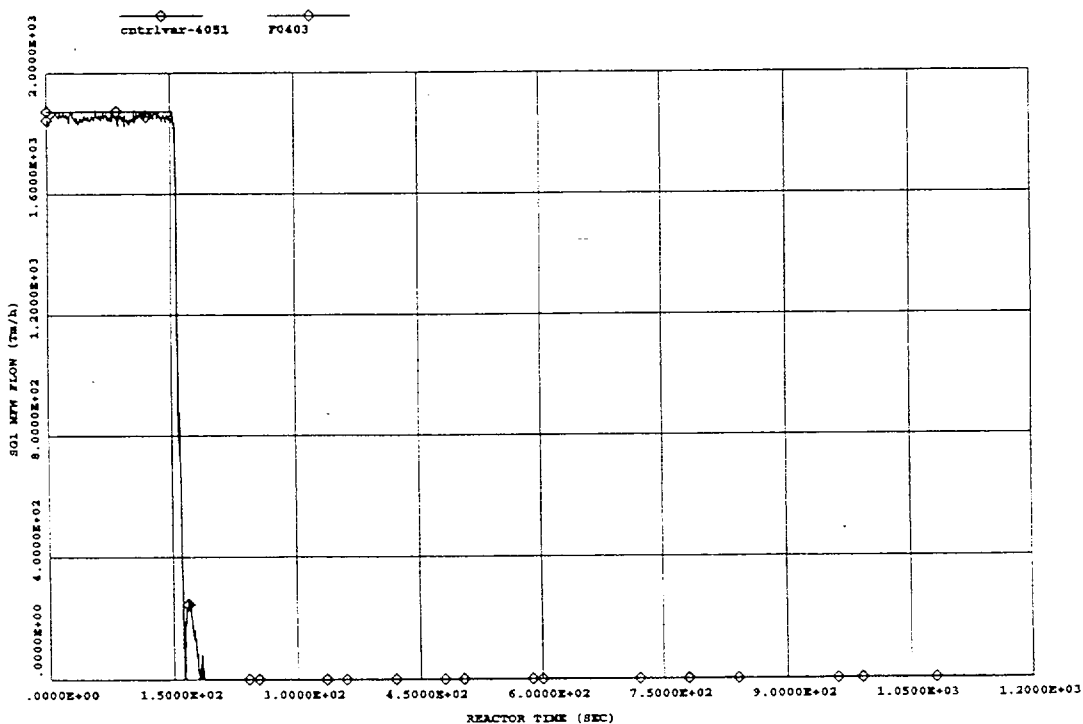

Figura 36

MSIVs INADVERTENT MANUAL CLOSURE (26-6-89)

S.G. 3 MPW flow (Tm/h) (RELAP/PLANT)

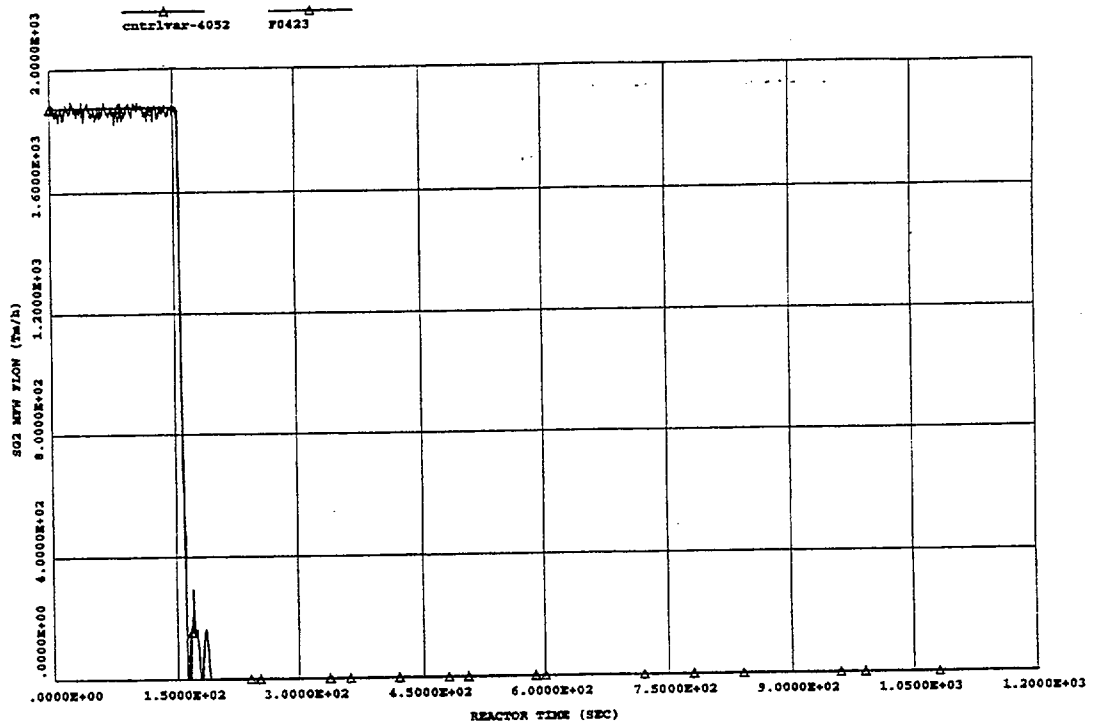
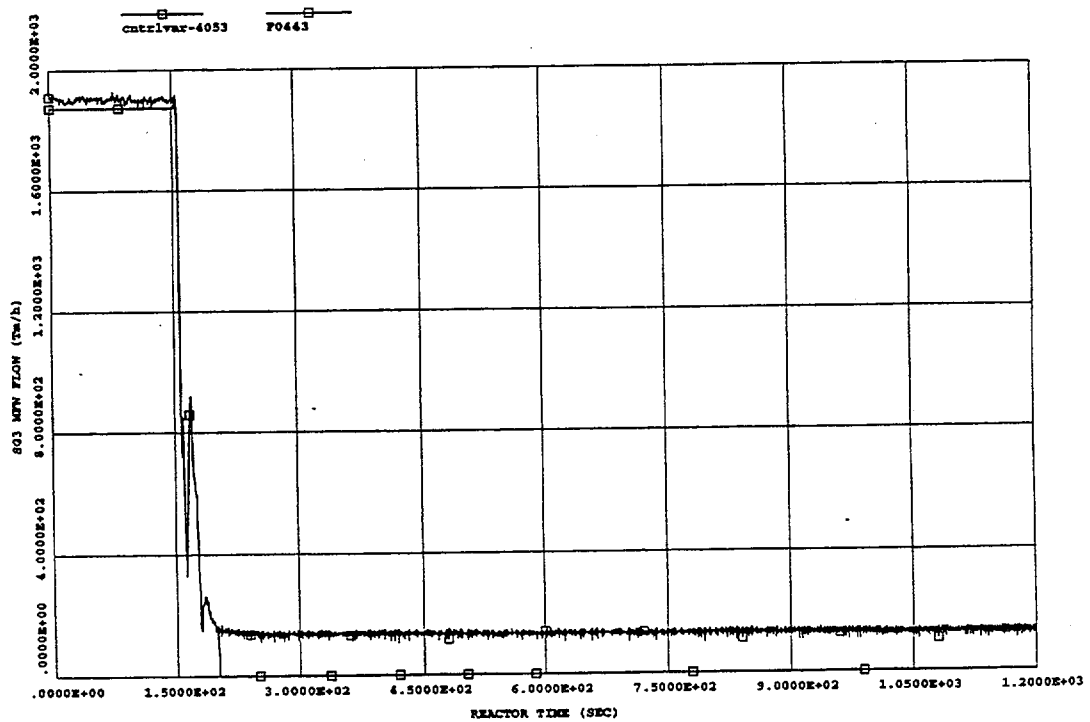

MSIVs INADVERTENT MANUAL CLOSURE (26-6-89)

Figura 37

APW mass flow rates (Tm/h)

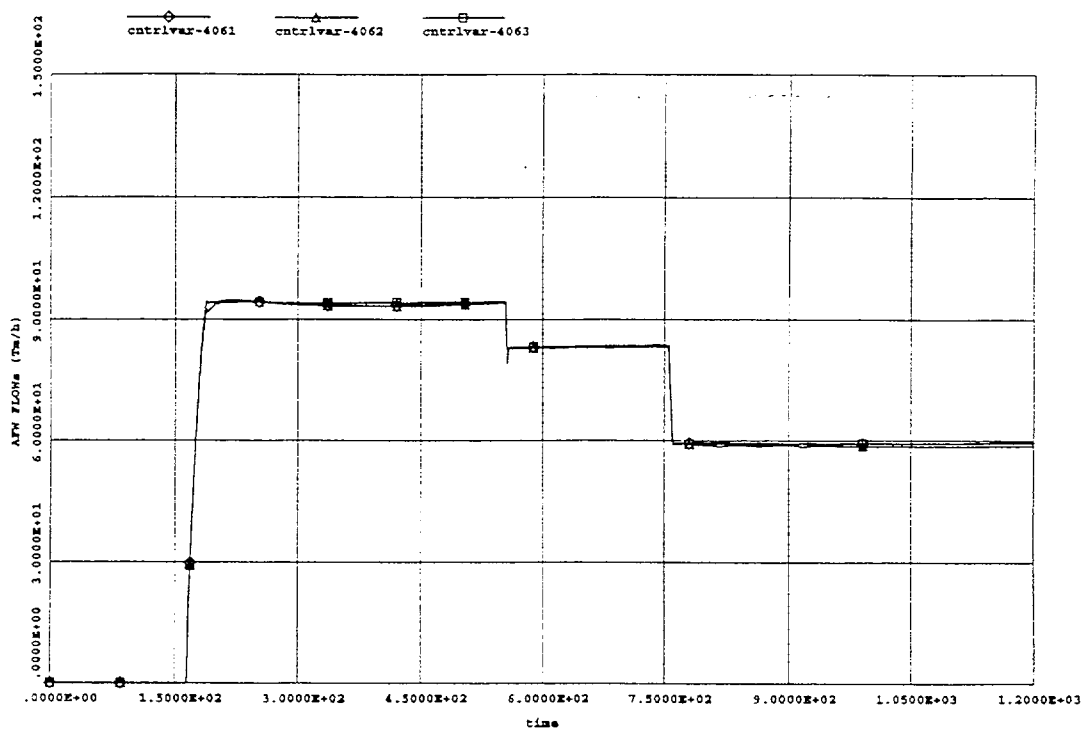

MSIVs INADVERTENT MANUAL CLOSURE (26-6-89)

Figura 38

Pressuriser relief valves mass flow rate (Kg/s)



Figura 39

MSIVs INADVERTENT MANUAL CLOSURE (26-6-89)

Pressurizer safety valves mass flow rate (Kg/s)

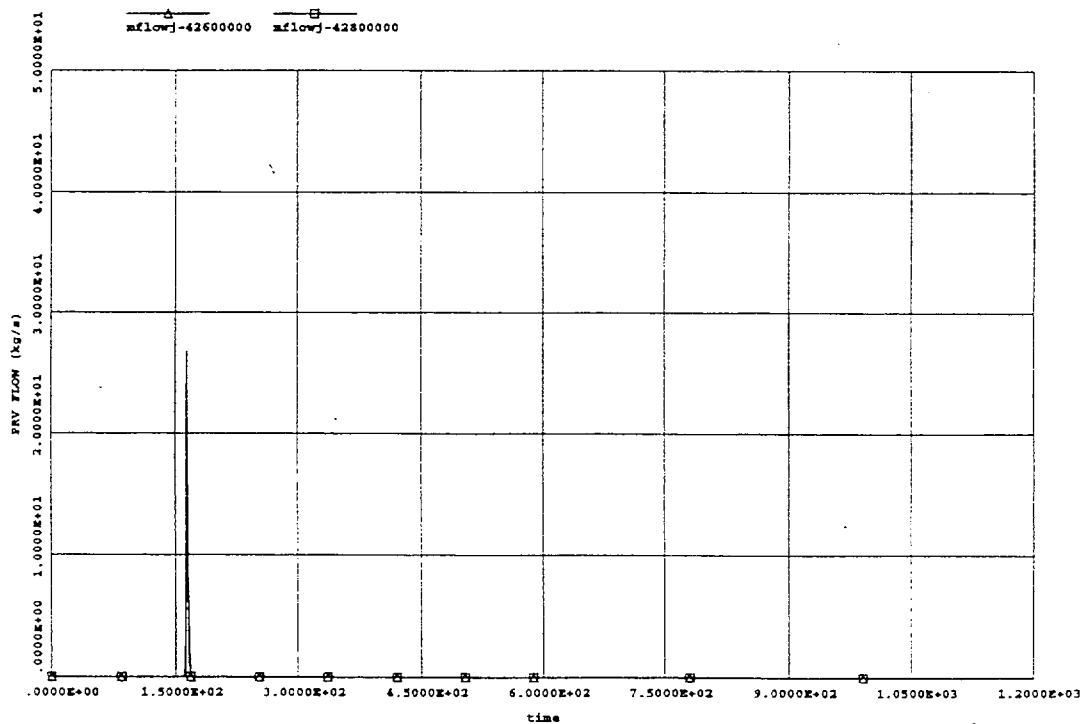

Figura 40

MSIVs INADVERTENT MANUAL CLOSURE (26-6-89)

S.G.1 relief and safety valves discharged mass (Kg/s)



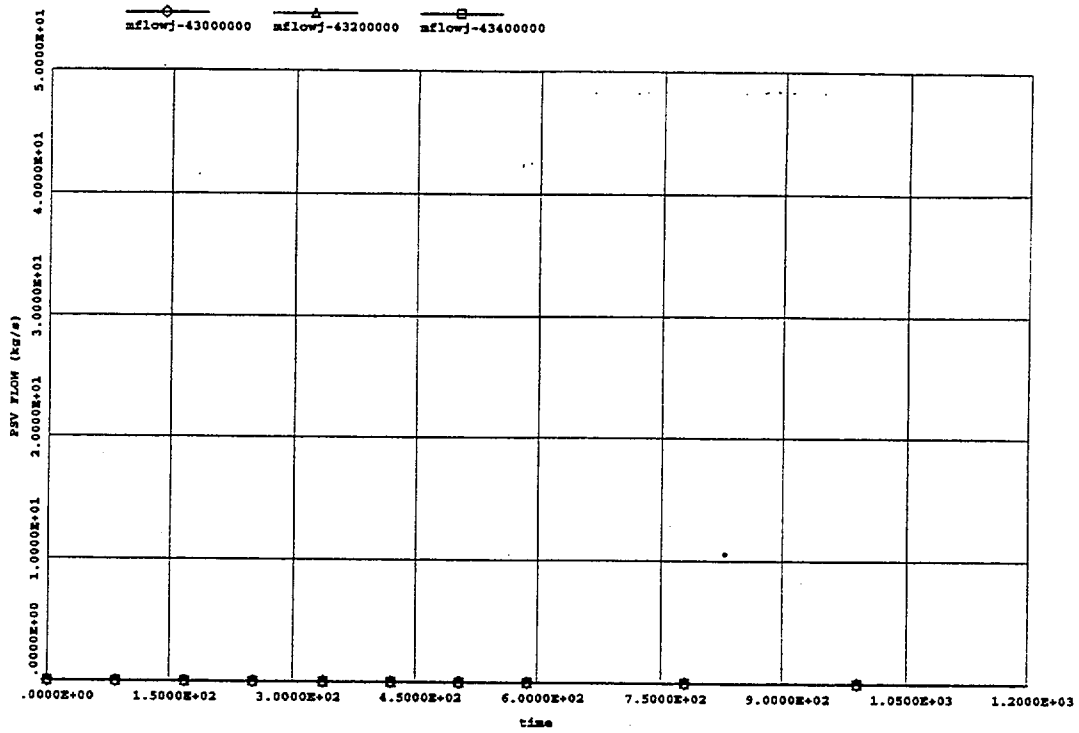
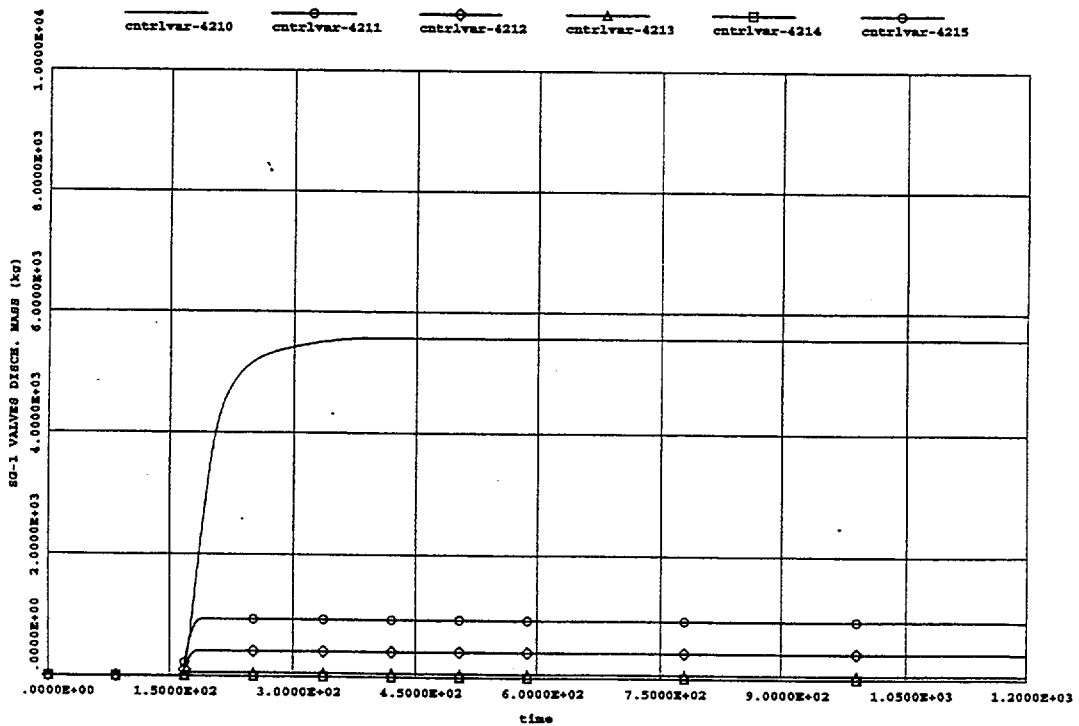
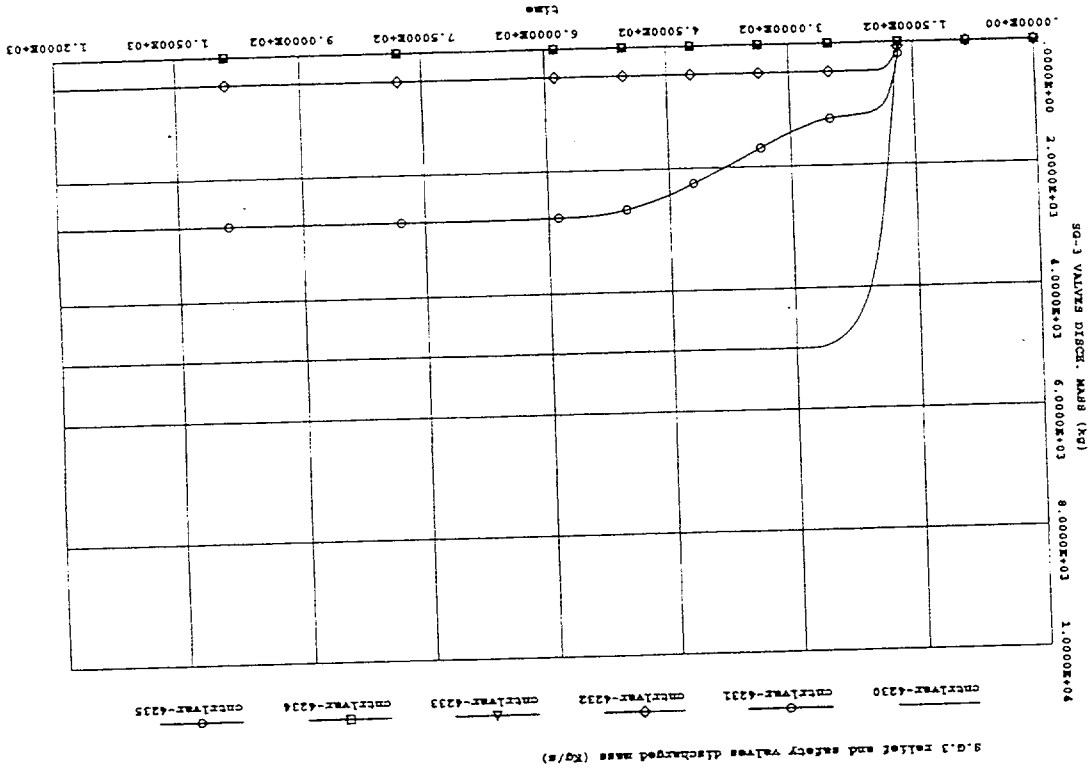

MSVA IMPROVEMENT MANUAL CLOSURE (26-6-89)

Figure 42

VANDERLANS-R

Tecatom S.A.

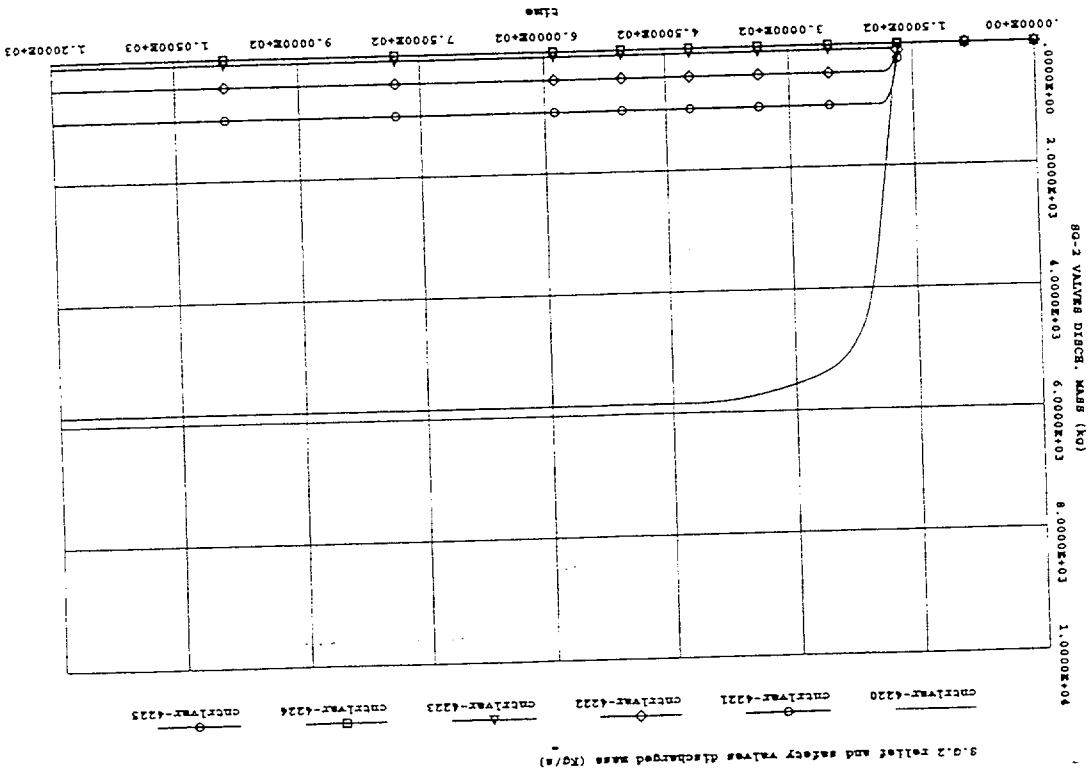

MSVA IMPROVEMENT MANUAL CLOSURE (26-6-89)

Figure 41

VANDERLANS-R

Tecatom S.A.

Figura 43

MSIVs INADVERTENT MANUAL CLOSURE (26-6-89)

Time Step Size (s)

dc-0 ctrlivar-4235



Figura 44

MSIVs INADVERTENT MANUAL CLOSURE (26-6-89)

CPU Time Consumption (s)

cpitime-0 ctrlivar-4235

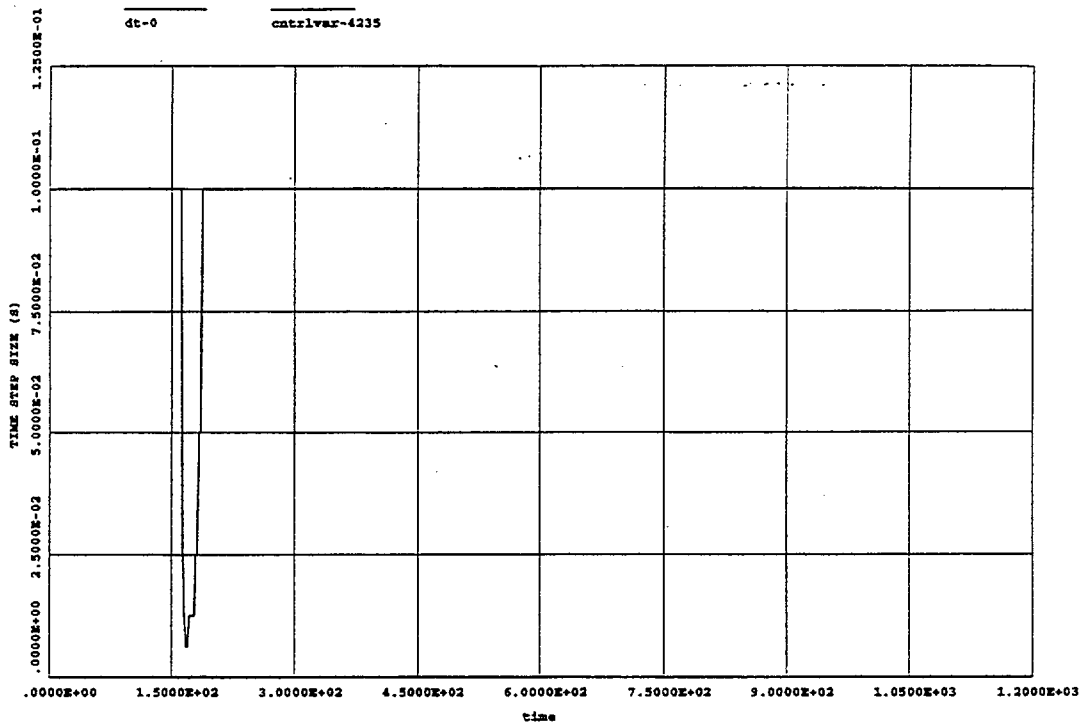
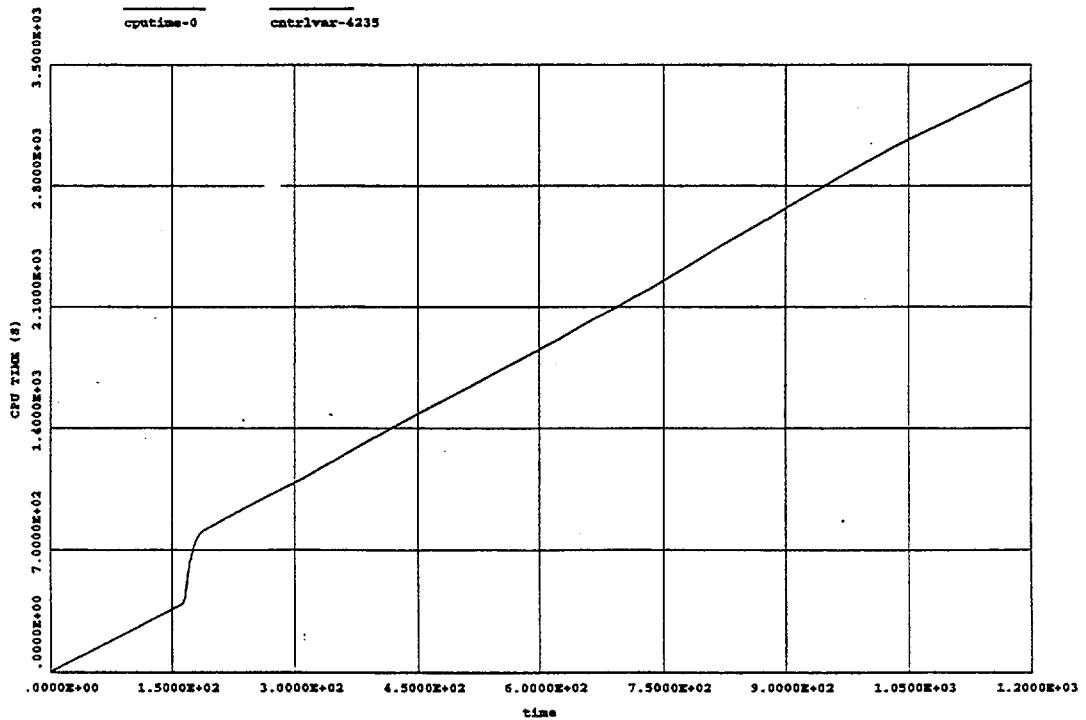

BIBLIOGRAPHIC DATA SHEET

(See instructions on the reverse)

1. REPORT NUMBER
(Assigned by NRC, Add Vol., Supp., Rev.,
and Addendum Numbers, if any.)

NUREG/IA-0197

2. TITLE AND SUBTITLE

Assessment of RELAP5/MOD3.2-NPA3.4 Against an Inadvertent Closure
of all Three MSIV's in VANDELLOS-II Nuclear Power Plant

3. DATE REPORT PUBLISHED

MONTH | YEAR

January | 2001

4. FIN OR GRANT NUMBER

5. AUTHOR(S)

C. Llopis, A. Tanarro, R.M. Fanegas

6. TYPE OF REPORT

Technical

7. PERIOD COVERED (Inclusive Dates)

8. PERFORMING ORGANIZATION - NAME AND ADDRESS (If NRC, provide Division, Office or Region, U.S. Nuclear Regulatory Commission, and mailing address; if contractor, provide name and mailing address.)

TECNATOM
Avda. Montes de Oca, 1,
San Sebastian de los Reyes
28700-Madrid, SPAIN

9. SPONSORING ORGANIZATION - NAME AND ADDRESS (If NRC, type "Same as above"; if contractor, provide NRC Division, Office or Region, U.S. Nuclear Regulatory Commission, and mailing address.)

Division of Systems Analysis and Regulatory Effectiveness
Office of Nuclear Regulatory Research
U.S. Nuclear Regulatory Commission
Washington, DC 20555-0001

10. SUPPLEMENTARY NOTES

11. ABSTRACT (200 words or less)

The work consists in reproducing an actual inadvertent manual closure of all three main steam isolation valves transient that occurred at Vandellos II Nuclear Power Plant (Tarragona, Spain), by means of the RELAP5/MOD3.2 code, thus becoming part of an assessment type exercise. The calculations have been performed by the plant technical support staff and TECNATOM S.A. in a joint effort. Vandellos NPP input model for RELAP5/MOD3.2, has been developed, starting from the input model for the former versions RELAP5/MOD2 and MOD2.5, by the licensee technical services department. The model was provided to TECNATOM S.A., along with the plant data, transient available records and associated information in order to perform the transient calculation and sensitivity studies. Finally, the results and conclusions were discussed and presented jointly by both organizations. The present report is mainly focused on the steady state and transient calculations and the findings and conclusions derived from them. The general purpose model provided by the licensee, along with some little modifications implemented for the specific transient calculation, are described. A thorough description of the model build-up process is not included.

12. KEY WORDS/DESCRIPTORS (List words or phrases that will assist researchers in locating the report.)

MSIV Closure
RELAP5/MOD3.2

13. AVAILABILITY STATEMENT

unlimited

14. SECURITY CLASSIFICATION

(This Page)

unclassified

(This Report)

unclassified

15. NUMBER OF PAGES

16. PRICE

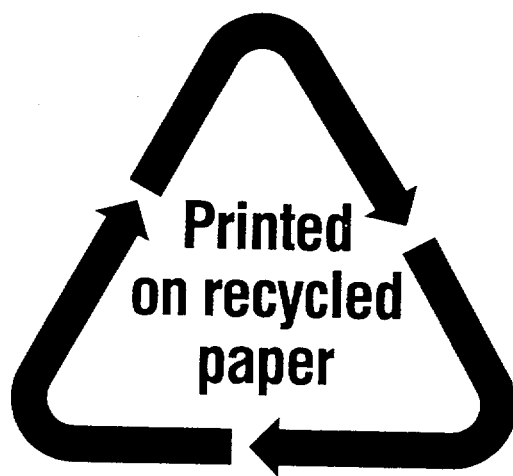

Federal Recycling Program

UNITED STATES
NUCLEAR REGULATORY COMMISSION
WASHINGTON, DC 20555-0001

OFFICIAL BUSINESS
PENALTY FOR PRIVATE USE, \$300