



International Agreement Report

RELAP5/MOD3.2 Validation Using BETHSY Test 6.9a

Prepared by

S. Bouabdallah

NNC Ltd.
Booths Hall
Chelford Road
Knutsford, Cheshire
GB-WA16 8QZ
UNITED KINGDOM

**Office of Nuclear Regulatory Research
U.S. Nuclear Regulatory Commission
Washington, DC 20555-0001**

August 2000

Prepared as part of
The Agreement on Research Participation and Technical Exchange
under the International Code Application and Maintenance Program (CAMP)

**Published by
U.S. Nuclear Regulatory Commission**

AVAILABILITY OF REFERENCE MATERIALS IN NRC PUBLICATIONS

NRC Reference Material

As of November 1999, you may electronically access NUREG-series publications and other NRC records at NRC's Public Electronic Reading Room at www.nrc.gov/NRC/ADAMS/index.html.

Publicly released records include, to name a few, NUREG-series publications; *Federal Register* notices; applicant, licensee, and vendor documents and correspondence; NRC correspondence and internal memoranda; bulletins and information notices; inspection and investigative reports; licensee event reports; and Commission papers and their attachments.

NRC publications in the NUREG series, NRC regulations, and *Title 10, Energy*, in the Code of *Federal Regulations* may also be purchased from one of these two sources.

1. The Superintendent of Documents
U.S. Government Printing Office
P. O. Box 37082
Washington, DC 20402-9328
www.access.gpo.gov/su_docs
202-512-1800
2. The National Technical Information Service
Springfield, VA 22161-0002
www.ntis.gov
1-800-533-6847 or, locally, 703-805-6000

A single copy of each NRC draft report for comment is available free, to the extent of supply, upon written request as follows:

Address: Office of the Chief Information Officer,
Reproduction and Distribution
Services Section
U.S. Nuclear Regulatory Commission
Washington, DC 20555-0001
E-mail: DISTRIBUTION@nrc.gov
Facsimile: 301-415-2289

Some publications in the NUREG series that are posted at NRC's Web site address www.nrc.gov/NRC/NUREGS/indexnum.html are updated periodically and may differ from the last printed version. Although references to material found on a Web site bear the date the material was accessed, the material available on the date cited may subsequently be removed from the site.

Non-NRC Reference Material

Documents available from public and special technical libraries include all open literature items, such as books, journal articles, and transactions, *Federal Register* notices, Federal and State legislation, and congressional reports. Such documents as theses, dissertations, foreign reports and translations, and non-NRC conference proceedings may be purchased from their sponsoring organization.

Copies of industry codes and standards used in a substantive manner in the NRC regulatory process are maintained at—

The NRC Technical Library
Two White Flint North
11545 Rockville Pike
Rockville, MD 20852-2738

These standards are available in the library for reference use by the public. Codes and standards are usually copyrighted and may be purchased from the originating organization or, if they are American National Standards, from—

American National Standards Institute
11 West 42nd Street
New York, NY 10036-8002
www.ansi.org
212-642-4900

The NUREG series comprises (1) technical and administrative reports and books prepared by the staff (NUREG-XXXX) or agency contractors (NUREG/CR-XXXX), (2) proceedings of conferences (NUREG/CP-XXXX), (3) reports resulting from international agreements (NUREG/IA-XXXX), (4) brochures (NUREG/BR-XXXX), and (5) compilations of legal decisions and orders of the Commission and Atomic and Safety Licensing Boards and of Directors' decisions under Section 2.206 of NRC's regulations (NUREG-0750).

DISCLAIMER: This report was prepared under an international cooperative agreement for the exchange of technical information. Neither the U.S. Government nor any agency thereof, nor any employee, makes any warranty, expressed or implied, or assumes any legal liability or responsibility for any third party's use, or the results of such use, of any information, apparatus, product or process disclosed in this publication, or represents that its use by such third party would not infringe privately owned rights.

NUREG/IA-0188



International Agreement Report

RELAP5/MOD3.2 Validation Using BETHSY Test 6.9a

Prepared by

S. Bouabdallah

NNC Ltd.
Booths Hall
Chelford Road
Knutsford, Cheshire
GB-WA16 8QZ
UNITED KINGDOM

Office of Nuclear Regulatory Research
U.S. Nuclear Regulatory Commission
Washington, DC 20555-0001

August 2000

Prepared as part of
The Agreement on Research Participation and Technical Exchange
under the International Code Application and Maintenance Program (CAMP)

Published by
U.S. Nuclear Regulatory Commission

Abstract

This report provides the results of a RELAP5/MOD3.2 calculation of Test 6.9a which was carried out on the BETHSY facility. The purpose of the calculation is to provide validation evidence for the use of RELAP5/MOD3.2 for application to faults at Sizewell B which can occur when the plant is in Modes 5 and 6 (and including the use of nozzle dams).

CONTENTS

1. Introduction	1
2. The BETHSY facility	1
3. Test 6.9a	1
3.1 Test 6.9a description	1
3.2 Relevance of test	3
4. The RELAP5/MOD3.2 model	3
5. Calculation results	3
6. Summary of calculation	7
7. Conclusions	8
8. References	8
9. List of calculations	8
10. List of Figures	9
Figures	F1-F22

1 Introduction

This report provides the results of a RELAP5/MOD3.2 (Ref 1) calculation of Test 6.9a (Ref 2) which was carried out on the BETHSY facility (Ref 3). The purpose of the calculation is to provide validation evidence for the use of RELAP5/MOD3.2 for application to faults at Sizewell B which can occur when the plant is in Modes 5 and 6 (and including the use of nozzle dams).

2 The BETHSY facility

The BETHSY facility is a three loop, full elevation, 1/100 volume scale model of a Framatome three loop PWR of 2775 MWth core power (Ref 3). The BETHSY facility simulates:

- (i) the entire primary circuit - pressure vessel, primary piping for three loops including SG primary sides, coolant pumps and pressuriser connected to the hot leg of loop 1 via a surge line (the surge line is connected to the top of the hot leg)
- (ii) the secondary system consisting of three SG secondary sides, main feedwater lines and main steam lines
- (iii) the emergency auxiliary systems including a High Pressure Injection System, Low Pressure Injection System, accumulators, Auxiliary Feedwater System etc.

The vessel contains a core simulator consisting of 428 full length electrically heated rods and 29 guide thimbles of a design (pitch, diameter and length) typical of a 17 x 17 fuel bundle. The downcomer consists of an external tube connecting the cold legs to the lower plenum of the vessel. The bypass from upper plenum to downcomer top is simulated by pipework with calibrated orifices. Figures 1 to 4 show schematic layouts of the BETHSY facility.

3 Test 6.9a

Test 6.9a (Ref 2) consists of the simulation of a loss of RHR with the plant at mid-loop, decay heat corresponding to 0.5% nominal full power and with the pressuriser manway open. The SGs were filled with air and isolated. Both gravity and forced Safety Injection were used to recover from the fault. The systems were activated dependent on core rod temperatures.

3.1 Test 6.9a description

Test 6.9a (Ref 2) was initiated with the primary system pressure (upper plenum) at 1.15 bar, the water level at mid-loop elevation as described above and with the fluid within most of the primary system stagnant and close to saturation. The space above the liquid was filled with saturated steam.

The start of the test consisted of the core power being ramped from zero to 141 kW (0.5% power) in 15 s and the opening of the valve simulating the pressuriser manway. Boiling occurred very rapidly in the core and this resulted in increasing primary pressure, steam discharge from the manway and level swell in the core and upper plenum. Some steam passed up the guide tube, through the upper head and into the downcomer (henceforth termed the upper head bypass) where it condensed on the water which was slightly subcooled (both initially and due to the rising pressure). Two-phase mixture flowed from the upper plenum into the guide tube, the hot legs, the surge line and the pressuriser. Liquid continued to be entrained with the vapour into the surge line and pressuriser and the level in the pressuriser continued to rise causing the system pressure to increase. The boil-off of liquid led to draining of the cold legs so that condensation in the downcomer ceased, the upper head bypass flow fell and at about 2000 s the guide tube drained. By 2400 s the two-phase mixture in the pressuriser had risen to the top so that between 2400 s and 2600 s some liquid was entrained with the vapour out of the manway. Further discussion of liquid discharge through the manway is provided in section 5.

By about 2900 s the upper plenum level fell below the hot leg elevation so that only steam flowed into the pressuriser. As the boil-off continued, the level in the upper plenum continued to fall and at about 5000 s the top of the core became uncovered. The uncovered core started to heat up, the rate of steam generation fell and the system pressure fell.

At 6045 s gravity injection to cold leg 1 was initiated in response to the hottest rod temperature reaching 250°C. The mixture level in the core rose slowly but the upper part of the core continued to heat up. Vapour flow from the core via the upper head bypass increased and the vapour condensed on the cold injection water in cold leg 1 and the downcomer. The resulting fall in system pressure aided the gravity injection since the flow was proportional to the differential pressure between the injection source at 1.5 bar and cold leg 1. The injection flow was not of sufficient magnitude to remove all the decay heat and so the mixture level in the core continued to fall, whilst the core continued to heat up.

At 7060 s the rod temperature had reached 400°C, gravity injection was terminated and pumped injection to cold leg 1 was initiated. The pumped injection rapidly refilled the core, with total core quench being complete by 8040 s. By 9500 s the mixture level in the upper plenum had reached the elevation of the hot legs, resulting in the further entrainment of liquid into the hot legs, surge line and pressuriser, with further liquid discharge from the manway. The upper head bypass steam flow increased because of the increased condensation potential of the injection flow. The bypass steam flow then fell as the cold legs became water-filled, with condensation then only occurring in the top of the downcomer. The test was effectively terminated at 12410 s when the core power was turned off.

3.2 Relevance of test

The phenomena occurring in the test which are judged to be of most importance for the validation of RELAP5/MOD3.2 for application during Modes 5 and 6 (and including use of nozzle dams) are the following:

- (i) level swell in the core and upper plenum
- (ii) liquid carry-over into the hot legs
- (iii) counter-current flow and pressuriser surge line flooding
- (iv) RCS pressurisation and gravity drain
- (v) upper head bypass flow and condensation.

4 The RELAP5/MOD3.2 model

The RELAP5/MOD3.2 model of the BETHSY facility is based upon that developed originally by INEL for the RELAP5/MOD3 (development version 7 vq) analysis of ISP-27 (BETHSY Test 9.1.b). The model has subsequently been revised for application with more recent versions of RELAP5/MOD3 and for application to BETHSY Test 6.9a. The noding scheme is shown in Fig 5 to 8.

5 Calculation results

The most significant results of the calculation are compared with the experimental results in Fig 9 to 22. Experimental results are shown with a solid line and the results of the RELAP5/MOD3.2 calculations are shown with a dashed line.

Figure 9 shows the pressuriser pressure. There was an initial fall in pressure due to the manway opening, but this was halted as liquid began flashing to steam. The pressure subsequently rose due to boiling as the core heat reached its steady value at 15 s. As the pressure rose, steam was discharged from the manway (Fig 10). The measured pressure reached a peak of about 1.06 bar at about 2000 s when the steam relief at the manway approximately balanced the steam generation in the core. In the calculation the initial pressure fall was greater and the subsequent pressure rise was greater, but was delayed compared to the test. Figure 11 shows the pressure in the loop 1 cold leg. The entrainment of a two-phase mixture from the vessel into the surge line and pressuriser led to a higher pressure in the cold leg than at the top of the pressuriser. The pressure differentials across the pressuriser and surge line are shown in Fig 12 and 13 respectively. After about 2500 s, RELAP5/MOD3.2 is calculating a pressure differential in the pressuriser greater than measured by about 0.1 bar. Since the velocities and thus dynamic pressure across the pressuriser are small, this suggests that the calculation is entraining too much liquid into the pressuriser. This is believed to be due to the interfacial drag model in RELAP5/MOD3.2 which overpredicts the drag between the liquid and vapour phases. This causes an overprediction of the level swell within the core and

upper plenum and thus in the hot legs resulting in too much liquid being entrained with the steam into the surge line and pressuriser. The differential pressure across the surge line was reasonably well calculated. There was an initial peak in differential pressure (reasonably well calculated), presumably due to the initial surge of low quality fluid driven through the surge line by the initial level swell in the vessel. Because the cross-sectional area of the pressuriser is about 24 times that of the surge line, this increase in differential pressure is not observed in the pressuriser as the low quality fluid enters the pressuriser. In both the pressuriser and surge line, a peak in the differential pressure occurred in the test at about 2000 s, whereas the peak was calculated to occur at about 2750 s. The effect of these differential pressure peaks is reflected in the cold leg pressure which peaked at the same time (Fig 11). The pressure differential across the pressuriser is, because of the relatively low fluid velocities in the pressuriser, effectively a measure of the mass of liquid in the pressuriser. This mass initially increased as the pressuriser filled up with a two-phase mixture, and then fell to a stable value following the discharge of liquid out of the manway. Liquid discharge is claimed to occur in the test at either 2400 s to 2600 s (page 17 of Ref 2) or 2900 s to 3000 s (page 20 of Ref 2). Note that the experimental data shown in Fig 10 does not record liquid discharge. It can be deduced from the integrated manway discharge shown in Fig 4.14 of Ref 2 (reproduced as Fig 14), that liquid discharge through the manway occurred between about 1900 s and 2300 s. This is consistent with the fall in differential pressures in the surge line (Fig 13) and pressuriser (Fig 12) and the fall in cold leg pressure, which occurred between about 2000 s and 3000 s (Fig 11). Figure 19 also confirms increased discharge from the manway during the period from 1900 s to 2300 s. All of these pressures and differential pressures are reduced to steady values by 3000 s, reflecting the steady static heads in the surge line and pressuriser, since the liquid masses in the two regions remain constant, with steam discharge out of the manway and steam inflow from the loop 1 hot leg. Liquid discharge was calculated to occur between about 2200 s and 3100 s (Fig 10). The total quantity of liquid discharged through the manway was calculated to be considerably more than occurred in the test (Fig 14). In the calculation, the peaks in pressures and differential pressures were delayed compared to the test due to condensation effects described below and due to liquid discharge from the manway.

The system pressure is affected by steam discharge from the manway and by condensation of steam on the slightly subcooled water in the downcomer and in the cold legs after the cold legs have drained sufficiently to form a mixture level. The calculated pressures in the loop 1 cold leg (Fig 11) and in the pressuriser (Fig 9) were initially below those in the test due to overprediction of condensation, since the steam discharge from the manway is well predicted (Fig 10 and 14). The steam condensing in the downcomer and cold legs was drawn through the guide tube and upper head bypass. Figure 15 shows the flowrate, whilst Fig 16 shows the pressure drop across the guide tube. The calculation exhibits considerable two-phase flow, whereas only steam flow occurred in the test. Note that the single BETHSY guide tube extends from the upper head down to an elevation approximately half way between the upper core plate and the bottom of the hot leg. It is open at the bottom and has three slots near the bottom. In contrast, the

Sizewell B guide tubes extend down to the upper core plate and have slots at approximately the same elevation as the slots in the BETHSY guide tube. The fact that the Sizewell B guide tubes extend down to the upper core plate and thus draw flow directly from the core may have a significant effect on the flow behaviour in the upper plenum and bypass.

When the condensation ceased (1900 s in the test and 2600 s in the calculation (Fig 16 and 17)), the cold leg pressure continued to rise. However, in both test and calculation, shortly after condensation ceased the liquid discharge from the manway ceased and the cold leg pressure fell (Fig 11) due to the greater steam relief. The calculated cold leg pressure remained above that of the test due to the greater liquid hold-up in the pressuriser (Fig 12).

The void fractions in the cold and hot legs of loop 1 are shown in Fig 17 and 18 respectively. The cold leg started to void at about 100 s in both test and calculation and was empty by 2000 s in the test and 2600 s in the calculation. Note that it is believed that the maximum void fraction of 0.87 observed in the data corresponds to complete voidage and is the result of a calibration error.

The total mass inventory in the primary circuit is shown in Fig 19. The inventory reflects the manway discharge (Figs 10 and 14), with the higher discharge in the calculation during the first 6000 s (Fig 10) resulting in a lower inventory. The liquid discharge from the manway, calculated to occur between 2200 s and 3100 s, was considerably higher than measured and resulted in the significant underprediction of mass inventory until after injection refilled the system. The underprediction of mass inventory was contributed to by the mass loss error inherent in RELAP5/MOD3.2 calculations. The maximum mass error (a loss) was only about 2% at the time of minimum inventory (Fig 22).

After the hot leg had emptied, the vessel level fell due to the continuing boil-off and the top of the core started to uncover at about 5000 s in the test and about 5500 s in the calculation. This can be seen in Fig 20, which shows the core heat-up of the hottest rod. It is evident that the heat-up rate is greater in the calculation than in the test. The uncovering of the top of the core reduced the rate of steam production and hence reduced the discharge from the manway (Fig 10). The primary system pressure started to fall (Fig 9 and 11). The fall in pressuriser pressure was much more severe in the calculation than in the test, this reflecting the fact that at the elevation of the pressuriser pressure tap (cell 5308 in the RELAP deck), the mixture level in the pressuriser fell through cell 5308 and thus reduced the static pressure at that elevation. This did not occur in the test. This supports the belief that RELAP5/MOD3.2 overcalculates the interfacial drag and this caused excessive liquid to be drawn into the pressuriser earlier in the calculation. The pressure differential across the pressuriser did not change significantly in the test or calculation during this period (Fig 12), suggesting that the liquid content within the pressuriser was not affected by the falling steam flow and that the pressure differential was caused by the liquid content in the pressuriser, this dominating the pressure differential due to the steam flow. However, the pressure differential across the surge line fell in both test and calculation, this being due to the reduced

frictional pressure loss due to the reduced steam flow, there being little liquid held in the surge line. Since the fall in surge line differential pressure results from the fall in steam generation in the core due to the uncover, and since the fall in differential pressure in the calculation is greater than that in the test, this suggests a more severe uncover in the calculation than occurred in the test.

When the maximum rod temperature reached 250 °C, the gravity injection was initiated. The injected flows began at 6045 s in the test and at about 6090 s in the calculation, as shown in Fig 21. In the test the gravity injection flow was slightly greater than the manway flow (Fig 10) and this caused a slight increase in the primary system mass inventory (Fig 19). Because of the higher cold leg pressure in the calculation (Fig 11), the injection flow was less than the manway flow (Fig 21 compared to Fig 10) and so the inventory continued to fall (Fig 19). The injection flow caused an increase of bypass steam flow (Fig 15) due to increased condensation in the downcomer and loop 1 cold leg. Because of the lower injection flow in the calculation, the bypass flow was much lower than in the test until pumped injection began. The condensation contributed to the reduction in the pressure in the cold leg (Fig 11) and the pressuriser (Fig 9) and thus reduced the manway flow (Fig 10). The effect of the condensation can be seen in the loop 1 cold leg with a reduction of the void fraction in both the test and the calculation (Fig 17). However the effect of the injection on the core was such as to increase the rate of heat-up because the subcooling of the injection flow reduced the boiling in the covered part of the core and therefore the steam cooling of the uncovered part of the core was reduced. Because of the faster heat-up rate in the calculation, the maximum core temperature reached 400 °C at 6450 s and pumped injection was initiated (Fig 21). The pumped injection started at 7100 s in the test.

In both test and calculation the initial injection flow was much greater than the manway flow and refilling of the primary system occurred. The injection flow was subsequently increased in a step-wise manner as shown in Fig 21. The peak core temperatures occurred at 7480 s in the test and 6940 s in the calculation and complete core quench occurred at 8040 s and 7940 s respectively. The increase in steam generation during the rapid core quench caused an increase in the system pressure in both test and calculation (Fig 9 and 11), the increase in pressure in the calculation being much more than in the test. In the calculation the increased steam flow into the pressuriser increased the surge line differential pressure (Fig 13) and entrained liquid out of the manway between 7000 s and 8000 s (Fig 10). In the test there was no liquid discharge from the manway during the core quench period (Fig 14). This provides further confirmation of the effect of the over-calculation of interfacial drag in RELAP5/MOD3.2 and its effect on entraining too much liquid with the steam into the upper plenum, hot legs and pressuriser.

The relatively higher injection flowrates after 8000 s resulted in more significant condensation on the pumped injection water in the loop 1 cold leg (Fig 17). This resulted in a fall in pressure in the system (Fig 9 and 11).

By 9000 s in the calculation, the vessel had filled up to the hot legs and liquid began to be entrained into the loop 1 hot leg (Fig 18) and the surge line and then into the pressuriser, increasing the differential pressures across the surge line and pressuriser (Fig 13 and 12) and thus the cold leg pressure (Fig 11). Flow into the hot leg did not occur in the test until about 9500 s (Fig 18) and into the pressuriser until after 10000 s (Fig 12). The calculated differential pressure across the pressuriser (a measure of the liquid mass in the pressuriser) remained above that measured (Fig 12) and resulted in considerable liquid discharge through the manway after 10400 s in the calculation and after 11000 s in the test (Fig 10 and 14). The loop 1 cold leg became nearly-filled in both the test and the calculation at about 10000 s and remained full (Fig 17).

The rising level in the upper plenum resulted in the calculation of two-phase flow through the upper head bypass after 10500 s (Fig 15), in contrast to the test which only exhibited vapour flow. In the test the vapour flow gradually fell as the cold leg filled until the condensation was only occurring at the top of the downcomer and the flow became negligible. In the calculation, the two-phase flow continued until the end of the calculation (Fig 15).

6 Summary of calculation

The calculation exhibited the following compared to the test:

- (i) Excessive two-phase flow into hot legs, surge line, pressuriser and out of the manway. This is believed to be the result of the interfacial drag model in RELAP5/MOD3.2.
- (ii) Too much condensation in the downcomer and cold legs. The effect of over-calculating the condensation rate on a fault such as this is complex. For example it reduces pressure which increases the condensation rate further by increasing injection flow and drawing more fluid through the bypass (a positive feedback process). The fall in pressure may also increase flashing and level swell in the core. From the results of the calculation it can be concluded that the conservatively low mass inventory resulting from the interfacial drag model more than outweighs any benefits resulting from the effects of over-calculating condensation.
- (iii) A more rapid core heat-up during the core uncover. It is believed that this is caused by the calculation of too deep a core uncover as a result of underpredicting the primary system mass inventory. The deeper uncover results in reduced steam generation in the covered part of the core and hence reduced steam cooling of the uncovered part of the core.
- (iv) A delay in the time at which core uncover begins. This is believed to be caused by the interfacial drag model resulting in excessive level swell.

There was also a mass loss from the system during the calculation. This amounted to approximately 18 kg by the end of the calculation. At the time of minimum mass in the system the mass loss was only about 2%.

7 Conclusions

A RELAP5/MOD3.2 calculation of BETHSY Test 6.9a has been performed to provide validation evidence for the application of RELAP5/MOD3.2 to faults in Modes 5 and 6 (including the use of nozzle dams).

The results show that all the major phenomena of the test were calculated. The major concerns with regards to RELAP5/MOD3.2 resulting from this validation relate to the over-prediction of interfacial drag between the liquid and vapour phases and the over-prediction of condensation. The over-prediction of interfacial drag can have effects on level prediction, break and other flows and condensation. Care will have to be taken when applying RELAP5/MOD3.2 to reactor calculations to ensure that uncertainties due to the errors introduced by the interfacial drag model are accounted for in a conservative fashion. For example, the delay in core uncovering shown by the calculation, resulted from the interfacial drag model causing an over-prediction of level swell. This calculational effect may, under other circumstances, result in the calculation of no core uncovering whereas a shallow core uncovering could in practice occur.

The calculation also exhibited the mass loss error inherent in RELAP5/MOD3.2 calculations; although the maximum mass loss was only about 2% and did not seriously affect the calculation.

8 References

- | Ref | Title |
|-----|--|
| 1 | NUREG/CR-5535. RELAP5/MOD3 Code Manual. The RELAP5 Code Development Team. June 1995. |
| 2 | STR/LES/92-111. BETHSY Test 6.9a. Loss of Residual Heat Removal System during Mid-loop Operation. Pressuriser Manway Open. Test report. G Laviolle. December 1992. |
| 3 | SETh/LES/90-97. BETHSY General Description. April 1990. |

9 List of calculations

Calc note number	Issue	Status
C5166/CAL/371	01	P

10 List of figures

Fig	Title
1	Schematic diagram of rig circuits
2	Primary cooling system - top view
3	Primary cooling system - elevations
4	Pressure vessel - general view
5	RELAP5/MOD3.2 BETHSY overall noding scheme
6	RELAP5/MOD3.2 BETHSY vessel noding scheme
7	RELAP5/MOD3.2 BETHSY loop 1 noding scheme
8	RELAP5/MOD3.2 BETHSY loops 2 and 3 noding scheme
9	Pressuriser pressure
10	Manway flowrate
11	Cold leg 1 pressure
12	ΔP across the pressuriser
13	ΔP across the surge line
14	Integrated manway discharge
15	Upper head bypass flowrate
16	ΔP across the guide tube
17	Cold leg 1 void fraction
18	Hot leg 1 void fraction
19	Primary system mass inventory
20	Hottest rod maximum temperature
21	Gravity and pumped injection flowrate
22	RELAP5/MOD3.2 mass error

Figure 1 - Schematic diagram of rig circuits

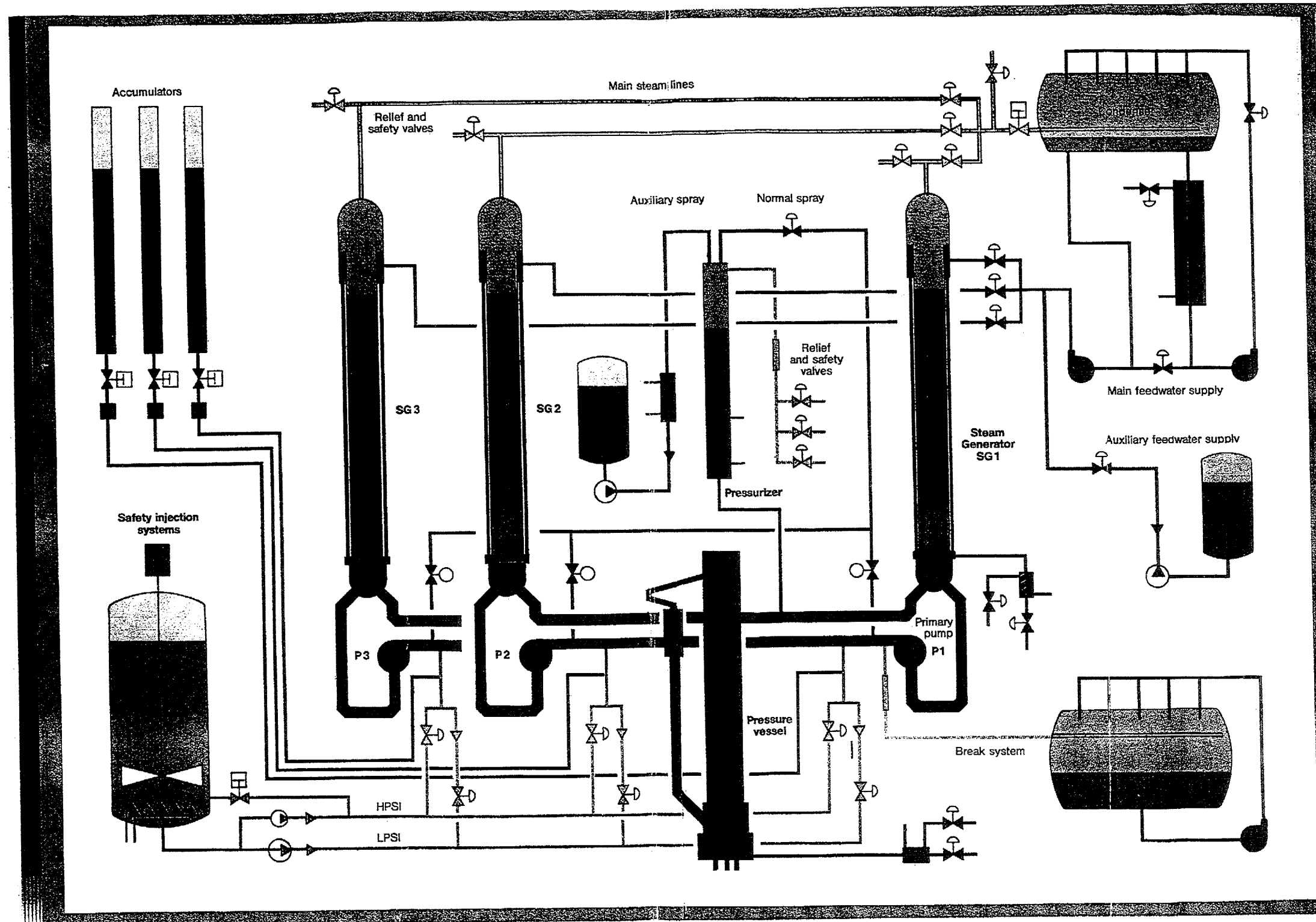

Figure 2 - Primary cooling system - top view

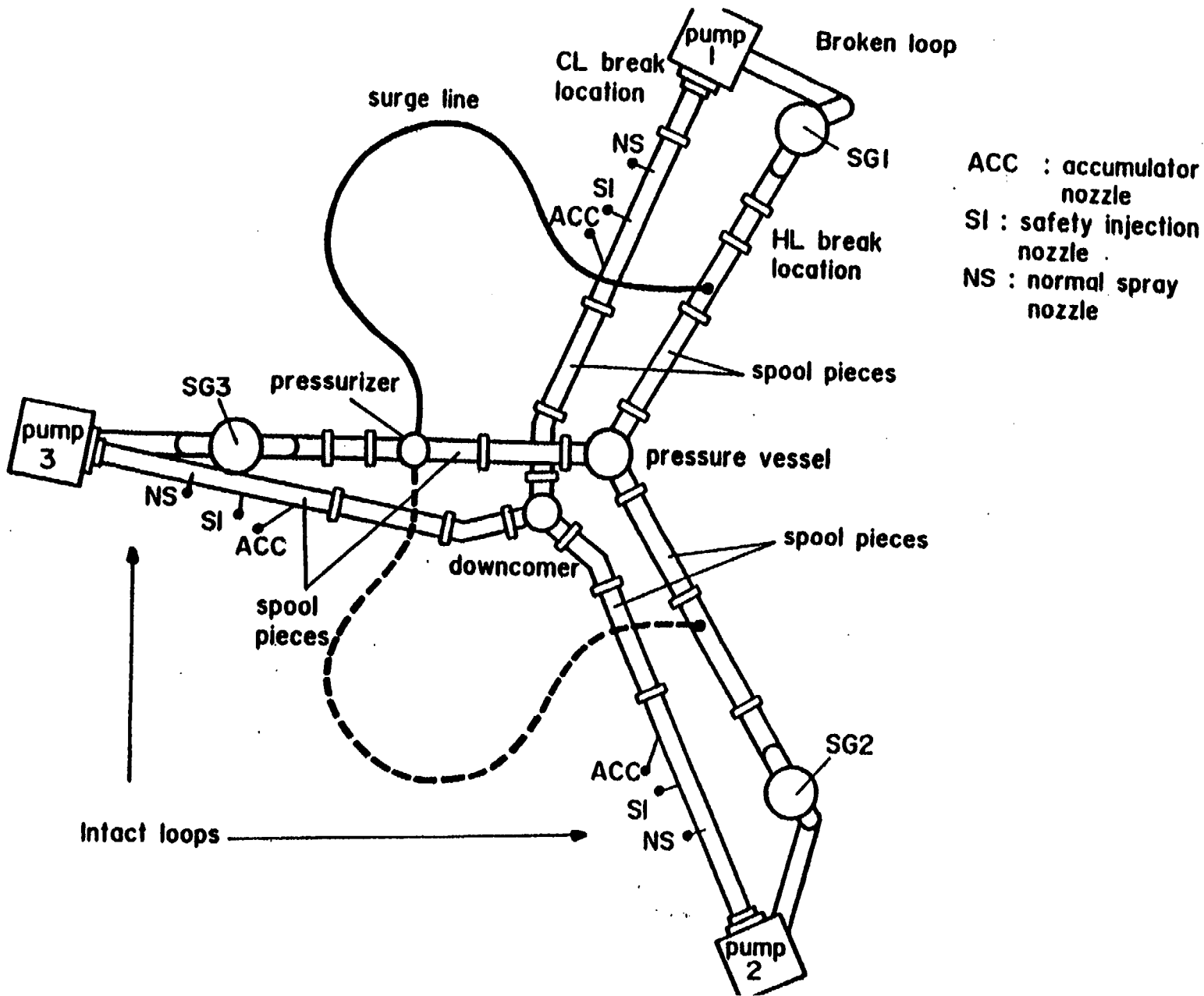

Figure 3 - Primary cooling system - elevations

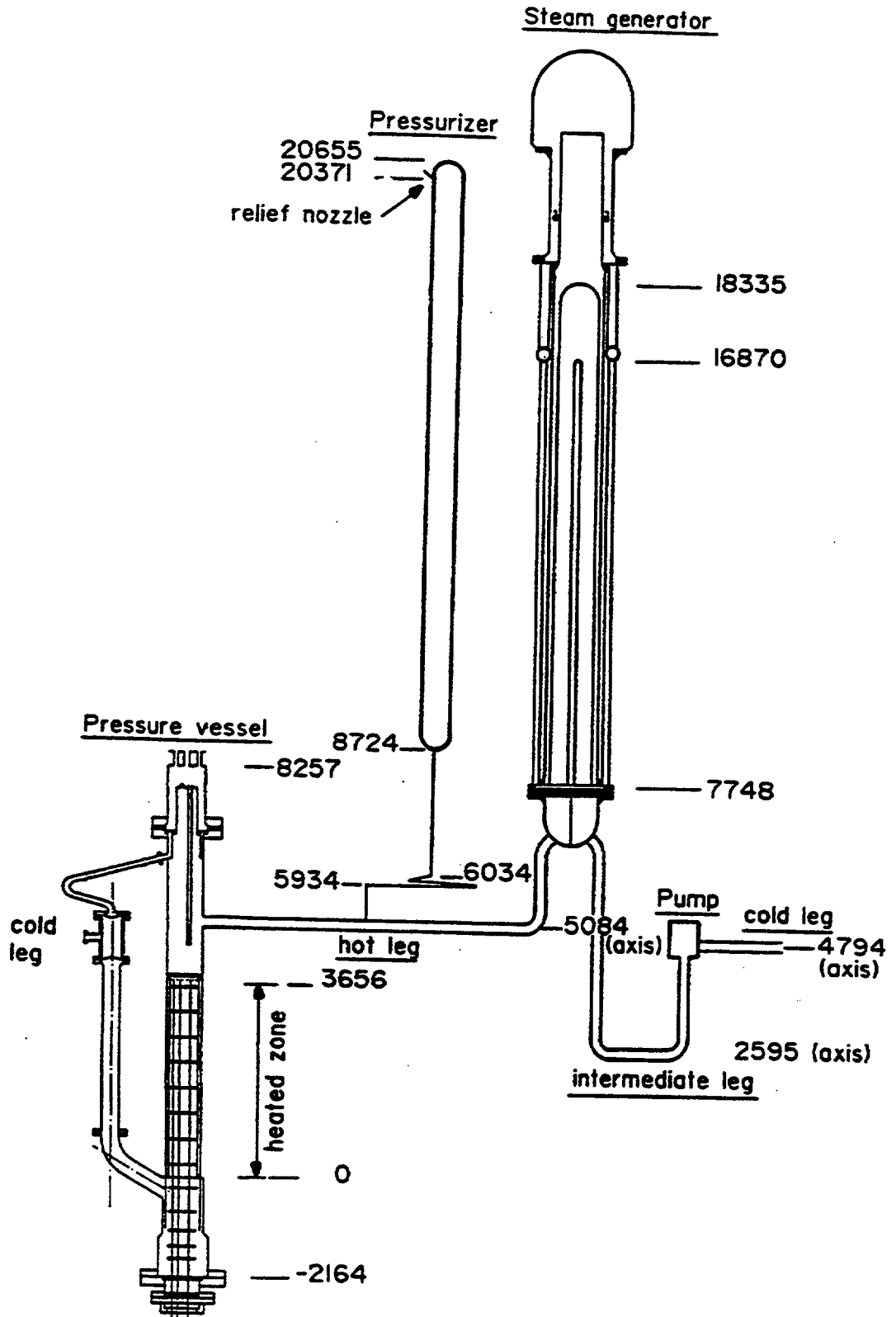

Figure 4 - Pressure vessel - general view

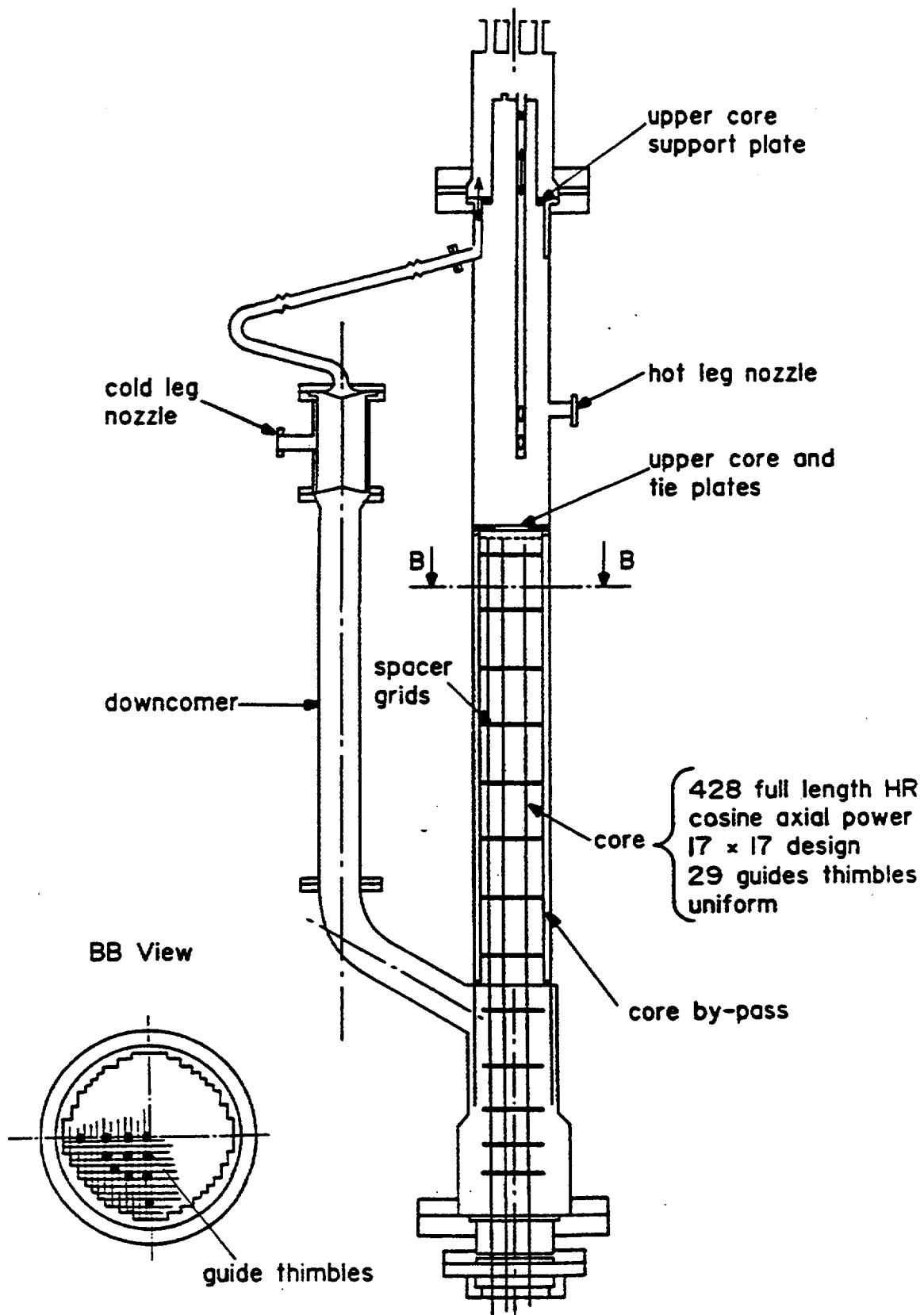

Figure 5 - RELAP5/MOD3.2 BETHSY overall noding scheme

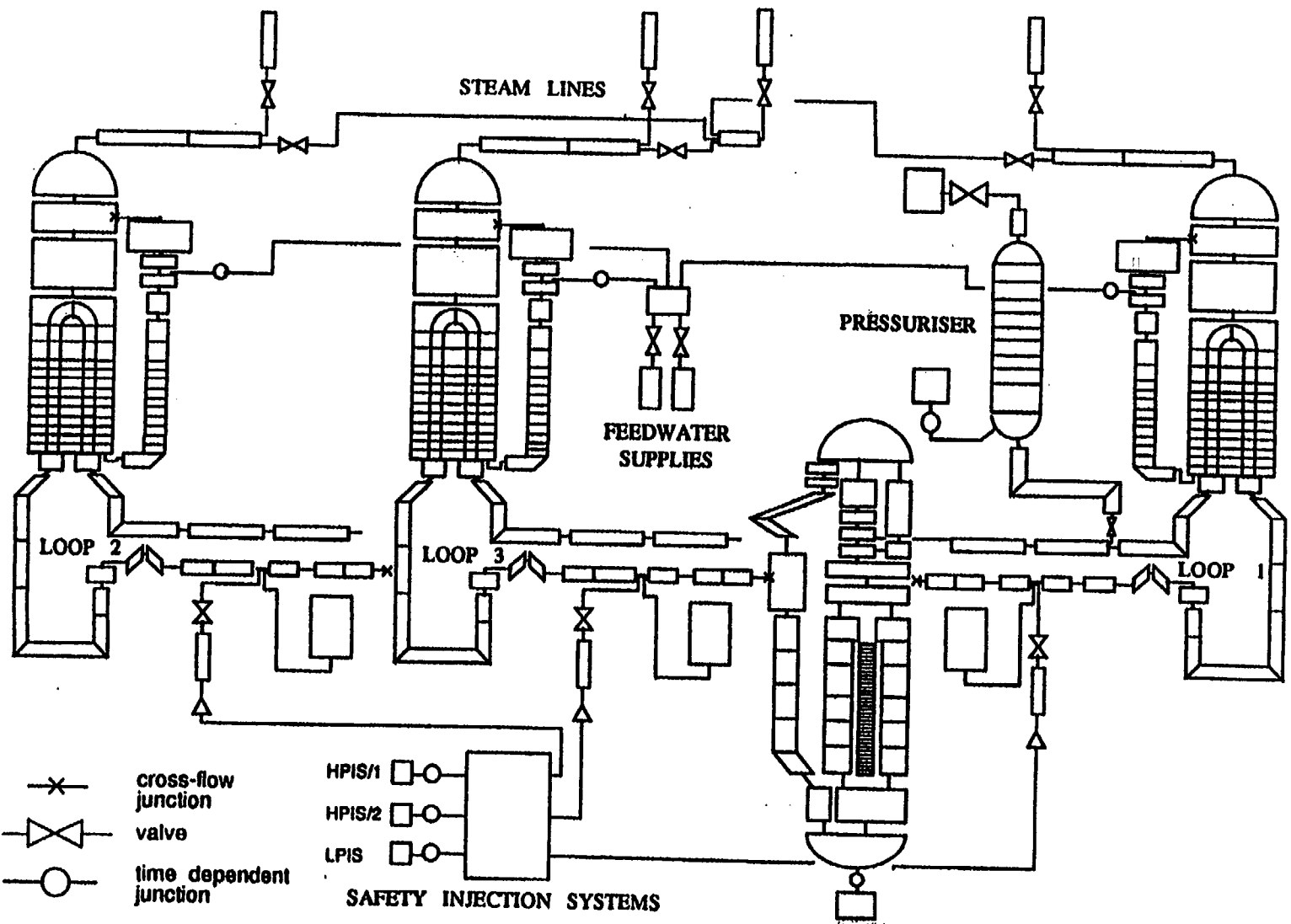

Figure 6 - RELAP5/MOD3.2 BETHSY vessel noding scheme

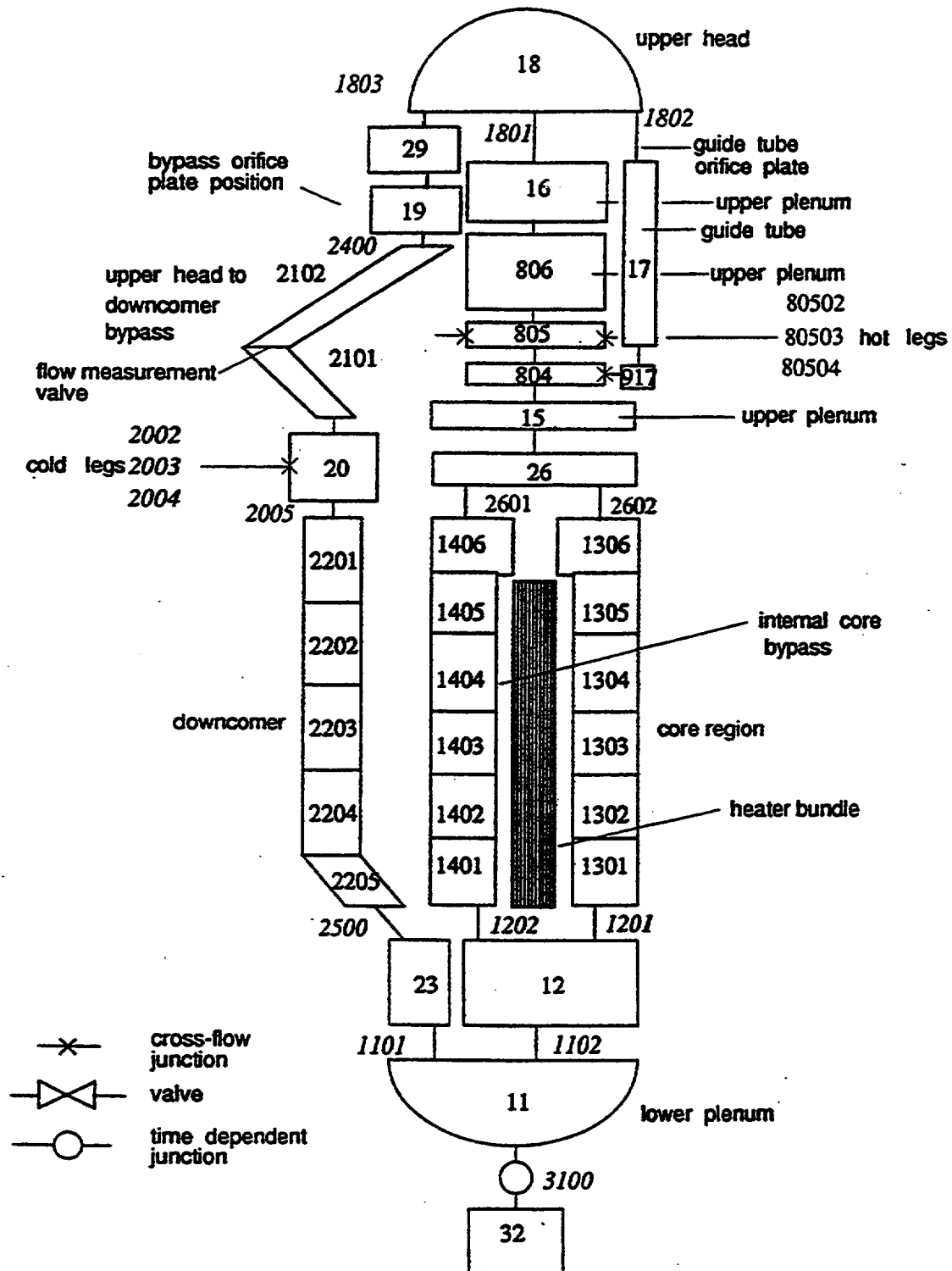

Figure 7 - RELAPS/MOD3.2 BETHSY loop 1 noding scheme

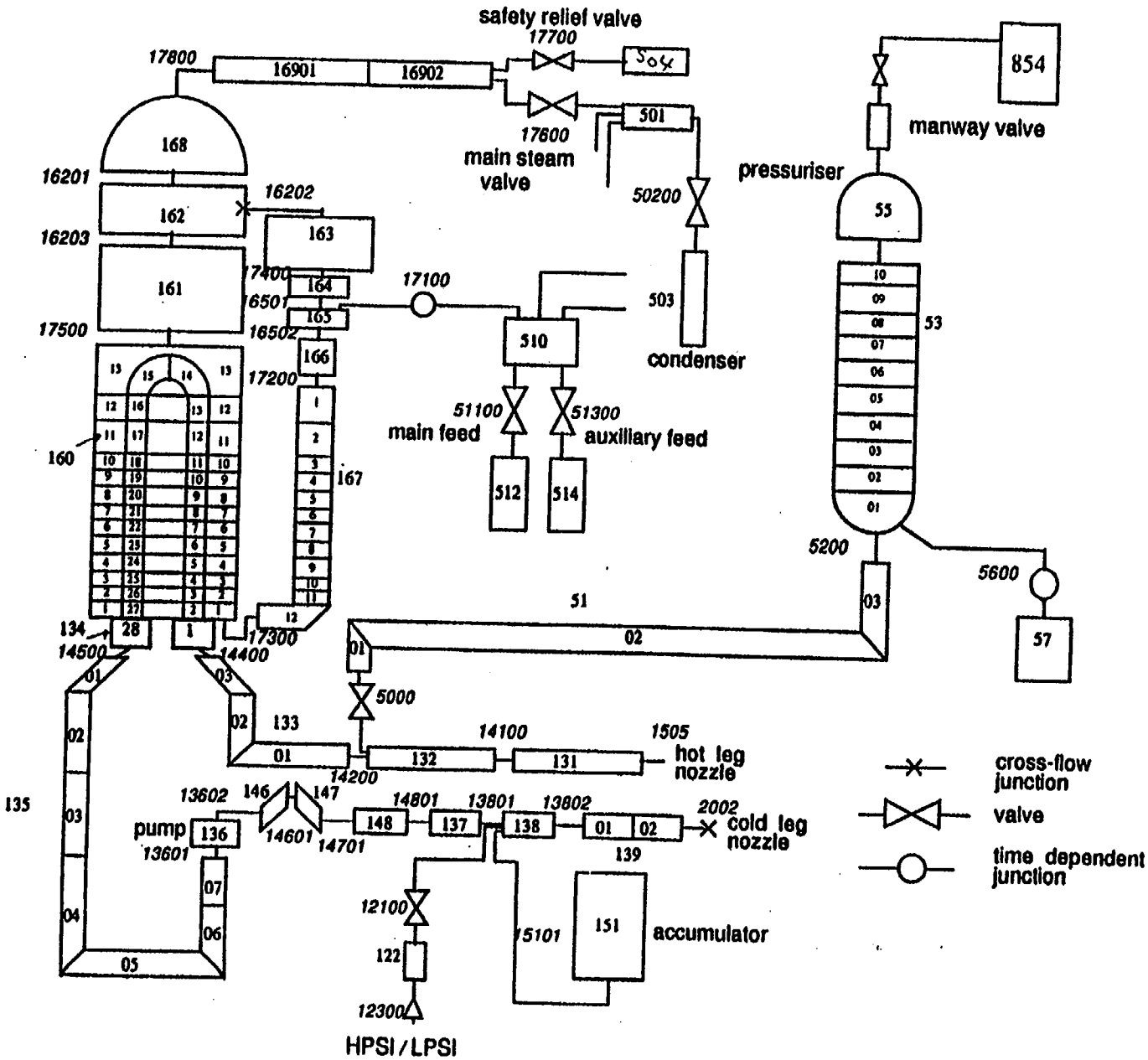
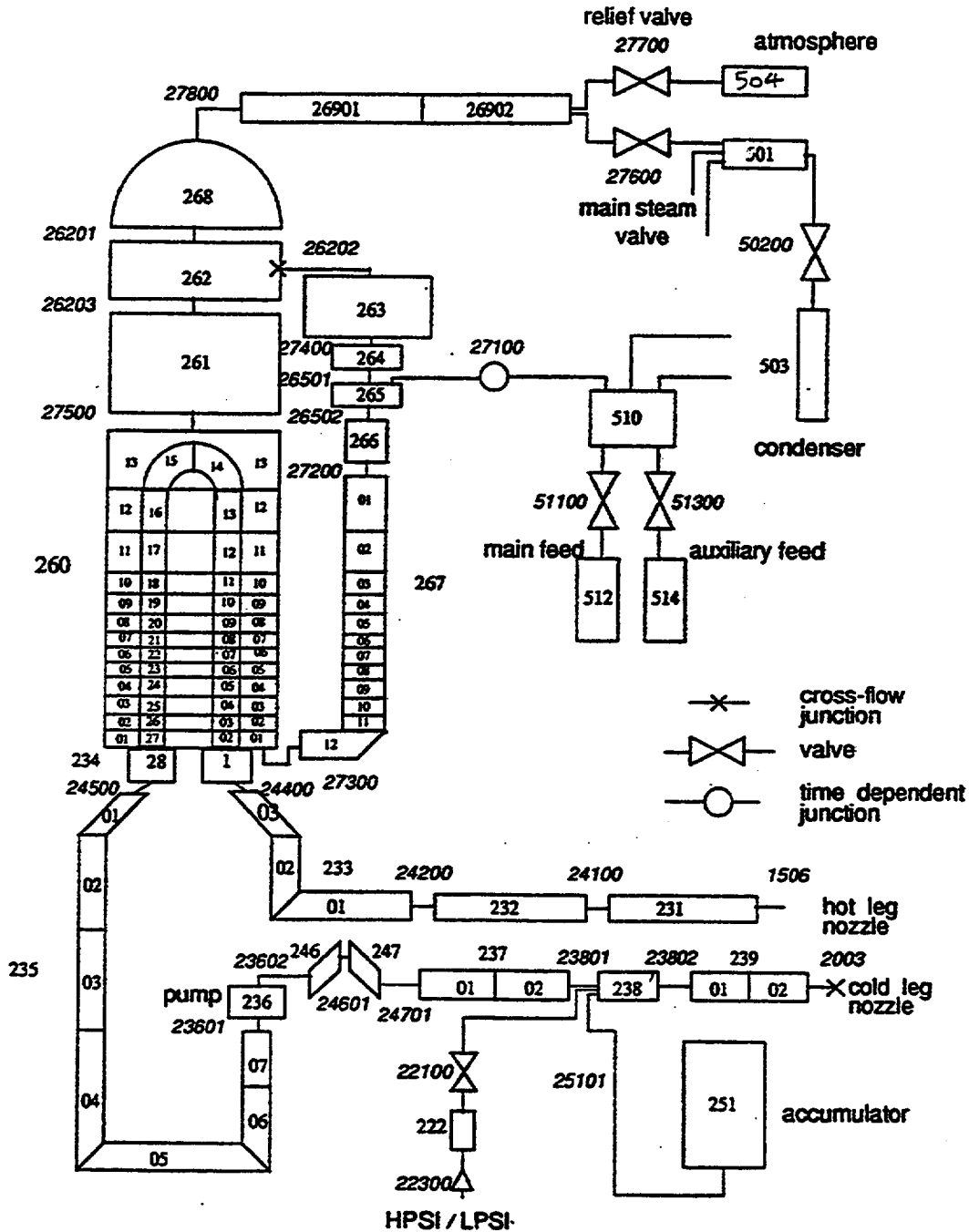
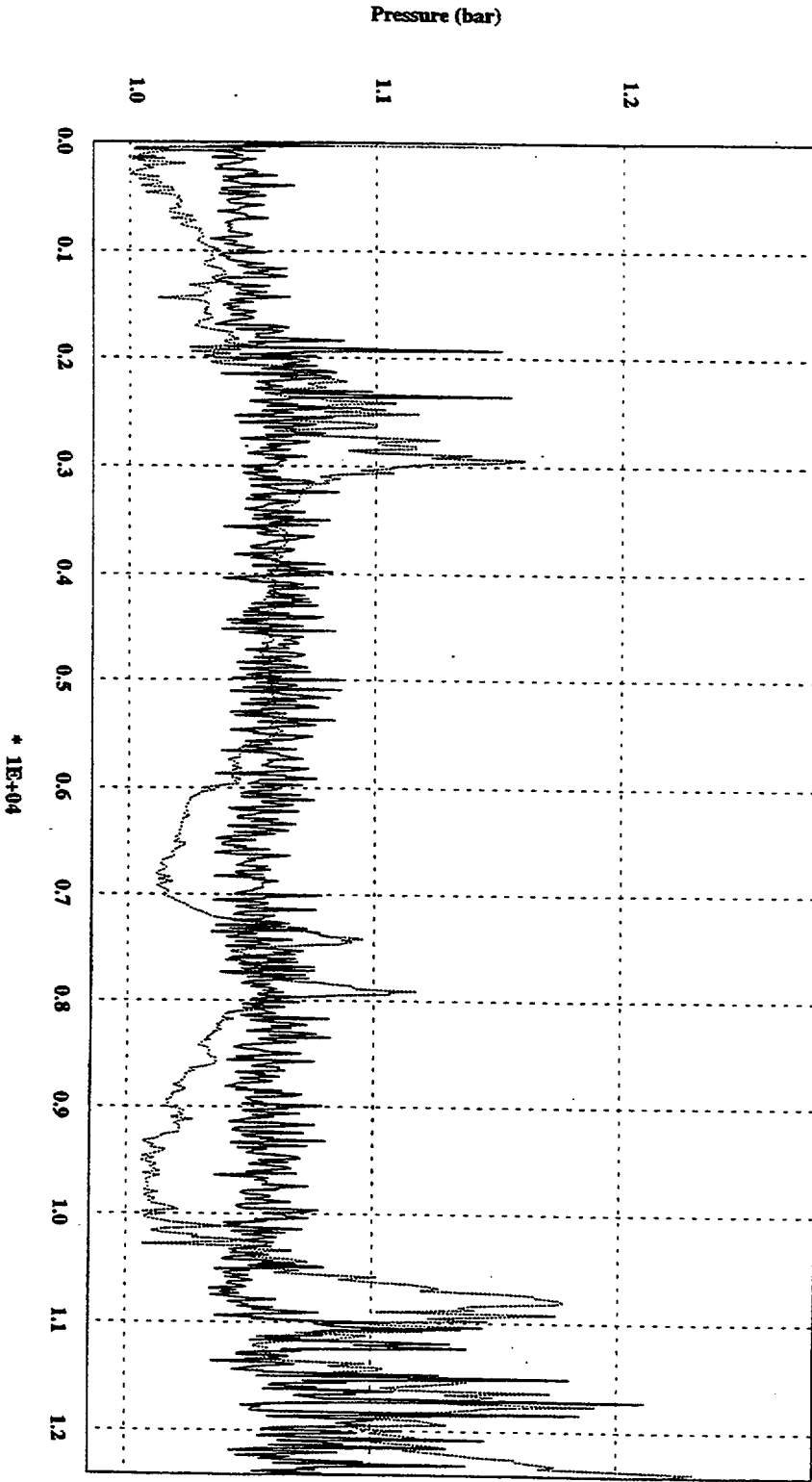

Figure 8 - RELAP5/MOD3.2 BETHSY loops 2 and 3 noding scheme



NNC - Thu Nov 27 16:51:28 GMT 1997 /usr/jamb/ublib/bethsy69a_calc/pl/POSTSCRIPT.01



BETHSY_P_ATM1

RELAPS:P5308

* 1E+04

BETHSY6.9a

Figure 9 - Pressuriser pressure

NNC - Thu Nov 27 16:52:30 GMT 1997 /usr/jack/bethsy/bethsy69a_calcd/POSTSCRIPT.02

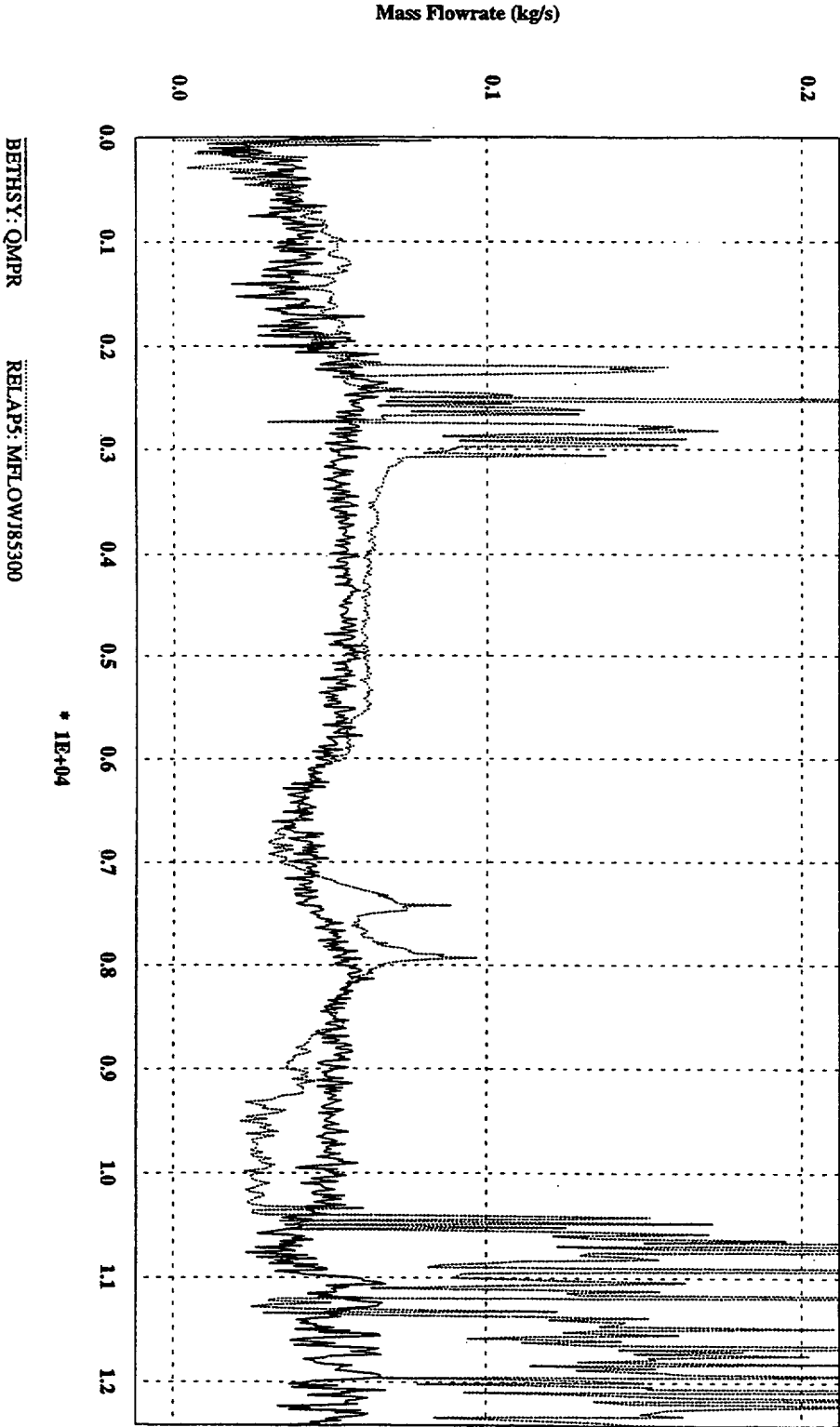

BETHSY6.9a

Figure 10 - Manway flowrate

Figure 11 - Cold leg 1 pressure

BETHSY6.9a

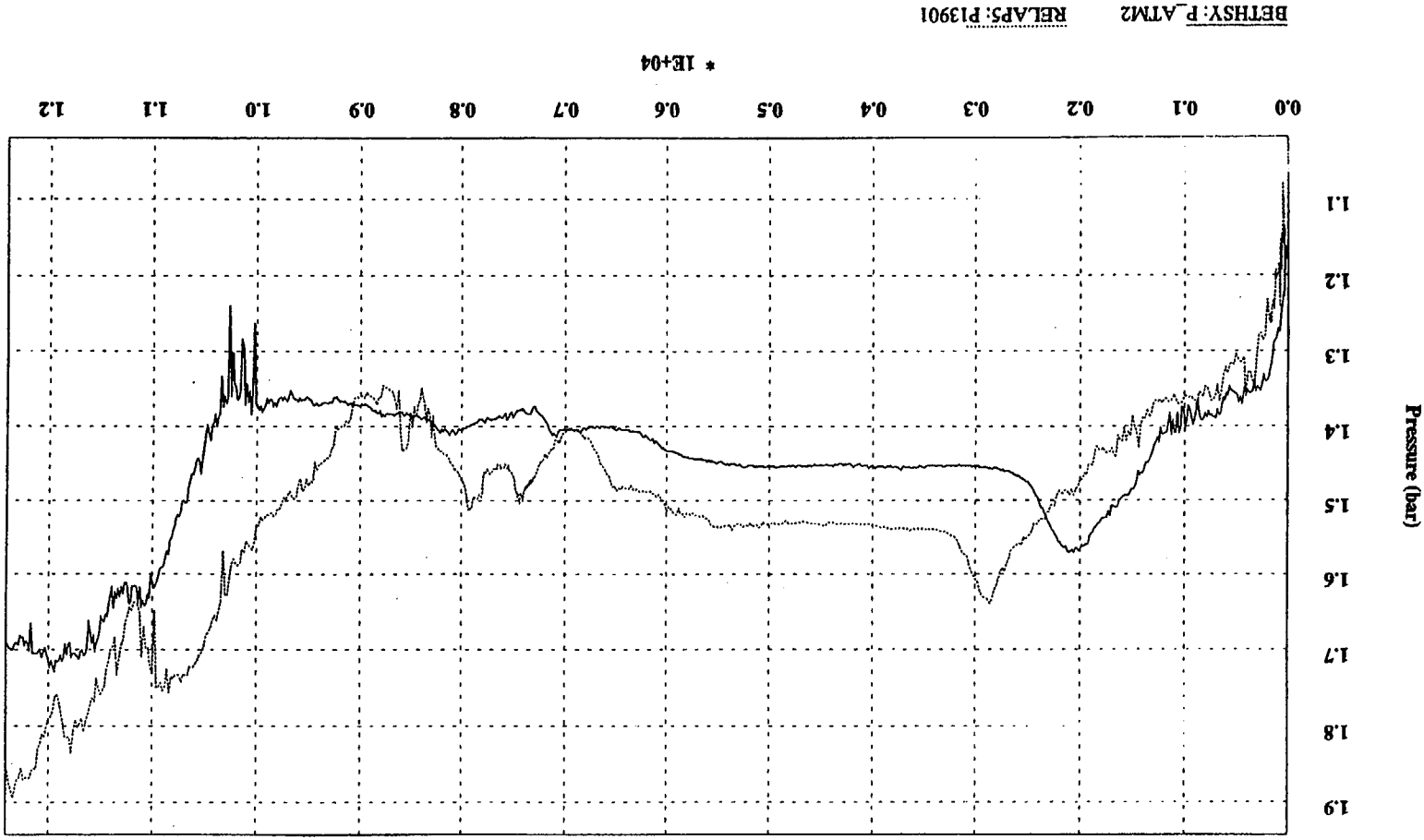

UNC - Thu Nov 27 16:52:32 GMT 1997 /usr/jkx/bethsy/bethsy6.9a_calc/p1/POSTSCRIPT.03

Figure 12 - AP across the pressuriser

BETHSY6.9a

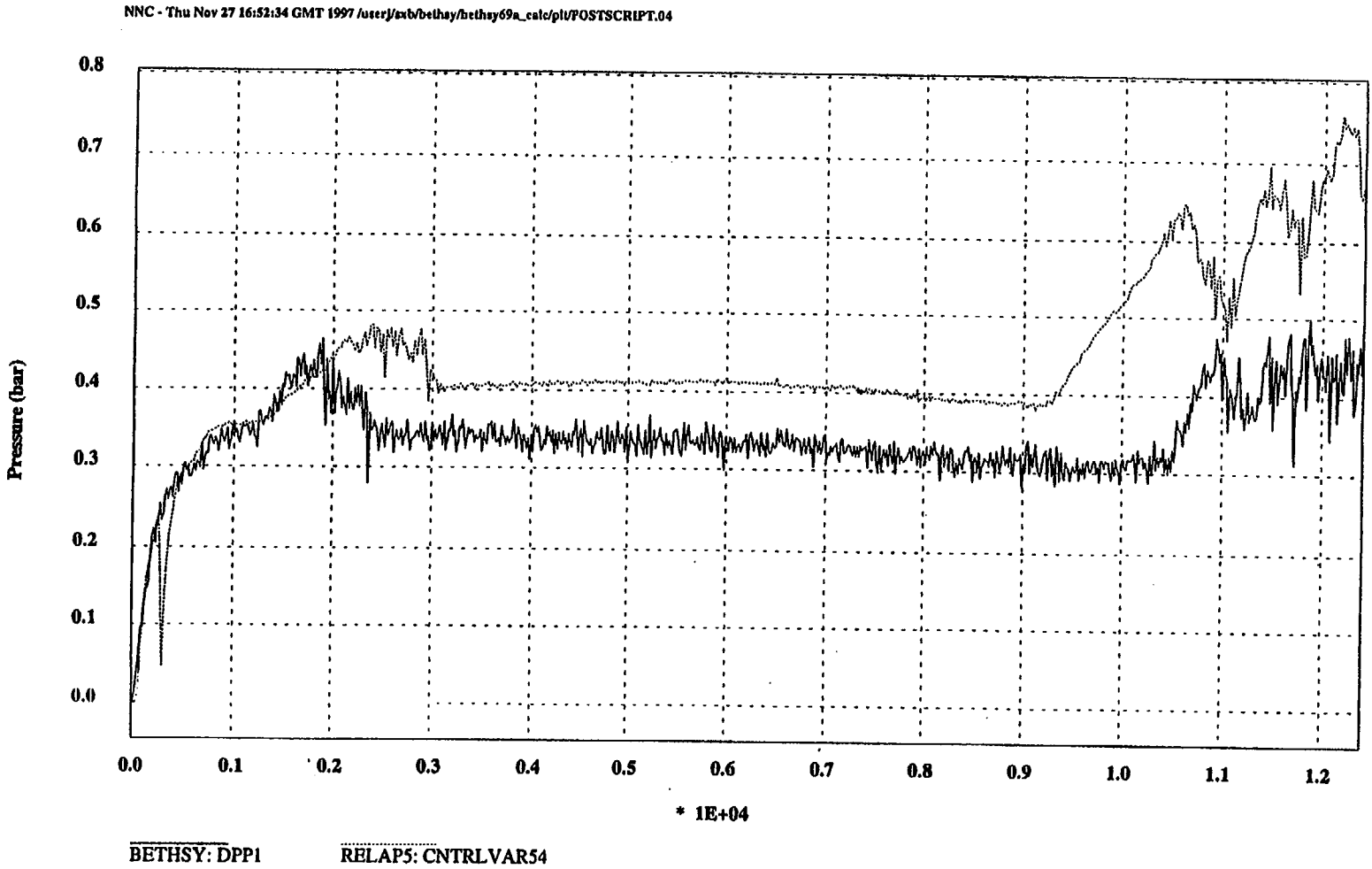
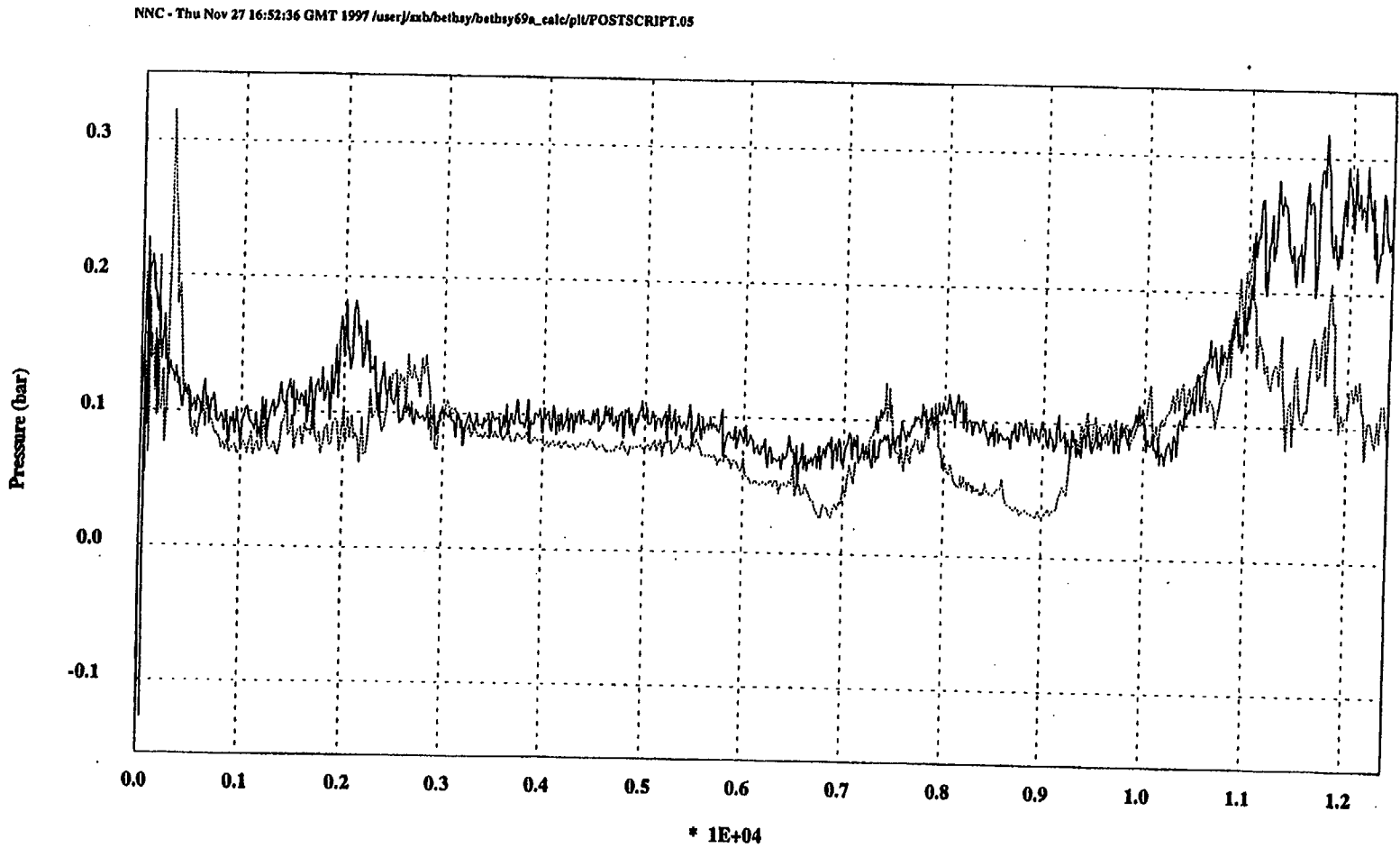

Figure 13 - AP across the surge line

BETHSY6.9a



BETHSY: DPP3

RBLAP5: CNTRLVAR56

Figure 14 - Integrated manway discharge

BETHSY6.9a

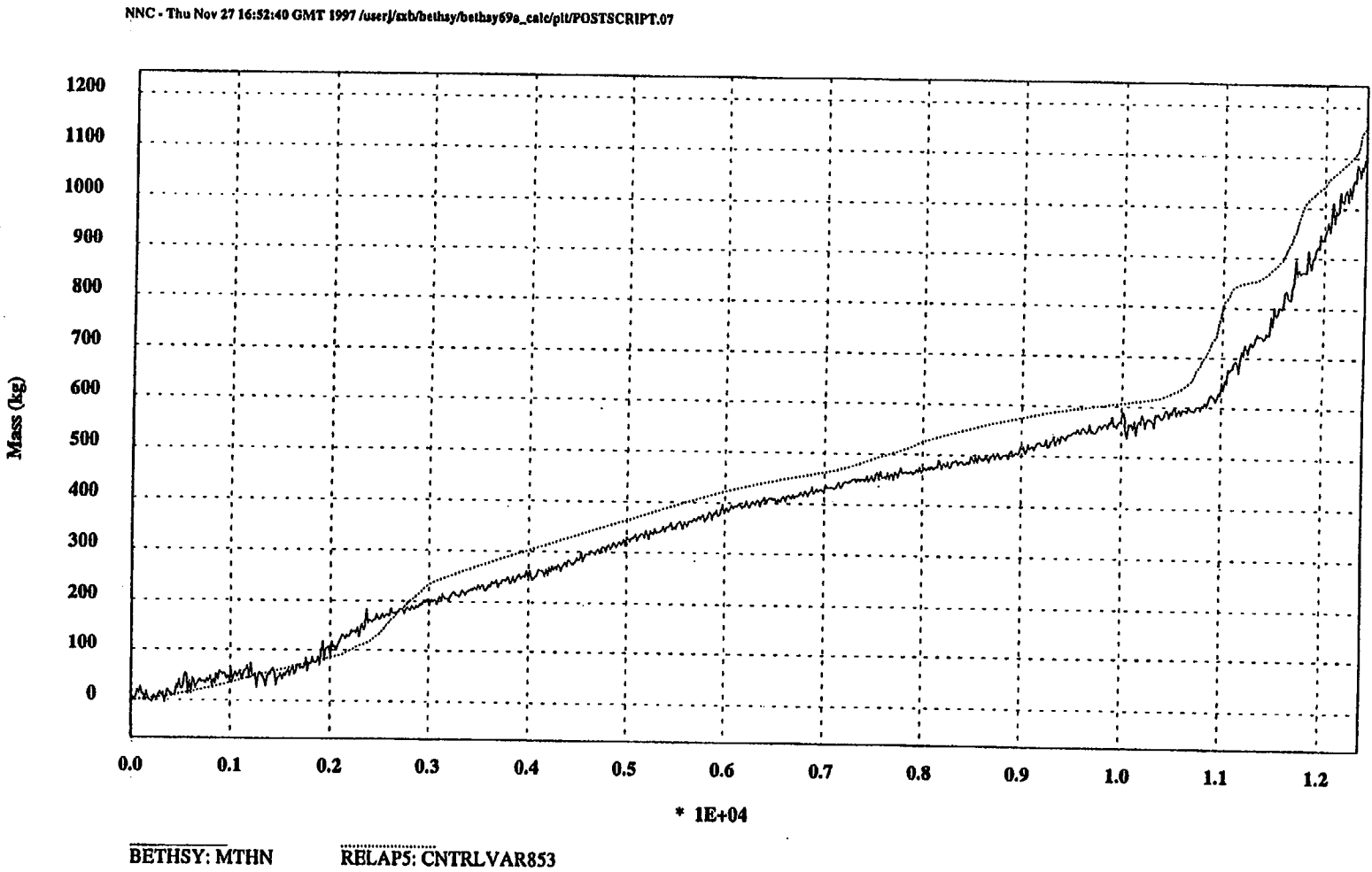
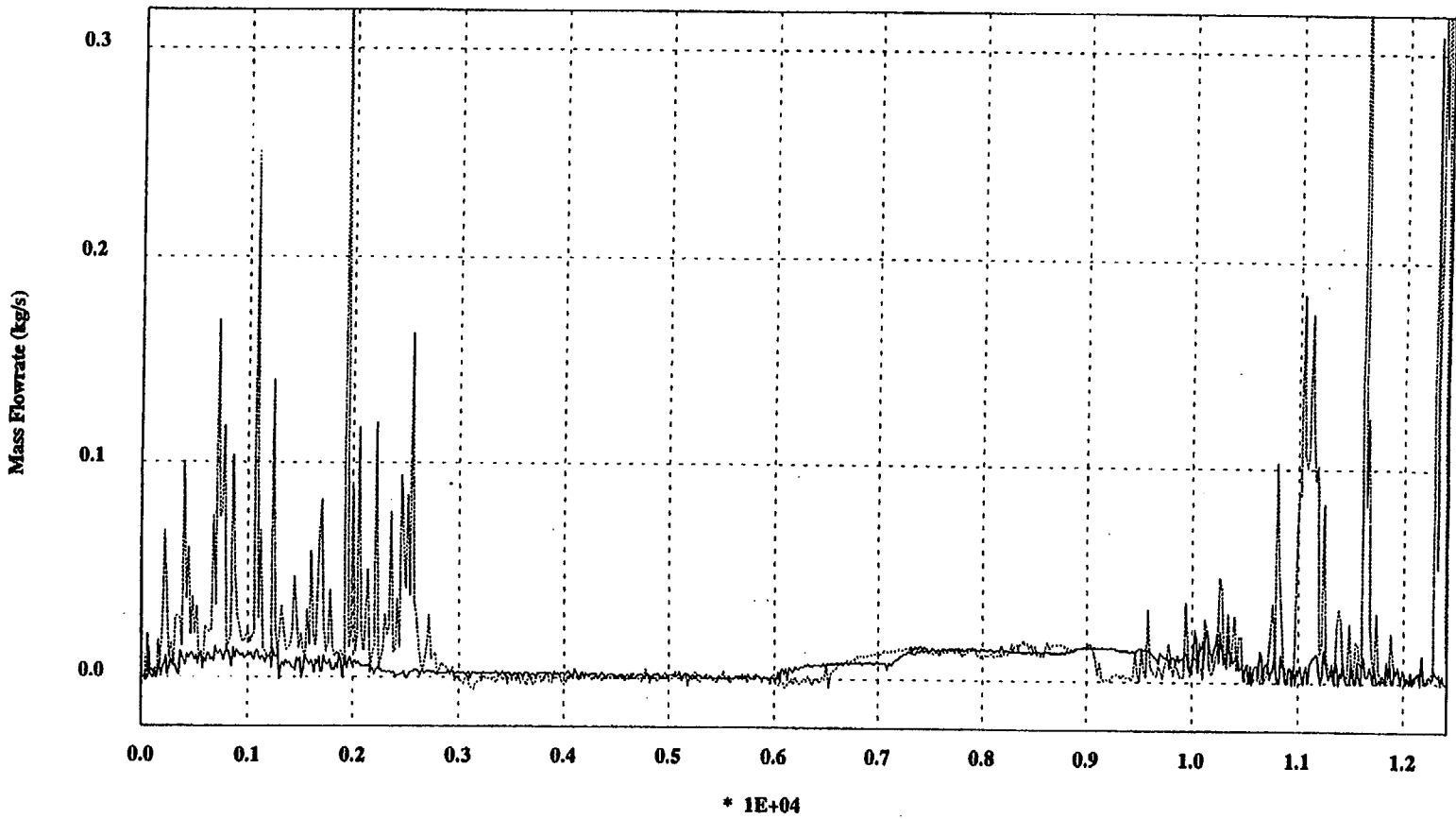

Figure 15 - Upper head bypass flowrate

BETHSY6.9a



NNC - Thu Nov 27 16:52:42 GMT 1997 /user/evb/bethsy/bethsy69a_calc/plu/POSTSCRIPT.08

BETHSY: QMBYPD RELAP5: MFLOWJ853

Figure 16 - AP across the guide tube

BETHSY6.9a

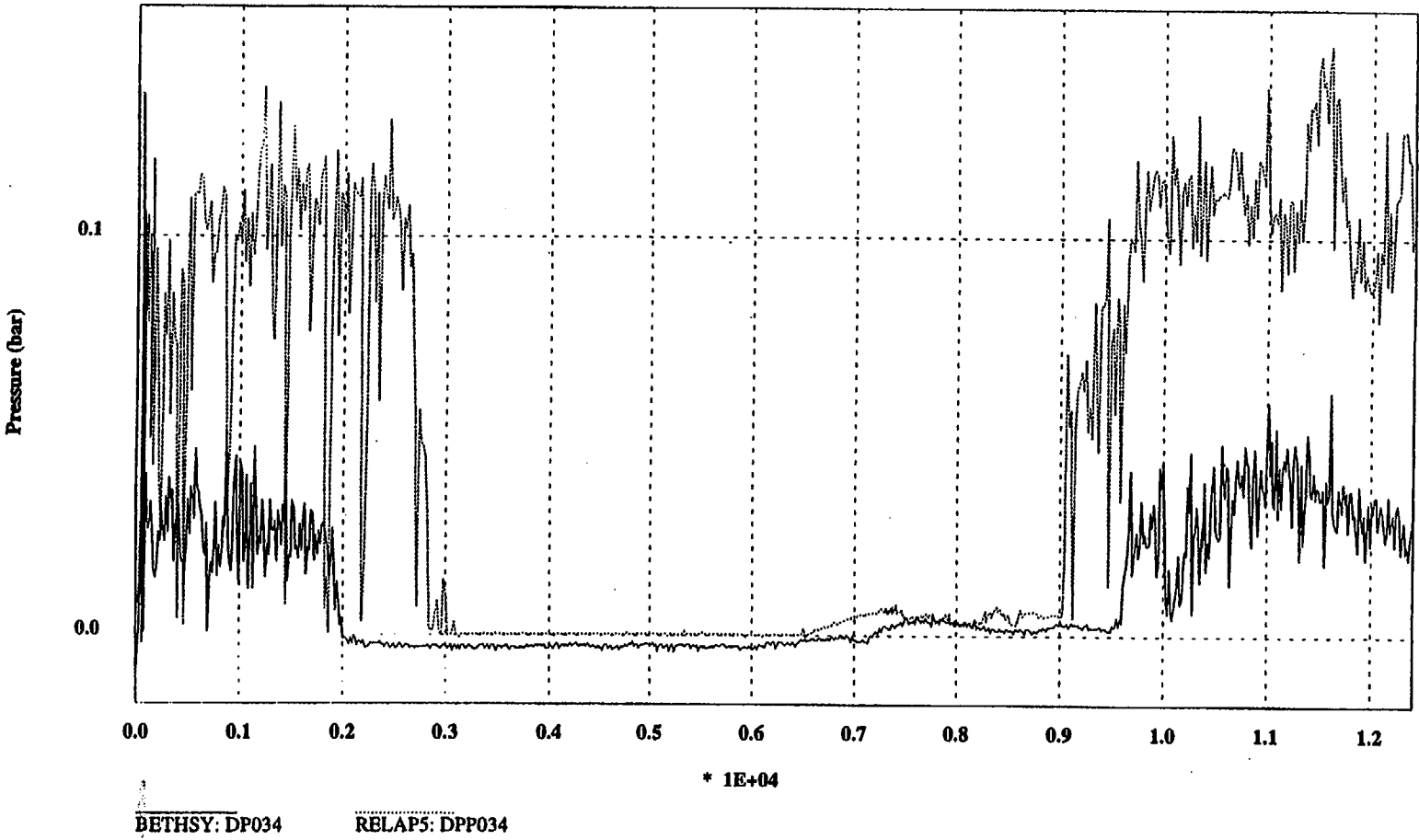

NNC - Thu Nov 27 16:52:44 GMT 1997 /user/mb/bethsy/bethsy69a_calc/plu/POSTSCRIPT.09

Figure 17 - Cold leg 1 void fraction

BETHSY6.9a

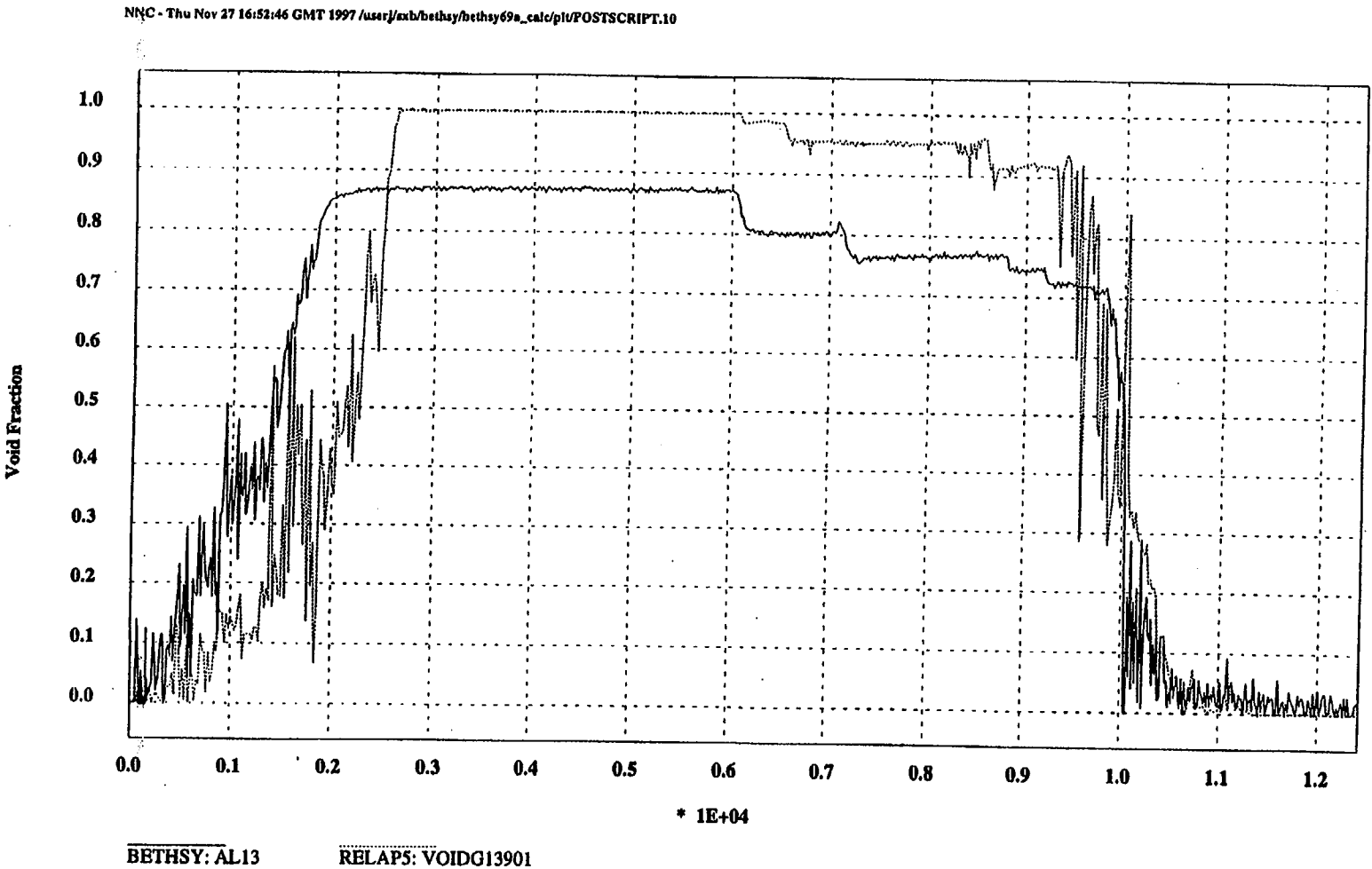

Figure 18 - Hot leg 1 void fraction

BETHSY6.9a

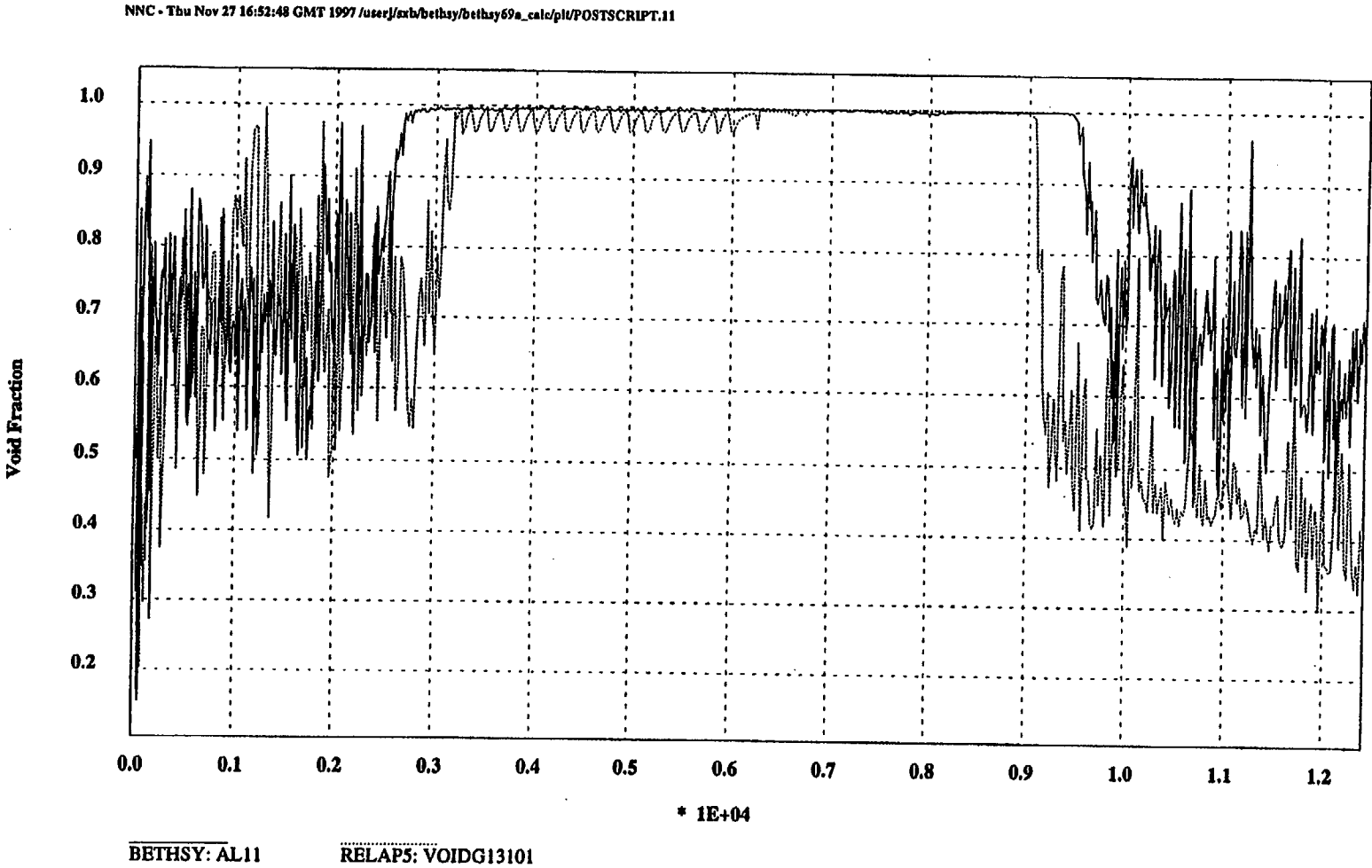

Figure 19 - Primary system mass inventory

BETHSY6.9a

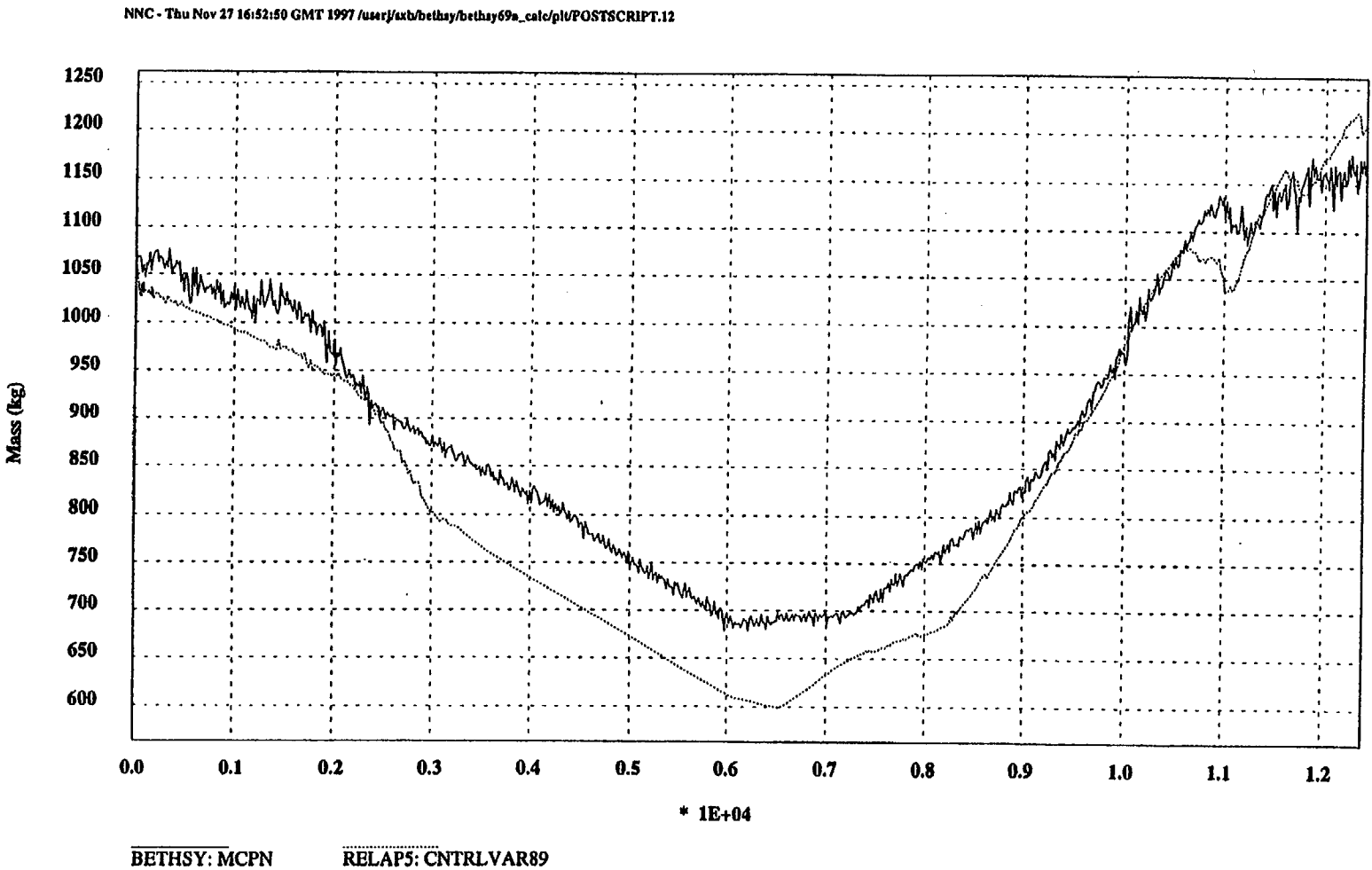

Figure 20 - Hottest rod maximum temperature

BETHSY6.9a

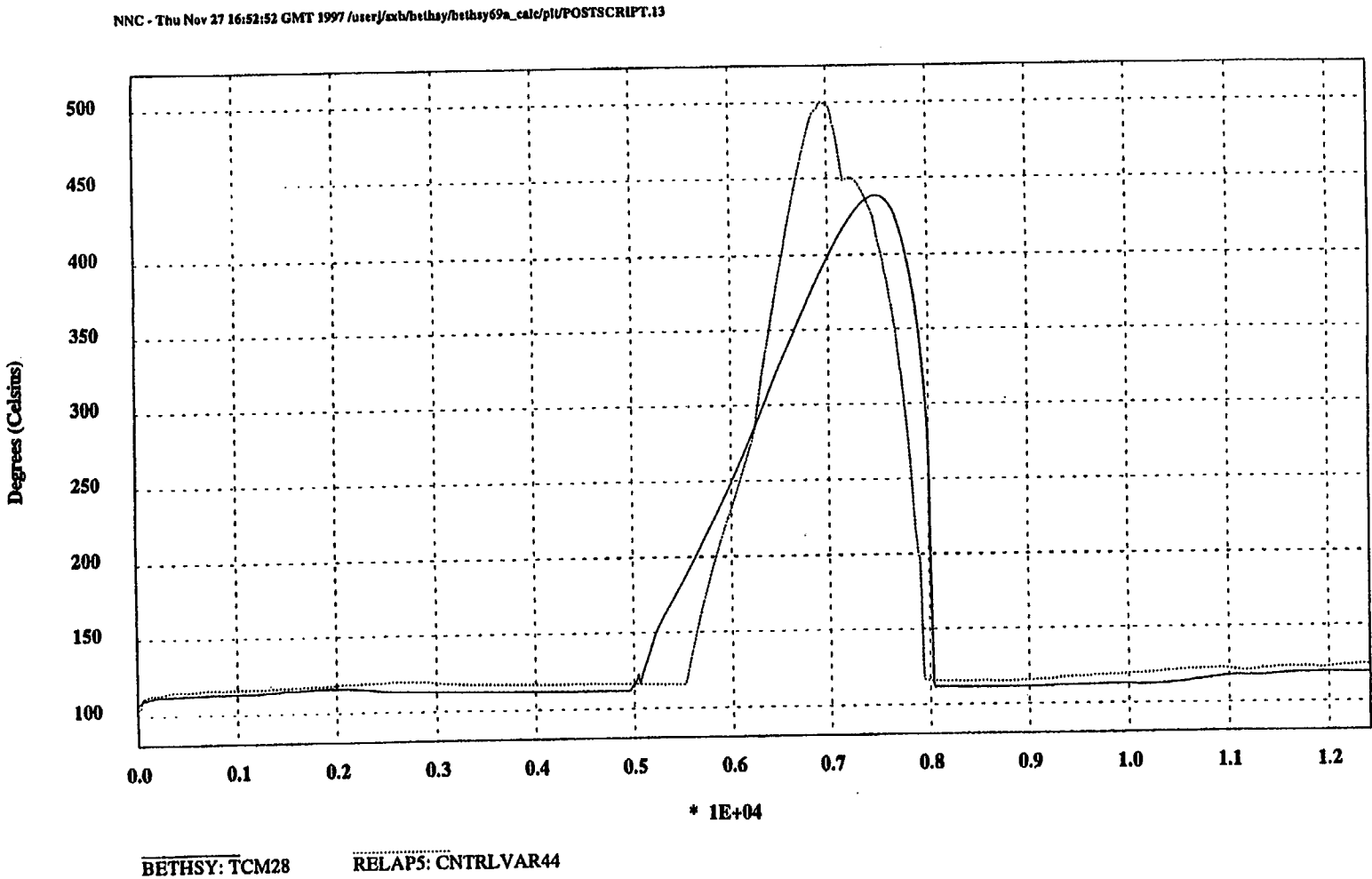

Figure 21 - Gravity and pumped injection flowrate

BETHSY6.9a

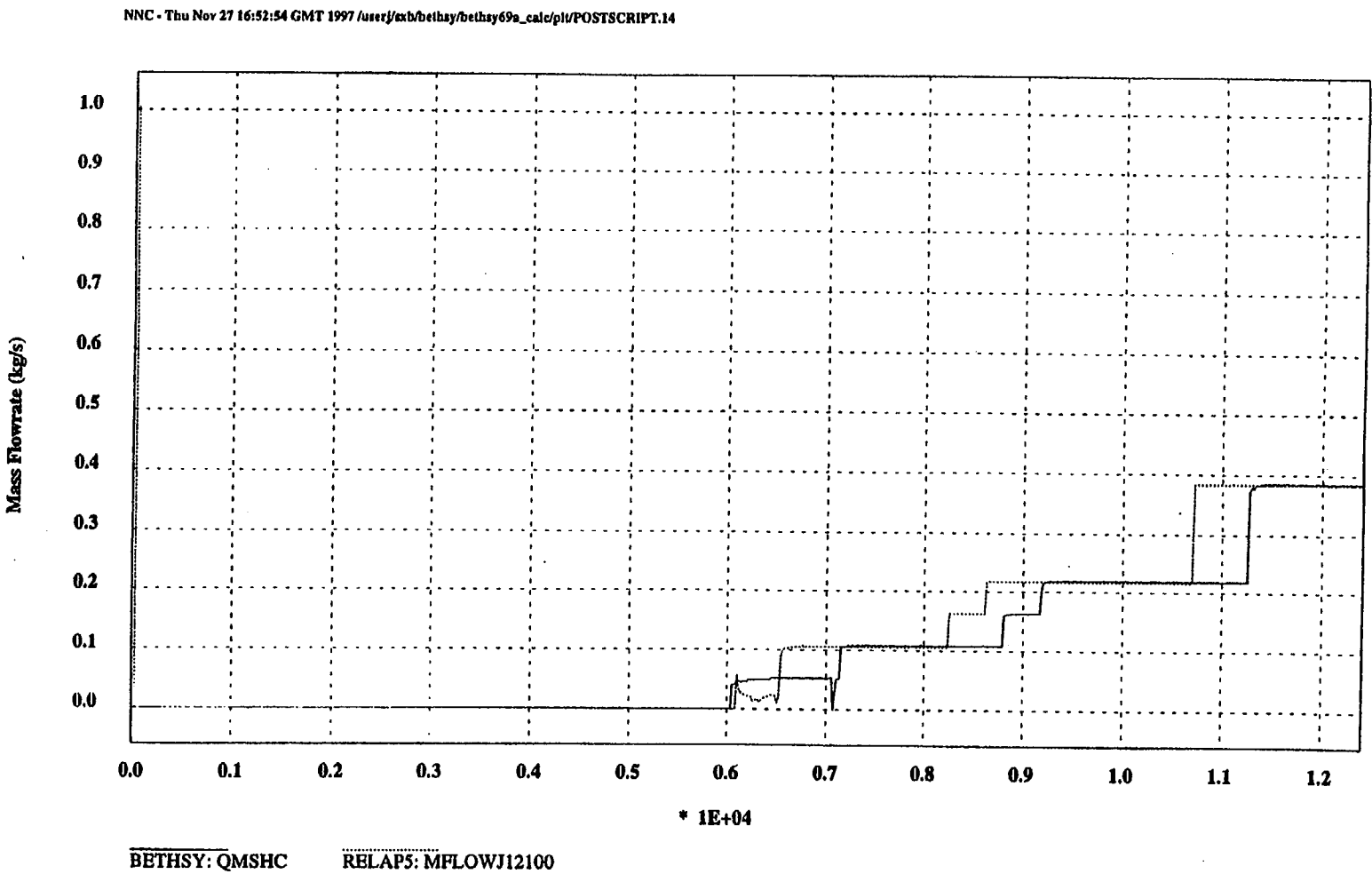
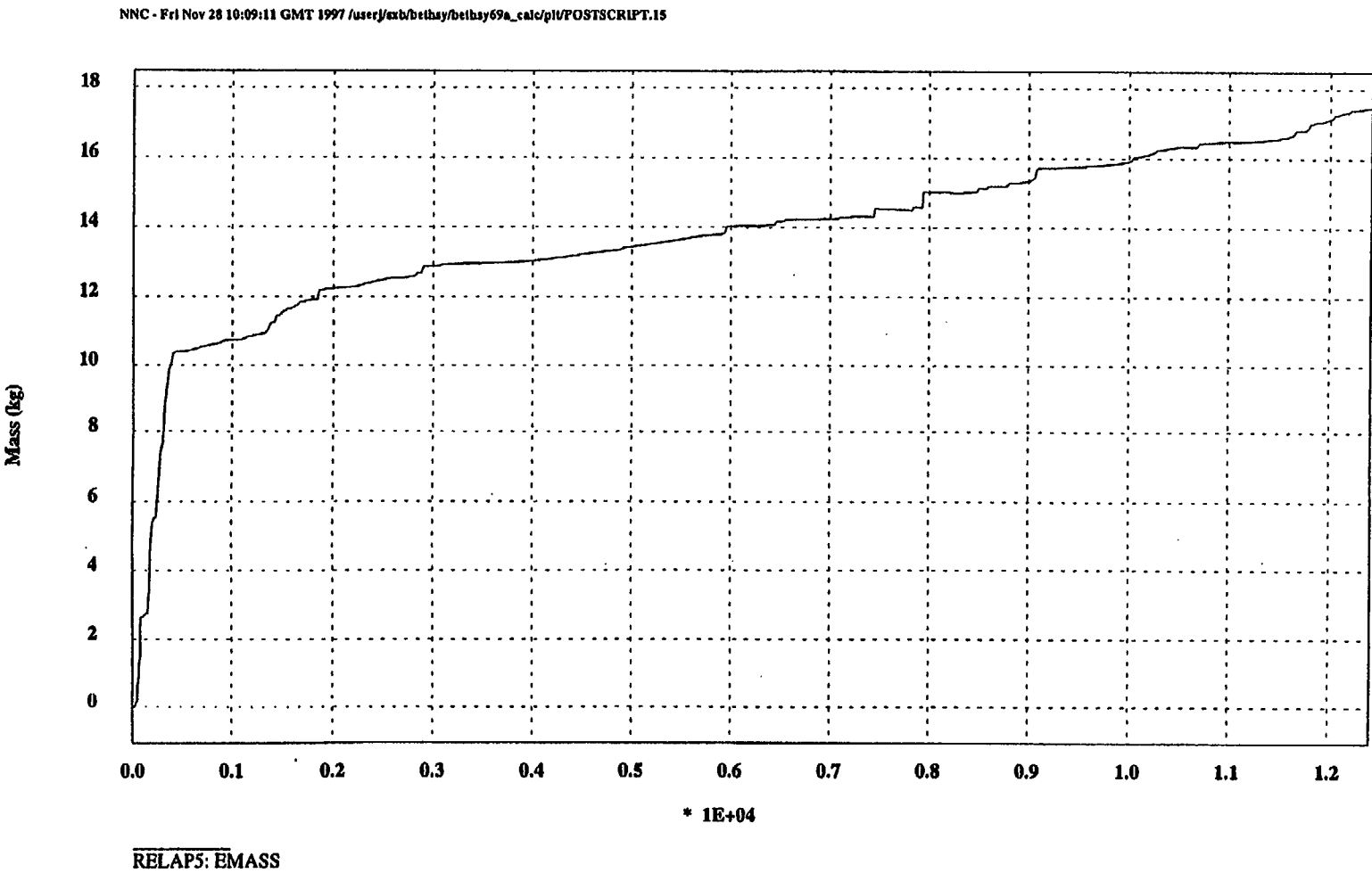

Figure 22 - RELAP5/MOD3.2 mass error

BETHSY6.9a



BIBLIOGRAPHIC DATA SHEET

(See instructions on the reverse)

1. REPORT NUMBER
(Assigned by NRC, Add Vol., Supp., Rev.,
and Addendum Numbers, if any.)

NUREG/IA-0188

2. TITLE AND SUBTITLE

RELAP5/MOD3 Validation Using BETHSY Test 6.9a

3. DATE REPORT PUBLISHED

MONTH	YEAR
August	2000

4. FIN OR GRANT NUMBER

5. AUTHOR(S)

S. Bouabdallah

6. TYPE OF REPORT

Technical

7. PERIOD COVERED *(Inclusive Dates)*

8. PERFORMING ORGANIZATION - NAME AND ADDRESS *(If NRC, provide Division, Office or Region, U.S. Nuclear Regulatory Commission, and mailing address; if contractor, provide name and mailing address.)*

NNV LTD Booths Hall
Chelford Road
Knutsford, Cheshire GB-WA16 8QZ
UNITED KINGDOM

9. SPONSORING ORGANIZATION - NAME AND ADDRESS *(If NRC, type "Same as above"; if contractor, provide NRC Division, Office or Region, U.S. Nuclear Regulatory Commission, and mailing address.)*

Division of Systems Analysis and Regulatory Effectiveness
Office of Nuclear Regulatory Research
U.S. Nuclear Regulatory Commission
Washington, DC 20555-0001

10. SUPPLEMENTARY NOTES

11. ABSTRACT *(200 words or less)*

This report provides the results of a RELAP5/MOD3.2 calculation of Test 6.9a which was carried out on the BETHSY facility. The purpose of the calculation is to provide validation evidence for the use of RELAP5/MOD3.2 for application to faults at Sizewell B which can occur when the plant is in Modes 5 and 6 (and including the use of nozzle dams).

12. KEY WORDS/DESCRIPTORS *(List words or phrases that will assist researchers in locating the report.)*

RELAP5/MOD3
BETHSY Test 6.9a

13. AVAILABILITY STATEMENT

unlimited

14. SECURITY CLASSIFICATION

(This Page)

unclassified

(This Report)

unclassified

15. NUMBER OF PAGES

16. PRICE

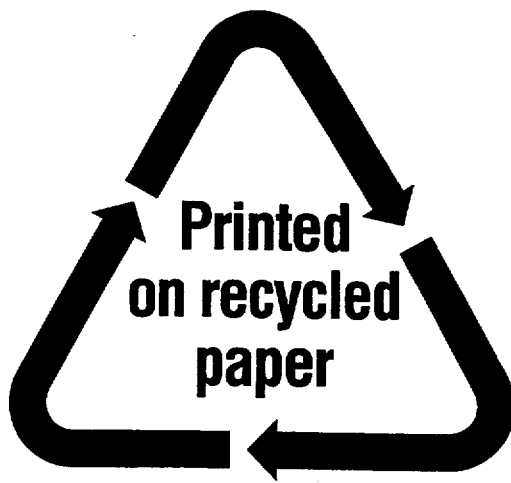

Federal Recycling Program

**UNITED STATES
NUCLEAR REGULATORY COMMISSION**
WASHINGTON, D.C. 20555-0001

