OFFICE OF ENFORCEMENT ANNUAL REPORT

Fiscal Year 1999

U.S. Nuclear Regulatory Commission

- CONTENTS -

Contents i
Abstract v
Overview of NRC Enforcement Program vii
Office of Enforcement ix

1. Enforcement Policy Changes 1

 A. December 24, 1998: Fuel Cycle Facilities Civil Penalties and NOEDs 1
 B. January 6, 1999: Discretion Involving Natural Events 1
 C. February 9, 1999: Revised Treatment of Severity Level IV Violations at Power Plants 1
 D. March 9, 1999: Interim Policy for Generally Licensed Devices
 Containing Byproduct Material 1
 E. May 19, 1999: Examples of Violations Involving Operators' Licenses 1
 F. July 30, 1999: Interim Policy Regarding Enforcement Discretion for
 Nuclear Power Plants During the Year 2000 Transition 2
 G. August 9, 1999: Interim Enforcement Policy for Use During the
 NRC Power Reactor Oversight Process Pilot Plant Study 2

2. Implementation, Staff Guidance, & Initiatives 2

 A. Enforcement Guidance Memoranda (EGMs) 2
 B. Enforcement Training 3
 C. Enforcement Action Tracking System (EATS) Upgrade 3
 E. Enforcement Information on the Internet 3

3. Escalated Enforcement and Administrative Items 4

 A. Escalated Notices of Violation (Without Civil Penalties) 5
 B. Civil Penalty Actions 6
 C. Orders 6
 D. Demands for Information 6
 E. Summary of Significant Actions 6

F. Escalated Enforcement Trends 10

4. Cases Involving Exercise of Discretion 14

5. Actions Against Individuals & Other Non-Licensed Persons 15

 A. Actions Against Licensed Individuals 15

 B. Actions Against Non-Licensed Individuals 15

 C. Actions Against Non-Licensed Persons Other Than Individuals 15

6. Cases Involving Discrimination 16

7. Hearing Activities 16

8. 10 CFR 2.206 Petitions 16

9. Withdrawn and Modified Enforcement Actions 16

- TABLES -

1. Escalated Enforcement Items and Demands for Information 17

2. Escalated Enforcement Items by Type of Licensee, Vendor, or Individual 19

3. Civil Penalty Information 21

4. Civil Penalty Ranges 23

5. 2-Year Escalated Item History for Reactor Sites 25

- FIGURES -

1. Escalated Enforcement Trends 10

2. Escalated Enforcement Trends - Reactors 11

3. Escalated Enforcement Trends - Materials 11

4. Escalated Enforcement Trends - Individuals 11

5. 2-Year Escalated Enforcement Review (Operating Reactors) 12

6. Civil Penalty Trends (Operating Reactors) 13

7. Analysis of Escalated Items Processed Under
Civil Penalty Assessment Process 27

8. Analysis of Escalated Reactor Items Processed Under
Civil Penalty Assessment Process 29

9. Analysis of Escalated Materials Items Processed Under
Civil Penalty Assessment Process 31

10. Civil Penalty Process - Path A 33

11. Civil Penalty Process - Path B 35

12. Civil Penalty Process - Path C 37

13. Civil Penalty Process - Path D 39

14. Civil Penalty Process - Path E 41

15. Civil Penalty Process - Path F 43

16. Civil Penalty Process - Path G 45

17. Civil Penalty Process - Path H 47

18. Civil Penalty Process - Path I 49

19. Civil Penalty Process - Path J 51

20. Civil Penalty Process - Path K 53

21. Civil Penalty Process - Path L 55

- APPENDICES -

A. Summary of Escalated Notices of Violation (Without Civil Penalties) 57

B. Summary of Proposed Civil Penalties 69

C. Summary of Orders 75

D. Summary of Demands for Information 77

E. Summary of Cases Involving Exercise of Discretion 79

F. Summary of Actions Against Licensed Individuals 91

G. Summary of Actions Against Non-Licensed Individuals 93

H. Summary of Actions Against Non-Licensed Persons Other Than Individuals 99

I. Summary of Cases Involving Discrimination 101

J. Summary of Hearing Activity 105

K. Summary of 10 CFR 2.206 Activity 107

L. Summary of Withdrawn Enforcement Actions 109

Abstract

This annual report of the U.S. Nuclear Regulatory Commission's Office of Enforcement describes enforcement activities occurring during fiscal year 1999 (October 1, 1998 through September 30, 1999). The report addresses significant policy changes, highlights significant enforcement actions, and includes summaries of cases involving exercise of discretion, discrimination and actions involving individuals. It also addresses implementation, staff guidance, and initiatives for the agency's enforcement program. A variety of statistical tables and figures are also included.

PAGE INTENTIONALLY LEFT BLANK

Overview of NRC Enforcement Program

The Commission has developed an enforcement program and Enforcement Policy to support the NRC's overall safety mission in protecting the public and the environment. Consistent with that purpose, enforcement action should be used as a deterrent to emphasize the importance of compliance with regulatory requirements, and to encourage prompt identification and prompt, comprehensive correction of violations.

During the past fiscal year, the enforcement program has begun a process of significant change. This process reflects the NRC's extensive efforts to address industry and other stakeholder concerns and demonstrates the agency's commitment to more risk-informed, performance-based regulatory and enforcement programs. The agency is improving the process for assessing the significance of violations by making better use of risk information, eliminating the use of "regulatory significance," and stopping the practice of aggregating multiple low significance violations into escalated enforcement actions. In February 1999, the Commission issued a Policy revision on the treatment of low risk significant violations at operating reactors placing more emphasis on licensees addressing concerns within their own corrective action programs. On August 9, 1999, the Commission published an interim Enforcement Policy for use during the reactor oversight process pilot plant study. All of these changes are intended to be consistent with the agency's performance goals of maintaining safety; reducing unnecessary burden; making NRC activities and decisions more effective, efficient, and realistic; and increasing public confidence.

Violations are identified through inspections and investigations. All violations are subject to civil enforcement action and may also be subject to criminal prosecution. After an apparent violation is identified, it is assessed in accordance with the Commission's Enforcement Policy. The Policy is published as NUREG-1600, "General Statement of Policy and Procedure for NRC Enforcement Actions," to foster its widespread dissemination. As a living policy statement, revisions are noticed in the *Federal Register*. The NRC's Office of Enforcement maintains the current policy statement on its homepage on the Internet at www.nrc.gov/OE/. Because it is a policy statement and not a regulation, the Commission may deviate from the Enforcement Policy as appropriate under the circumstances of a particular case.

There are three primary enforcement sanctions available: Notices of Violation, civil penalties, and orders. A Notice of Violation (NOV) identifies a requirement and how it was violated, formalizes a violation pursuant to 10 CFR 2.201, and normally requires a written response. A civil penalty is a monetary fine issued under authority of Section 234 of the Atomic Energy Act (AEA) or Section 206 of the Energy Reorganization Act (ERA). Section 234 of the AEA provides for penalties of up to \$100,000 per violation per day; but that amount has been adjusted by the Debt Collection Improvement Act of 1996 to be \$110,000. The Commission's order issuing authority under Section 161 of the AEA is broad and extends to any area of licensed activity that affects the public health and safety. Orders modify, suspend, or revoke licenses or require specific actions by licensees or persons. NOV's and civil penalties are issued based on violations. Orders may be issued for violations, or in the absence of a violation, because of a public health or safety issue.

The first step in the enforcement process is assessing the significance of violations and assigning commensurate severity levels. Severity Levels range from Severity Level I, for the most significant violations, to Severity Level IV for those of more than minor concern. Minor violations are not subject to formal enforcement action.

A predecisional enforcement conference may be conducted with a licensee before making an enforcement decision if escalated enforcement action (i.e., Severity Level I, II, or III violations, civil penalties or orders) appears to be warranted, and if the NRC concludes that it is necessary or the licensee requests it. If the NRC

concludes that a conference is not necessary, it may provide a licensee with an opportunity to respond to the apparent violations before making an enforcement decision. The purpose of the conference is to obtain information that will assist the NRC in determining the appropriate enforcement action, such as: (1) a common understanding of facts, root causes and missed opportunities associated with the apparent violations, (2) a common understanding of corrective action taken or planned, and (3) a common understanding of the significance of issues and the need for lasting comprehensive corrective action. The decision to hold a conference does not mean that the agency has determined that a violation has occurred or that enforcement action will be taken. In accordance with the Enforcement Policy, conferences are normally open to public observation.

Civil penalties are considered for Severity Level III violations and are normally assessed for Severity Level I and II violations and knowing and conscious violations of the reporting requirements of Section 206 of the Energy Reorganization Act.

The NRC imposes different levels of civil penalties based on a combination of the type of licensed activity, the type of licensee, the severity level of the violation, and (1) whether the licensee has had any previous escalated enforcement action (regardless of the activity area) during the past 2 years or past 2 inspections, whichever is longer; (2) whether the licensee should be given credit for actions related to identification; (3) whether the licensee's corrective actions are prompt and comprehensive; and (4) whether, in view of all the circumstances, the matter in question requires the exercise of discretion. Although each of these decisional points may have several associated considerations for any given case, the outcome of the assessment process for each violation or problem, absent the exercise of discretion, is limited to one of the following three results: no civil penalty, a base civil penalty, or twice the base civil penalty.

If a civil penalty is to be proposed, a written Notice of Violation and Proposed Imposition of Civil Penalty is issued and the licensee has 30 days to respond in writing, by either paying the penalty or contesting it. The NRC considers the response, and if the penalty is contested, may either mitigate the penalty or impose it by order. Thereafter, the licensee may pay the civil penalty or request a hearing.

In addition to civil penalties, orders may be used to modify, suspend, or revoke licenses. Orders may require additional corrective actions, such as removing specified individuals from licensed activities or requiring additional controls or outside audits. Persons adversely affected by orders that modify, suspend, or revoke a license, or that take other action may request a hearing.

The NRC issues a press release with a proposed civil penalty or order. All orders are published in the *Federal Register*.

Fiscal Year 1999 Highlights:

- ▶ seven Enforcement Policy revisions
- ▶ 73 escalated Notices of Violation without civil penalties
- ▶ 24 proposed civil penalties (\$1,062,600)
- ▶ 17 orders
- ▶ 5 orders imposing civil penalties

For more information on the NRC's enforcement program, visit the Office of Enforcement's Web site at www.nrc.gov/OE/.

Office of Enforcement

The Office of Enforcement (OE) exercises oversight of NRC enforcement programs, provides programmatic and implementation direction to regional and headquarters offices conducting or involved in enforcement activities, and ensures that regional enforcement programs are adequately carried out.

The Office of Enforcement reports to the Executive Director for Operations (EDO) through the Deputy Executive Director for Reactor Programs and coordinates enforcement actions involving materials licensees with the Deputy Executive Director for Materials, Research and State Programs.

The Office of Enforcement has 16 full-time employees (FTEs) assigned for headquarters activities and 12 FTEs assigned for regional activities (although these FTEs report to the Regional Administrators).

1. Enforcement Policy Changes

This section describes the seven revisions to the Enforcement Policy that were made during fiscal year 1999.

A. December 24, 1998: Fuel Cycle Facilities Civil Penalties and NOEDs

On December 24, 1998, the Commission published a revision to the Enforcement Policy to increase the base civil penalties for fuel cycle facilities authorized to possess certain quantities of special nuclear material and to authorize issuance of Notices of Enforcement Discretion to Gaseous Diffusion Plants.

B. January 6, 1999: Discretion Involving Natural Events

On January 6, 1999, the Commission published a revision to the Enforcement Policy to address enforcement discretion in cases involving natural events, such as severe weather conditions.

C. February 9, 1999: Revised Treatment of Severity Level IV Violations at Power Plants

On February 9, 1999, the Commission published a revision to the Enforcement Policy by adding Appendix C to the policy. This amendment revised the treatment of Severity Level IV violations at power reactors by: (1) expanding the use of Non-Cited Violations (NCVs) to include Severity Level IV violations identified by the NRC; (2) providing that except under limited, defined circumstances, individual Severity Level IV violations normally will result in NCVs and not in Notices of Violation (NOVs); and (3) permitting NRC closure of most Severity Level IV violations based on their having been entered into a licensee's corrective action program.

D. March 9, 1999: Interim Policy for Generally Licensed Devices Containing Byproduct Material

On March 9, 1999, the Commission published a revision to the Enforcement Policy by adding Appendix D to the policy. This amendment describes the interim enforcement policy that the NRC will follow to exercise enforcement discretion for certain violations of requirements in 10 CFR Part 31 for generally licensed devices containing byproduct material. It addresses violations that persons licensed pursuant to 10 CFR 31.5 identify and correct now, as well as during the initial cycle of the notice and response program contemplated by the proposed new requirements published in the Federal Register on December 2, 1998 (63 FR 66492), entitled "Requirements for Those Who Possess Certain Industrial Devices Containing Byproduct Material to Provide Requested Information".

E. May 19, 1999: Examples of Violations Involving Operators' Licenses

On May 19, 1999, the Commission published a revision to the Enforcement Policy to conform to the amendments to the regulations that govern operators' licenses published in the *Federal Register* as a separate action. Those amendments allow nuclear power facility licensees to prepare, proctor, and grade the written examinations and prepare the operating tests that the NRC uses to evaluate the competence of individuals applying for operator licenses at the facility licensees' plants. Moreover, the amendment requires facility licensees that elect to prepare their own examinations to establish, implement, and maintain procedures to control examination security and integrity, and it clarifies the regulations to

ensure that applicants, licensees, and facility licensees understand what it means to compromise the integrity of a required test or examination. Therefore, the Enforcement Policy was amended to add examples of violations that may be used as guidance in determining the appropriate severity level for violations involving the compromise of applications, tests, and examinations.

F. July 30, 1999: Interim Policy Regarding Enforcement Discretion for Nuclear Power Plants During the Year 2000 Transition

On July 30, 1999, the Commission published a revision to the Enforcement Policy by adding Appendix E. This amendment adds an interim enforcement policy that the NRC will follow to exercise enforcement discretion for noncompliance with license conditions, including technical specifications (TSs), because of year 2000 (Y2K) related situations.

G. August 9, 1999: Interim Enforcement Policy for Use During the NRC Power Reactor Oversight Process Pilot Plant Study

On August 9, 1999, the Commission published a revision to the Enforcement Policy by adding Appendix F. This amendment revises the treatment of violations of 10 CFR Part 50 and associated license conditions during the pilot plant study of the new NRC power reactor oversight process. The Commission is applying this new oversight process to the nine reactor sites that are part of a pilot plant study scheduled to begin in June 1999.

2. Implementation, Staff Guidance, & Initiatives

This section addresses implementation initiatives and changes during fiscal year 1999, including staff guidance and training, upgrade of the Enforcement Action Tracking System, and availability of enforcement information on the Internet.

A. Enforcement Guidance Memoranda (EGMs)

An additional method for the Director, OE, to issue supplemental enforcement guidance is through the issuance of an EGM. EGMs may add guidance for Enforcement Policy application, revise existing guidance on processing enforcement actions, or transmit temporary guidance.

Ten EGMs were issued in fiscal year 1999.

- ◆ EGM 98-009 - Use of Regulatory Significance for Escalated Enforcement Action - Issued November 25, 1998.
- ◆ EGM 99-001 - Guidance for Preparing and Maintaining EA Requests and Enforcement Strategy Forms - Issued January 14, 1999.
- ◆ EGM 99-001A - Guidance for Preparing and Maintaining EA Requests & Enforcement Strategy Forms (Supplement) - Issued February 26, 1999.
- ◆ EGM 99-002(T) - Guidance to Implement Interim Power Reactor NCV Policy - Issued February 26, 1999.

- ◆ EGM 99-003 - Guidance for Distribution of Actions Issued to Individuals - Issued May 7, 1999.
- ◆ EGM 99-004 - Guidance for Enforcement of 10 CFR 34.43, "Training"- Issued June 29, 1999.
- ◆ EGM 98-000, Rev 1 - Guidance for Disposition of Violations of Sections III.G and III.L of Appendix R to 10 CFR Part 50 Involving Circuit Failures - Issued July 21, 1999.
- ◆ EGM 99-005 (T) - Draft Guidance for Interim Enforcement Policy for Generally Licensed Devices - Issued September 8, 1999.
- ◆ EGM 99-006 - Implementation of the Interim Enforcement Policy for Use During the Reactor Oversight Pilot Program - Issued September 20, 1999.
- ◆ EGM 99-007 - Release of Investigative Information from Office of Investigations Reports to Licensees and Subjects of Investigations for Purposes of Predecisional Enforcement Conferences; Preparation of a Written Analysis in Each Discrimination Matter Considered for Enforcement Action - Issued September 20, 1999.

B. Enforcement Training

The Office of Enforcement routinely provides training on the enforcement program through several NRC training courses. During fiscal year 1999, OE provided comprehensive enforcement training in the Fundamentals of Inspection Course (FOIC) in March 1999 and the "NRC: What It Is and What It Does," in September 1999.

The Office of Enforcement also provided extensive training on the revised policy on the treatment of Severity Level IV violations at power reactors (as addressed in EGM 99-002 (T)) by way of video conferencing and regional counterpart meetings.

The regions also provided training on the enforcement program in the regional offices.

C. Enforcement Action Tracking System (EATS) Upgrade

To keep pace with changing technology and to make the system more usable and accessible to NRC personnel, OE upgraded EATS in 1999 from a mainframe environment to a client/server environment. As part of the update (1) EATS was made year-2000 compliant; (2) the system was designed to accommodate new information needs; (3) the system was designed to allow data sharing amongst the agency applications, such as RPS; (4) records created from the old system were moved into the new system; and (5) initial training classes were conducted for OE.

D. Enforcement Information on the Internet

To foster timely and widespread public dissemination of enforcement information, OE continues to electronically publish enforcement information on the Internet. A home page for the enforcement program was established on the World Wide Web in May 1996. In August 1999, OE upgraded its web site to improve staff efficiency and enhance public confidence. The web site includes:

- ▶ a general description of the enforcement program and its mission, including a graphical representation of the graded approach the NRC uses in assessing and dispositioning violations;

- ▶ enforcement contacts;
- ▶ the current Enforcement Policy (NUREG-1600) and individual Policy changes published in the *Federal Register*, since the last NUREG publication in May 1998;
- ▶ copies of significant enforcement actions since March 1996, that the agency has issued arranged by reactor, materials, and individual actions;
- ▶ upcoming predecisional enforcement conferences;
- ▶ the NRC Enforcement Manual (NUREG/BR-0195, Rev. 2) and current EGMs;
- ▶ a discussion on discrimination for raising safety concerns, including the policy statement for "Nuclear Employees Raising Safety Concerns Without Fear of Retaliation," and a link to Department of Labor (DOL) adjudicatory decisions; and
- ▶ OE annual reports for 1997 and 1998.

The Internet address for OE's home page is: www.nrc.gov/OE/.

3. Escalated Enforcement and Administrative Items

During fiscal year 1999, the agency issued 114 individual escalated enforcement items. Escalated enforcement items include individual civil penalties (24), orders (other than orders imposing civil penalties) (17), and Notices of Violation for Severity Level I, II, or III violations (73). Note that an enforcement case or enforcement action issued to a licensee may include more than one individual enforcement item. Table 1 includes a numerical breakdown of escalated enforcement items and Demands for Information issued by each regional office.

Table 2 includes a statistical summary of escalated enforcement items based on the type of licensee, vendor, or individual.

Timeliness of Enforcement Actions

The average time to issue escalated enforcement actions (excluding orders) is a performance measure used by the NRC. For actions that do not involve an investigation, the measurement period begins on the date of the inspection exit meeting. For actions that involve an investigation, but no referral to the Department of Justice (DOJ), the measurement period begins on the date of issuance of the report of investigation. For actions that involve an investigation and referral to DOJ, the measurement period begins on the date DOJ informs the NRC that the NRC may proceed with civil action. For actions that involve discrimination and Department of Labor (DOL) proceedings, the measurement period begins when there is an appropriate decision in the DOL process or sufficient evidence from the NRC's processes to support actions.

On the basis of the defined measurement period, escalated enforcement actions (excluding orders) are to be issued within an average of no more than 90 days. During fiscal year 1999 this standard was met, with enforcement actions issued in an average of 75.2 days. During fiscal year 1998, enforcement actions were issued in an average time of 80.6 days. During fiscal year 1997, enforcement actions were issued in an average time of 88.5 days. During fiscal year 1996, enforcement actions were issued in an average time of 84.5 days.

Civil Penalty Assessment Process: Determining Whether a Civil Penalty Should Be Proposed

If the NRC concludes that a violation should be categorized at Severity Level I, II, or III, the staff then considers whether (for a licensed facility), a civil penalty should be proposed for the violation. For the

majority of cases, in accordance with Section VI.B.2 of the Enforcement Policy, the civil penalty assessment process considers:

- ▶ whether the licensee has had any previous escalated enforcement action (regardless of the activity area) during the past 2 years or past 2 inspections, whichever is longer;
- ▶ whether the licensee should be given credit for actions related to identification;
- ▶ whether the licensee’s corrective actions are prompt and comprehensive; and
- ▶ whether, in view of all the circumstances, the matter in question requires the exercise of discretion.

Depending on the outcome of the civil penalty process, the staff will conclude whether an escalated Notice of Violation should be issued with or without a civil penalty. Figure 1 of this report includes a graphic representation of the civil penalty process and includes a statistical breakdown of the individual enforcement issues or enforcement items assessed under the process. It should be noted that an enforcement case or enforcement action issued to a licensee may include more than one individual enforcement item. It should also be noted that this number does not directly correlate to the 97 escalated Notices of Violation (NOV) issued with and without civil penalties in Table 1 (73 NOVs and 24 civil penalties) because the civil penalty assessment process only applies to licensees and because not all cases were assessed under the civil penalty assessment process.

Total Escalated NOVs w/o penalty and civil penalties		NOVs Issued to Individuals		NOV Issued to a Vendor		Beyond Statute of Limitations		Enforcement Discretion		
97	-	19	-	1	-	1	-	9	=	67

Specifically, 19 Notices of Violation were issued to individuals, 1 Notice of Violation was issued to a vendor, 1 case beyond the 5-year Statute of Limitations for issuing a civil penalty, and 9 enforcement issues were based solely on an exercise of discretion in accordance with Section VII.A of the Enforcement Policy (Escalation of Enforcement Sanctions) or Section VII.B.2 (Violations Identified During Extended Shutdowns) or Section VII.B.6 (Violations Involving Special Circumstances). Figure 2 of this report includes a graphic representation of the civil penalty process and includes a statistical breakdown of the 26 individual reactor enforcement issues or enforcement items assessed under the process. Figure 3 includes the statistical breakdown of the 41 individual materials enforcement items. Figures 4 through 15 include the statistical breakdown of enforcement issues based on the 12 possible paths of the civil penalty assessment process flowchart.

A. Escalated Notices of Violation (Without Civil Penalties)

During fiscal year 1999, the agency issued 73 escalated Notices of Violation (without civil penalties). (This number reflects the number of individual enforcement issues versus the number of enforcement cases issued during the year.) Twenty of these items were issued to individuals and other non-licensed persons. See Section 5 for more information on enforcement items issued to individuals and other non-licensed persons. Appendix A includes a short summary description of each of the enforcement issues as well as a summary of the civil penalty assessment process, i.e., why a civil penalty was not proposed.

B. Civil Penalty Actions

During fiscal year 1999, the agency issued 24 individual civil penalty issues. Appendix B includes a short summary description of each of these items, as well as a summary of the civil penalty assessment process, i.e., why a civil penalty was proposed. Table 3 includes statistical information on civil penalties and Table 4 includes a statistical analysis of the range of civil penalties for both reactor and materials licensees. As stated before, an enforcement action may include more than one individual civil penalty issue.

During fiscal year 1999, one enforcement action included a civil penalty in excess of \$300,000. On October 13, 1998, the NRC issued a civil penalty in the amount of \$500,000 to Indiana Michigan Power Company for a Severity Level II problem at the D.C. Cook facility (EA 98-150).

C. Orders

During fiscal year 1999, the agency issued 17 orders. Two of these orders were issued to licensees while two were issued to vendors and 13 of the orders were issued to individuals. (See Section 5 for more information on enforcement actions issued to individuals and other non-licensed persons.) Appendix C includes a short summary description of the two orders issued to licensees. In addition, five civil penalty imposition orders were issued.

D. Demands for Information

During fiscal year 1999, the agency issued two formal Demands for Information (DFI). One DFI was issued to a licensee and one DFI was issued to an individual. Appendix D includes a short summary description of the DFI to the licensee and Appendix G includes a short description of the DFI to the individual. (See Section 5 for more information on actions issued to individuals.)

E. Summary of Significant Actions

The NRC considers violations categorized at Severity Level I and II to be very significant. The agency also considers enforcement actions consisting of multiple Severity Level III violations to be very significant. During fiscal year 1999, the agency did not issue any enforcement cases including Severity Level I issues. The agency issued 10 enforcement cases including 14 individual Severity Level II issues. The agency issued four multi-action enforcement cases including 10 individual Severity Level III issues. These significant cases are listed below. Case summaries are included in the referenced appendix.

SEVERITY LEVEL I CASES

None.

SEVERITY LEVEL II CASES

***Anvil Corporation, Bellingham, WA
Supplements IV & VI***

(EA 99-083)

A Notice of Violation and Proposed Imposition of Civil Penalty in the amount of \$8,800 was issued on June 28, 1999. This action was based on a Severity Level II problem that involved multiple failures to maintain occupational radiation doses, supervise radiographic operations, perform surveys, and wear an operating alarm ratemeter. (Appendix B).

***DAS Consult, Inc., Dublin, OH
Supplement VI***

(EA 98-492)

A Notice of Violation was issued on March 31, 1999. The action was based on a Severity Level II violation involving the deliberate unauthorized transfer of byproduct material. (Appendix A).

***FirstEnergy Nuclear Operating Company, Perry Nuclear Power Plant
Supplement VII***

(EA 99-012)

A Notice of Violation and Proposed Imposition of Civil Penalty in the amount of \$110,000 was issued on May 20, 1999. This action was based on a Severity Level II violation involving discrimination against an employee for raising safety concerns. (Appendix B).

***Indiana Michigan Power Company, Donald C. Cook
Supplement I***

(EA 98-150)

A Notice of Violation and Proposed Imposition of Civil Penalties in the amount of \$500,000 was issued on October 13, 1998, for a Severity Level II problem consisting of 37 violations. The violations stemmed from the breakdown in the control of activities that led to the material degradation of multiple systems, including the ice condensers, at the Donald C. Cook units. (Appendix B).

***International Radiography & Inspection
Supplements IV & VI***

(EA 98-565 & EA 99-090)

A Notice of Violation and Proposed Imposition of Civil Penalties in the amount of \$17,600 was issued on May 4, 1999, for two Severity Level II problems. The action was based on multiple willful violations including, failing to limit an occupational exposure to NRC limits, failing to have a radiation survey instrument and to conduct radiation surveys at a job site where radiography was being conducted, failing to utilize personnel radiation monitoring equipment, failing to stop radiography and contact the radiation safety officer when the incident occurred, and failing to complete and maintain required records. (Appendix B).

***Maine Yankee Atomic Power Company, Maine Yankee Atomic Power Station
Supplement I***

***(EAs 96-299;
96-320;96-397;97-034; 97-147; 97-375; 97-559)***

A Notice of Violation for a Severity Level II problem was issued on October 8, 1998. The Severity Level II violation was based on the licensee operating the facility without having demonstrated that its ECCS systems were capable of mitigating the most severe postulated loss-of-coolant accident. Four Severity Level III problems were also issued with the action (see discussion below). (Appendix A).

**Marshall Miller & Associates
Supplement VI****(EA 97-444 & EA 98-313)**

A Notice of Violation and Proposed Imposition of Civil Penalties in the amount of \$8,800 was issued on January 29, 1998, for two Severity Level II problems. The action was based on multiple failures to adhere to safety and regulatory barriers involving a 125-millicurie cesium 137 well logging source, and failure to provide NRC with complete and accurate information involving training records and radiation survey and utilization records. (Appendix B).

**Northeast Nuclear Energy Company (NNECo), Millstone
Supplement I,****(EA 97-461)**

A Notice of Violation and Proposed Imposition of Civil Penalty in the amount of \$88,000 was issued on March 9, 1999. This action was based a Severity Level II violation involving the termination of two contractor employees involved in the Motor Operated Valve (MOV) department as retaliation for engaging in protected activities. (Appendix B).

**Northeast Nuclear Energy Company (NNECo), Millstone
Supplement VI****(EA 98-325)**

A Notice of Violation was issued on April 6, 1999. This action was based on three Severity Level II violations related to discrimination of plant employees. (Appendix A).

**XRI Testing, Troy, MI
Supplement VI****(EA 98-507)**

A Notice of Violation was issued on February 25, 1999. This action was based a Severity Level II problem involving: (1) failure of a radiographer to wear an alarming ratemeter, (2) failure to have two qualified individuals present during radiographic operations, (3) failure to maintain continuous direct visual surveillance of radiographic operations, and (4) failure to conduct a survey of the device or the guide tube prior to manipulating the collimator, which resulted in a significant radiation exposure to the radiographer's hand. (Appendix A).

MULTIPLE SEVERITY LEVEL III CASES**Baxter Healthcare Corporation, Albonito, PR
Supplement VI****(EA 97-518)**

A Notice of Violation and Proposed Imposition of Civil Penalties in the amount of \$10,500 was issued on October 9, 1998, for two Severity Level III violations. The first violation was based on willful, unauthorized bypassing of a safety system interlock on an irradiator. The second violation was based on three additional examples where the licensee conducted subsequent, unauthorized repairs to equipment affecting the irradiator control console's "on-off" mechanism. (Appendix B).

***Entergy Operations, Inc., River Bend Station
Supplement I,***

(EA 98-478)

A Notice of Violation and Proposed Imposition of Civil Penalty in the amount of \$55,000 was issued on February 1, 1999. This action was based on two Severity Level III violations. The first violation involved a design deficiency that caused uncertainty as to the ability of the Division I and II Emergency Diesel Generators (EDGs) to perform their intended safety function under design basis accident conditions and rendered the EDGs incapable of complying with the technical specification definition of operability since original installation. The second Severity Level III violation involved the licensee's failure to ensure design control measures adequately verified that the EDGs would have remained operable during certain periods of operations. (Appendix B).

***Maine Yankee Atomic Power Company, Maine Yankee Atomic Power Station
Supplement I***

***(EAs 96-299;
96-320; 96-397; 97-034; 97-147; 97-375; 97-559)***

A Notice of Violation for four Severity Level III problems was issued on October 8, 1998. The Severity Level III problems were related to four broad categories, namely, the failure to: (1) adequately test equipment; (2) environmentally qualify equipment; (3) perform adequate safety reviews; and (4) either identify deficiencies, or take appropriate corrective actions in a timely manner to address known deficiencies, including design related issues. Some of the violations led to safety equipment being inoperable or degraded for extended periods contrary to technical specifications. A Severity Level II violation was also issued with the action (see the discussion above). (Appendix A).

***Testing Engineers & Consultants, Troy, MI
Supplement IV***

(EA 99-097 & EA 99-169)

A Notice of Violation and Proposed Imposition of Civil Penalties in the amount of \$5,500 was issued on July 8, 1999. This action was based on two willful Severity Level III violations involving the failure to secure and control licensed material and the failure to provide the NRC with complete and accurate information regarding the licensed material (moisture density gauge). (Appendix B).

F. Escalated Enforcement Trends

During fiscal year 1999, the agency issued 119 individual escalated issues (73 escalated NOVs, 24 civil penalties, 17 orders, and 5 impositions) to reactor and materials licensees and individuals and vendors. This represents the smallest number of escalated actions issued within a five-year period.

Escalated Enforcement Trends

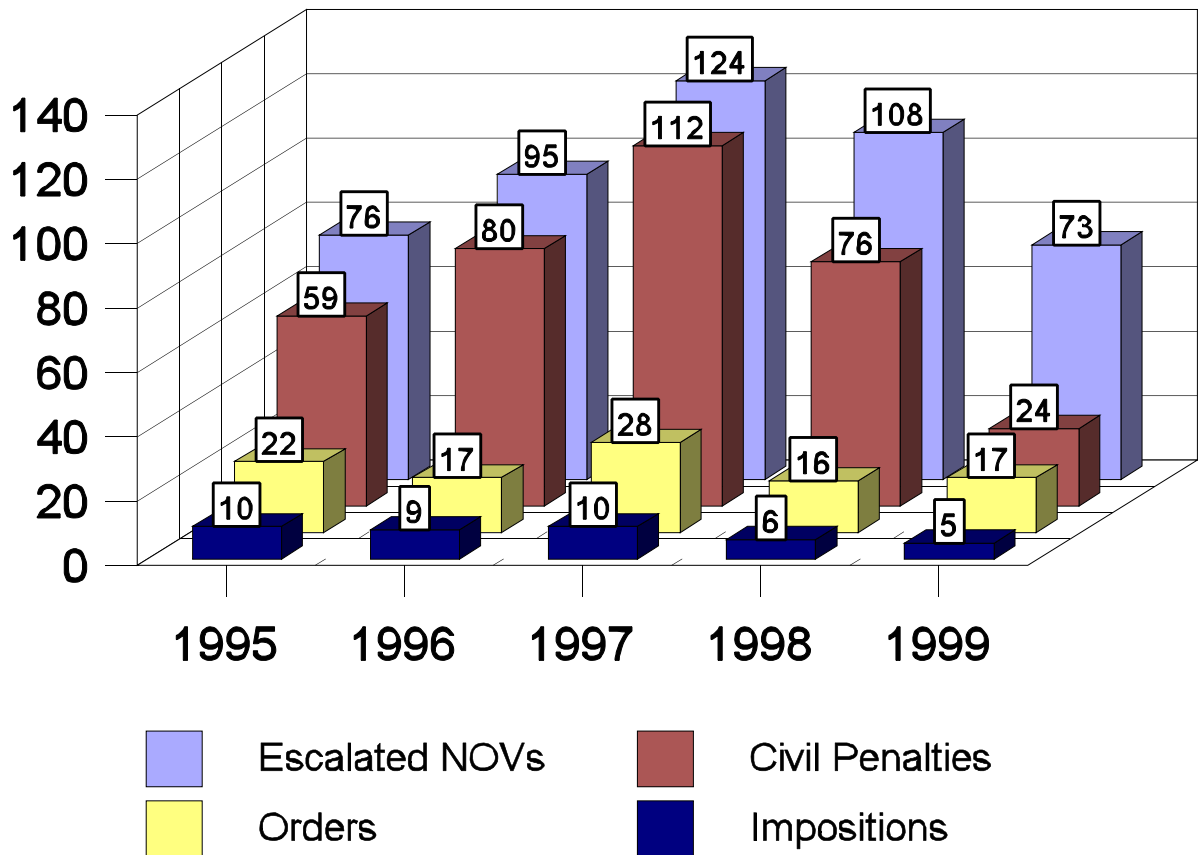

Figure 1

Statistical comparisons between fiscal years 1999, 1998, 1997, 1996, and 1995 are included in each of the tables of this report. However, it should be noted that direct correlations between the fiscal years is difficult because of the major policy change that occurred in June of 1995 and the change in enforcement guidance and focus in November 1998 (EGM 98-009, “Use of Regulatory Significance in Escalated Enforcement Action”). The reduction in the number of escalated enforcement actions is the result of the agency’s efforts in establishing an Enforcement Policy that strives to be more risk-informed and performance-based.

The next page includes a breakdown of escalated enforcement trends by operating reactors, material licensees, and individuals (including vendors).

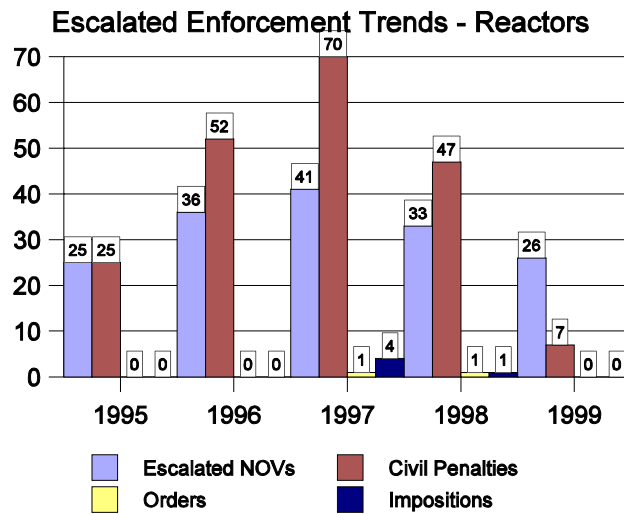

Figure 2

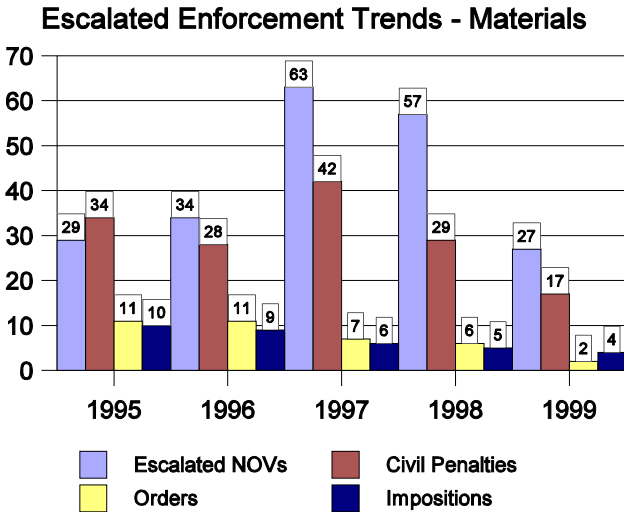

Figure 3

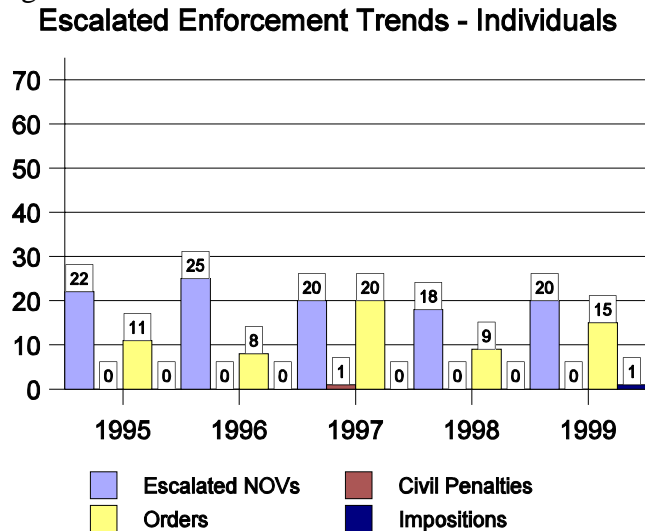

Figure 4

Operating Reactor Escalated Enforcement Trends

Table 5 of this report includes a 2-year history of individual escalated enforcement items by specific reactor sites. Based on a 2-year period, reactor sites are ranked in order of the largest civil penalty amounts assessed and the largest total number of combined civil penalty items and escalated Notices of Violations without civil penalties issued. A 2-year period is used for this ranking because it represents a sufficient time-frame to provide perspectives on performance and enforcement activity. Two years is also the time period used in the Enforcement Policy for reviewing past performance. This table also provides enforcement data for the last 12 months at each of the sites listed. Unlike other tables that include data based on *proposed* actions, the data in this table accounts for any withdrawals or modifications from the original proposed action.

2-Year Escalated Enforcement Review

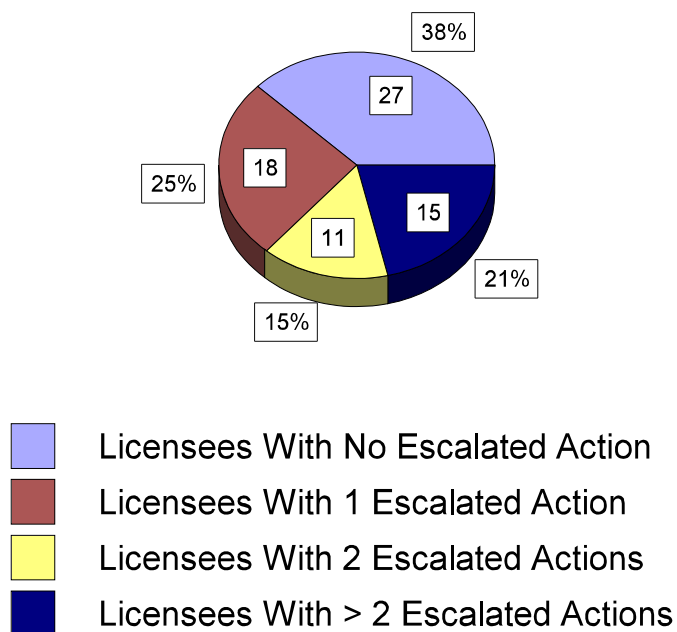

Figure 5

During the 2-year period between fiscal years 1998 and 1999, the agency issued a total of 113 individual civil penalties and individual Severity I, II, and III Notices of Violation without civil penalties to 44 (or 62%) of the reactor sites. Twenty-seven sites did not receive any escalated enforcement action during this period. Of the 44 sites, 18 sites received 1 escalated enforcement item (18 issues), 11 sites received 2 individual escalated enforcement items (22 issues), and 15 sites received more than 2 individual escalated enforcement items (73 issues). Thus, 15 sites (or 21%) accounted for 73 (or 65%) of the escalated actions issued.

Of the 113 individual escalated items, 54 were civil penalties issued to 31 (or 44%) of the 71 reactor sites. Forty (or 56%) of the sites did not receive a civil penalty. Of the 31 sites that did receive a penalty, 22 sites had 1 civil penalty item (22 civil penalties) 2 sites had 2 individual civil penalty items each (4 civil penalties), and 7 sites had more than 2 individual civil penalty items (28 civil penalties) for

a total of 54 individual civil penalties. Thus, 7 sites (or 10%) accounted for 28 (or 52%) of the civil penalties issued.



Figure 6

This graph shows the dramatic decline in the number of operating reactor licenses that received a civil penalty in the fiscal year. A detailed breakdown of civil penalty information is included below.

Fiscal Year 1999

- ▶ 65 licensees did not receive a civil penalty (CP)
- ▶ 6 licensees received civil penalties (7 individual CPs)
- ▶ 0 licensees had more than 2 civil penalties
- ▶ 1 licensee had 2 CPs ☞ 29% of CPs
- ▶ 5 licensees had 1 CP ☞ 71% of CPs

Fiscal Year 1998

- ▶ 42 licensees did not receive a civil penalty (CP)
- ▶ 29 licensees received civil penalties (46 individual CPs)
- ▶ 5 licensees had more than 2 civil penalties (20 individual CPs) ☞ 43% of CPs
- ▶ 2 licensees had 2 CPs (4 individual CPs) ☞ 9% of CPs
- ▶ 22 licensees had 1 CP (22 individual CPs) ☞ 48% of CPs

Fiscal Year 1997

- ▶ 36 licensees did not receive a civil penalty (CP)
- ▶ 35 licensees received civil penalties (70 individual CPs)
- ▶ 9 licensees had more than 2 civil penalties (35 individual CPs) ≈ 50% of CPs
- ▶ 9 licensees had 2 CPs (18 individual CPs) ≈ 26% of CPs
- ▶ 17 licensees had 1 CP (17 individual CPs) ≈ 24% of CPs

Fiscal Year 1996

- ▶ 42 licensees did not receive a civil penalty (CP)
- ▶ 29 licensees received civil penalties (50 individual CPs)
- ▶ 5 licensees had more than 2 civil penalties (21 individual CPs) ≈ 42% of CPs
- ▶ 5 licensees had 2 CPs (10 individual CPs) ≈ 20% of CPs
- ▶ 19 licensees had 1 CP (19 individual CPs) ≈ 38% of CPs

Fiscal Year 1995

- ▶ 56 licensees did not receive a civil penalty (CP)
- ▶ 15 licensees received civil penalties (25 individual CPs)
- ▶ 4 licensees had more than 2 civil penalties (14 individual CPs) ≈ 56% of CPs
- ▶ 0 licensees had 2 CPs
- ▶ 11 licensees had 1 CP (11 individual CPs) ≈ 44% of CPs

4. Cases Involving Exercise of Discretion

Section VII of the Enforcement Policy addresses those cases where, notwithstanding the normal guidance contained in the Policy, the NRC may choose to exercise discretion and either escalate or mitigate enforcement sanctions within the Commission's statutory authority to ensure that the resulting enforcement action appropriately reflects the level of NRC concern regarding the violation at issue and conveys the appropriate message to the licensee. During fiscal year 1999, 32 escalated cases (including 39 individual issues) involved an exercise of discretion. 21 of the cases (including 27 issues) were for reactor licensees and 11 cases (including 12 issues) were for materials licensees.

Section VII.A of the Enforcement Policy provides that the NRC may increase a sanction up to its full enforcement authority where the action is warranted without applying the normal civil penalty assessment process (Section VI.B.2). It also provides for either increasing the amounts of civil penalties or proposing civil penalties where the normal process would result in no civil penalty. During fiscal year 1999, seven cases (including eight issues) involved this exercise of discretion. Two cases were for reactor licensees and five cases (six issues) were for materials licensees.

Section VII.B.1 provides that NOV's need not be issued for Severity Level IV violations that meet specific criteria. Cases that are subject to this enforcement discretion are not described in this report.

Section VII.B.2 provides that civil penalties or NOV's need not be issued for violations identified during extended shutdowns or work stoppages if they are licensee-identified, based upon activities prior to the events leading to the shutdown, non-willful, and not categorized at Severity Level I. This exercise of discretion provides that the licensee's decision to restart the plant requires NRC concurrence. During fiscal year 1999, two cases involved this exercise of discretion. These cases were for reactor licensees.

Section VII.B.3 provides that civil penalties or NOV's need not be issued for old design issues that are licensee-identified and corrected and were not likely to have been identified earlier through routine surveillance. During fiscal year 1999, seven cases involved this exercise of discretion. These cases were for reactor licensees.

Section VII.B.4 provides that civil penalties or NOV's need not be issued for violations identified due to previous escalated enforcement action if the violation was licensee-identified, it has a similar root cause as a previous escalated action, it does not substantially change the regulatory concern out of the initial action, and it was corrected. During fiscal year 1999, one case (including several violations) involved this exercise of discretion. This case was for a reactor licensee.

Section VII.B.5 provides that civil penalties or NOV's need not be issued for violations involving discrimination issues if they are licensee-identified and corrected. During fiscal year 1999, no cases involved this exercise of discretion.

Section VII.B.6 provides that civil penalties or NOV's need not be issued for violations involving special circumstances. During fiscal year 1999, 15 cases involved this exercise of discretion. Nine cases (including 15 issues) were for reactor licensees and six cases were for materials licensees.

Appendix E includes a summary of the escalated cases issued during fiscal year 1999 that involved an exercise of discretion.

5. Actions Against Individuals & Other Non-Licensed Persons

During fiscal year 1999, the agency issued 36 actions against individuals and other non-licensed persons. The following sections provide a breakdown of the actions based on whether the actions were issued to licensed or non-licensed individuals, as well as other non-licensed persons (e.g., vendors). The section on orders includes orders that were issued to individuals that prohibited or limited their activities in NRC-licensed activities during the fiscal year.

A. Actions Against Licensed Individuals

During fiscal year 1999, the agency issued 4 NOV's to licensed individuals. Appendix F includes a short summary description of these actions.

B. Actions Against Non-Licensed Individuals

During fiscal year 1999, the agency issued 13 orders, 15 NOV's, and 1 DFI, to non-licensed individuals. Appendix G includes a short summary description of each of these actions.

C. Actions Against Non-Licensed Persons Other Than Individuals

During fiscal year 1999, the agency issued 1 imposition, 2 orders, and 1 NOV to non-licensed persons (vendors) other than an individual. Appendix H includes a short summary description of these actions.

6. Cases Involving Discrimination

During fiscal year 1999, the agency issued 12 enforcement actions for violations involving discrimination. Six actions were issued to licensees, two were issued to vendors, and four were issued to individuals. Appendix I includes a short description of each of the actions involving discrimination that were issued during the fiscal year.

7. Hearing Activities

During fiscal year 1999, four cases had some type of hearing activity, i.e., hearing request, settlement, dismissal, discovery, hearing proceeding, appeal, etc. Appendix J includes a short summary of each of these cases.

8. 10 CFR 2.206 Petitions

During fiscal year 1999, there was one case that had some type of petition activity pending before the Office of Enforcement during the fiscal year, i.e., petition request, NRC staff review, Director's Decision, etc.

9. Withdrawn and Modified Enforcement Actions

During fiscal year 1999, there was one enforcement action that was completely withdrawn. This case, which involved an Order prohibiting involvement in NRC-licensed activities, is described in Appendix L.

TABLE 1: ESCALATED ENFORCEMENT ITEMS & DEMANDS FOR INFORMATION

	Region I	Region II	Region III	Region IV	Other ¹	Total FY 99	Total FY 98	Total FY97	Total FY 96	Total FY 95
Conferences	22	8	13	9	0	52	122	181	143	117
Escalated NOVs w/o Civil Penalties	31	7	18	16	1	73	108	124	96	76
Proposed Civil Penalties	8	4	6	6	0	24	76	112	78	56
Imposed Civil Penalties	1	0	2	1	1	5	6	10	9	10
Civil Penalties Paid	7	4	5	6	0	22	68	108	56	47
Orders	5	2	5	2	3	17	16	28	17	22
Demands for Information	0	0	1	0	1	2	6	35	7	8
Total	74	25	50	40	6	195	402	597	405	339

¹ This category includes actions initiated by the Office of Enforcement (OE), the Office of Nuclear Reactor Regulation (NRR), and the Office of Nuclear Material Safety and Safeguards (NMSS). During this fiscal year:

- ◆ OE issued 1 escalated NOV without a civil penalty and imposed 1 civil penalty.
- ◆ NMSS issued 3 orders and 1 Demand for Information.

PAGE INTENTIONALLY LEFT BLANK

**TABLE 2: ESCALATED ENFORCEMENT ITEMS
BY TYPE OF LICENSEE, VENDOR, OR INDIVIDUAL**

Type of Licensee	Escalated NOVs (w/o penalty)	Civil Penalties	Orders	Total FY99	Total FY98	Total FY97	Total FY 96	Total FY 95
Academic	2	0	0	2	4	3	5	3
Physician	0	0	0	0	7	9	3	2
Fuel Facility	1	1	0	2	6	5	3	1
Gauge User	5	6	1	12	26	31	23	29
Hospital	6	2	0	8	13	33	13	12
Irradiator	0	2	0	2	0	1	0	0
Radiographer	3	2	1	6	8	9	12	11
Pharmacy	1	0	0	1	1	0	1	3
Operating Reactor	26	7	0	33	81	112	87	50
Research Reactor	0	0	0	0	2	0	0	0
Materials Distributer	6	1	0	7	2	1	2	0
Mill	0	0	0	0	0	1	1	0
Other	2	1	0	3	19	17	10	11
Waste Disposal	1	0	0	1	0	0	0	0
Well Logger	0	2	0	2	4	1	0	0
Vendor	1	0	2	3	1	1	8	5
Licensed Individual	4	0	0	4	7	2	6	7
Non-Licensed Individual	15	0	13	28	19	38	19	23
Total	73	24	17	114	200	264	191	159

PAGE INTENTIONALLY LEFT BLANK

TABLE 3: CIVIL PENALTY INFORMATION

	FY99	FY98	FY97	FY 96	FY 95
Number of Proposed Civil Penalties	24	76	112	78	59
Number of Imposed Civil Penalties	5	6	10	9	10
Number of Civil Penalties Paid	21	68	108	56	47
Amount of Proposed Civil Penalties	\$1,062,600	\$5,206,600	\$7,422,300	\$3,832,500	\$2,263,950
Amount of Imposed Civil Penalties	\$913,750	\$115,650	\$285,250	\$44,500	\$615,250
Amount of Civil Penalties Paid	\$,1070,850	\$6,493,573	\$6,657,300	\$3,014,000	\$2,265,949

NOTE: This table includes information based on individual civil penalty assessments. An enforcement action may include more than one individual civil penalty. In addition, a civil penalty may be proposed in one fiscal year and paid or imposed in another fiscal year.

PAGE INTENTIONALLY LEFT BLANK

TABLE 4: CIVIL PENALTY RANGES

Reactor Licensees

Civil Penalty Amounts	Number of Penalties FY99	Number of Penalties FY 98	Number of Penalties FY 97	Number of Penalties FY 96	Number of Penalties FY 95
< \$50,000	0	0	1	0	3
\$50,000 - 55,000	4	35	41	24	7
\$55,001 - \$99,999	1	2	2	5	3
\$100,000 - 110,000	1	6	17	21	9
\$110,001 - \$200,000	0	0	6	0	3
\$200,001 - \$300,000	0	1	2	0	0
> \$300,001	1	3	1	0	0
Total	7	47	70	50	25

Material Licensees

Civil Penalty Amounts	Number of Penalties FY99	Number of Penalties FY 98	Number of Penalties FY 97	Number of Penalties FY 96	Number of Penalties FY 95
0 - \$2,500	1	3	12	18	9
\$2,501 - \$5,000	8	10	17	2	12
\$5,001 - \$7,500	3	4	2	1	3
\$7,501 - \$10,000	3	4	5	4	3
\$10,001 - \$25,000	1	3	4	3	6
\$27,500	0	2	0	0	1
\$55,000	1	3	0	0	0
\$100,000	0	0	1	0	0
\$200,000	0	0	0	0	0
Total	17	29	41	28	34

NOTE: This table includes information based on individual proposed civil penalty assessments. An enforcement action may include more than one individual civil penalty. In addition, this table does not include the \$900,000 penalty issued to a vendor in fiscal year 1997.

PAGE INTENTIONALLY LEFT BLANK

**TABLE 5: 2-YEAR ESCALATED ITEM HISTORY
FOR REACTOR SITES**

Facility	FY 1998 - FY 1999			FY 1999		
	Civil Penalty Amount	Civil Penalties	Escalated NOVs (w/o penalty)	Civil Penalty Amount	Civil Penalties	Escalated NOVs (w/o penalty)
Millstone	\$2,243,000	6	6	\$88,000	1	5
Cook	\$500,000	1	1	\$500,000	1	0
Quad Cities	\$473,000	4	1	0	0	1
Pilgrim	\$220,000	4	0	0	0	0
Indian Point 2	\$220,000	4	1	0	0	0
Three Mile Island	\$210,000	4	2	0	0	0
Perry	\$210,000	3	1	\$110,000	1	0
River Bend Station	\$165,000	3	2	\$110,000	2	1
Waterford	\$110,000	1	3	0	0	2
Cooper	\$110,000	1	0	0	0	0
Fort Calhoun	\$110,000	1	0	0	0	0
Zion	\$110,000	1	2	0	0	2
Nine Mile Point	\$105,000	2	1	0	0	1
Palo Verde	\$105,000	2	0	\$55,000	1	0
St. Lucie	\$88,000	1	2	0	0	0
Oyster Creek	\$55,000	1	4	0	0	0
Hope Creek	\$55,000	1	2	0	0	0
Braidwood	\$55,000	1	1	0	0	0
Byron	\$55,000	1	1	0	0	0
Calvert Cliffs	\$55,000	1	1	0	0	0
Robinson	\$55,000	1	1	0	0	0
Seabrook	\$55,000	1	1	\$55,000	1	0
Beaver Valley	\$55,000	1	0	0	0	0
Indian Point 3	\$55,000	1	0	0	0	0
Limerick	\$55,000	1	0	0	0	0
Palisades	\$55,000	1	0	0	0	0
Peach Bottom	\$55,000	1	0	0	0	0

**TABLE 5: 2-YEAR ESCALATED ITEM HISTORY
FOR REACTOR SITES - CONT.**

Facility	FY 1997 - FY 1998			FY 1998		
	Civil Penalty Amount	Civil Penalties	Escalated NOVs (w/o penalty)	Civil Penalty Amount	Civil Penalties	Escalated NOVs (w/o penalty)
Shearon Harris	\$55,000	1	0	0	0	0
Susquehanna	\$55,000	1	0	0	0	0
Vermont Yankee	\$55,000	1	0	0	0	0
Prairie Island	\$50,000	1	0	0	0	0
Maine Yankee	0	0	5	0	0	5
WNP-2	0	0	3	0	0	1
Catawba	0	0	2	0	0	1
Haddam Neck	0	0	2	0	0	1
Salem	0	0	2	0	0	0
San Onofre	0	0	2	0	0	1
ANO	0	0	1	0	0	0
Clinton	0	0	1	0	0	1
Dresden	0	0	1	0	0	0
LaSalle	0	0	1	0	0	1
Oconee	0	0	1	0	0	0
Point Beach	0	0	1	0	0	1
Watts Bar	0	0	1	0	0	0

FIGURE 7: ANALYSIS OF ESCALATED ITEMS PROCESSED UNDER CIVIL PENALTY PROCESS

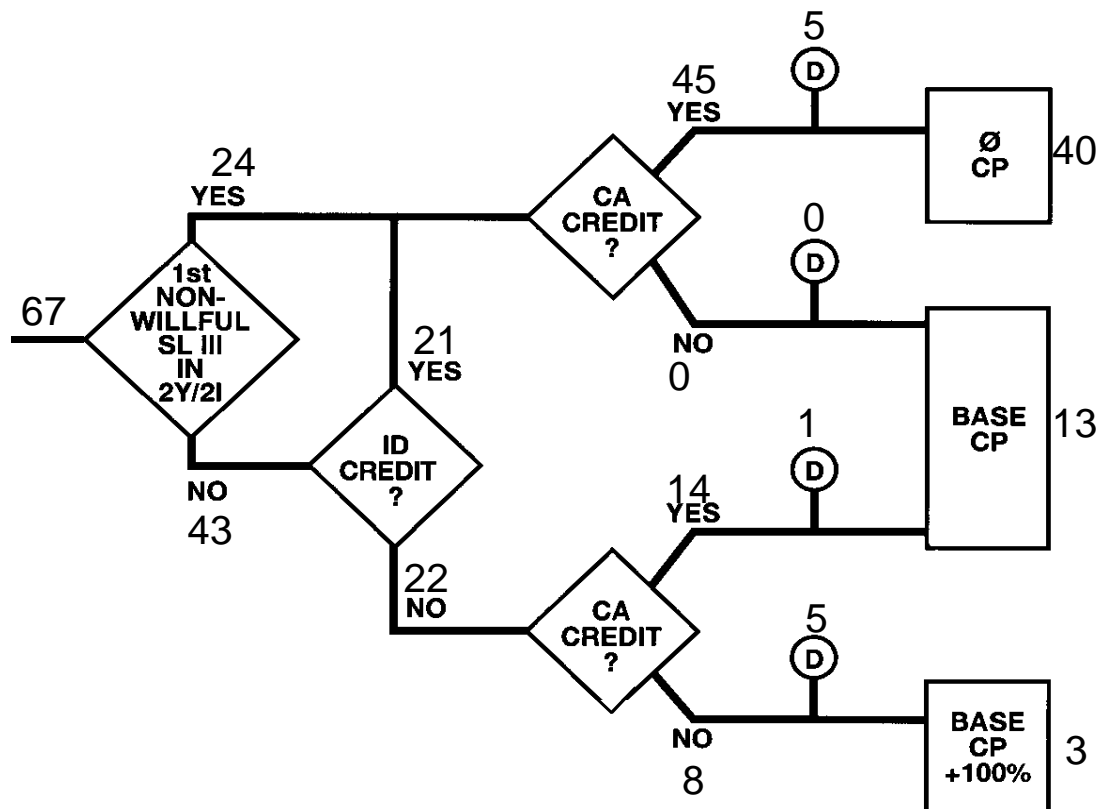

67 individual enforcement items were evaluated in accordance with the civil penalty assessment process.

In 24 instances, the item was the first non-willful Severity Level III enforcement issue that the licensee had during the past 2 years or past 2 inspections.

In 43 instances, the item was NOT the first non-willful Severity Level III enforcement issue that the licensee had during the past 2 years or past 2 inspections.

Of the 43 applicable items, the licensee was given credit for actions related to identification in 21 instances and NOT given credit in 22 instances.

Of the total 67 items, the licensee was given credit for corrective actions in 59 instances (88% of the items) and NOT given credit in 8 instances.

Discretion was exercised in 11 instances (6 times under Section VII.A.1 and 5 times under VII.B.6). This represents approximately 16% of the individual enforcement issues.

PAGE INTENTIONALLY LEFT BLANK

FIGURE 8: ANALYSIS OF REACTOR ITEMS PROCESSED UNDER CIVIL PENALTY PROCESS

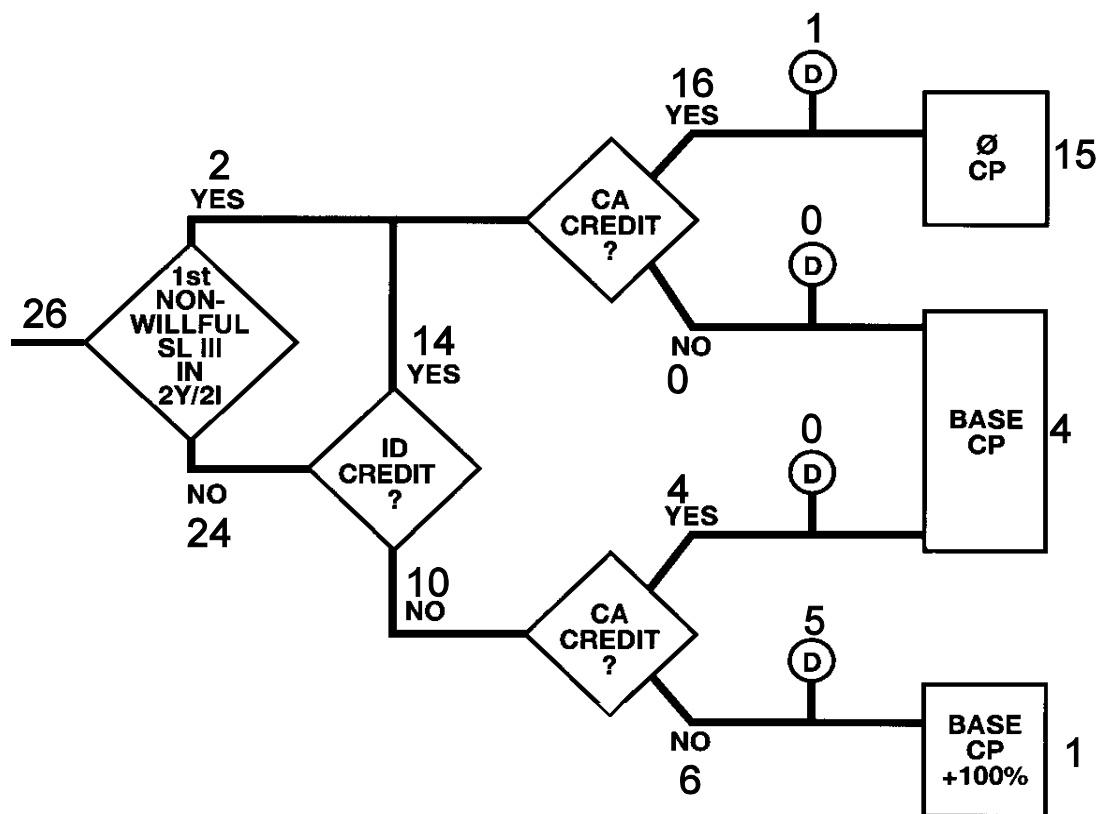

26 individual reactor enforcement items were evaluated in accordance with the civil penalty assessment process.

In 2 instances, the item was the first non-willful Severity Level III enforcement issue that the licensee had during the past 2 years or past 2 inspections.

In 24 instances, the item was NOT the first non-willful Severity Level III enforcement action that the licensee had during the past 2 years or past 2 inspections.

Of the 24 applicable items, the licensee was given credit for actions related to identification in 14 instances and NOT given credit in 10 instances.

Of the total 26 items, the licensee was given credit for corrective actions in 20 cases (approximately 77% of the items) and NOT given credit in 6 instances.

Discretion was exercised in 6 instances (1 time under Section VII.A.1 and 5 times under Section VII.B.6). This represents approximately 23% of the individual reactor enforcement issues.

PAGE INTENTIONALLY LEFT BLANK

FIGURE 9: ANALYSIS OF MATERIALS ITEMS PROCESSED UNDER CIVIL PENALTY PROCESS

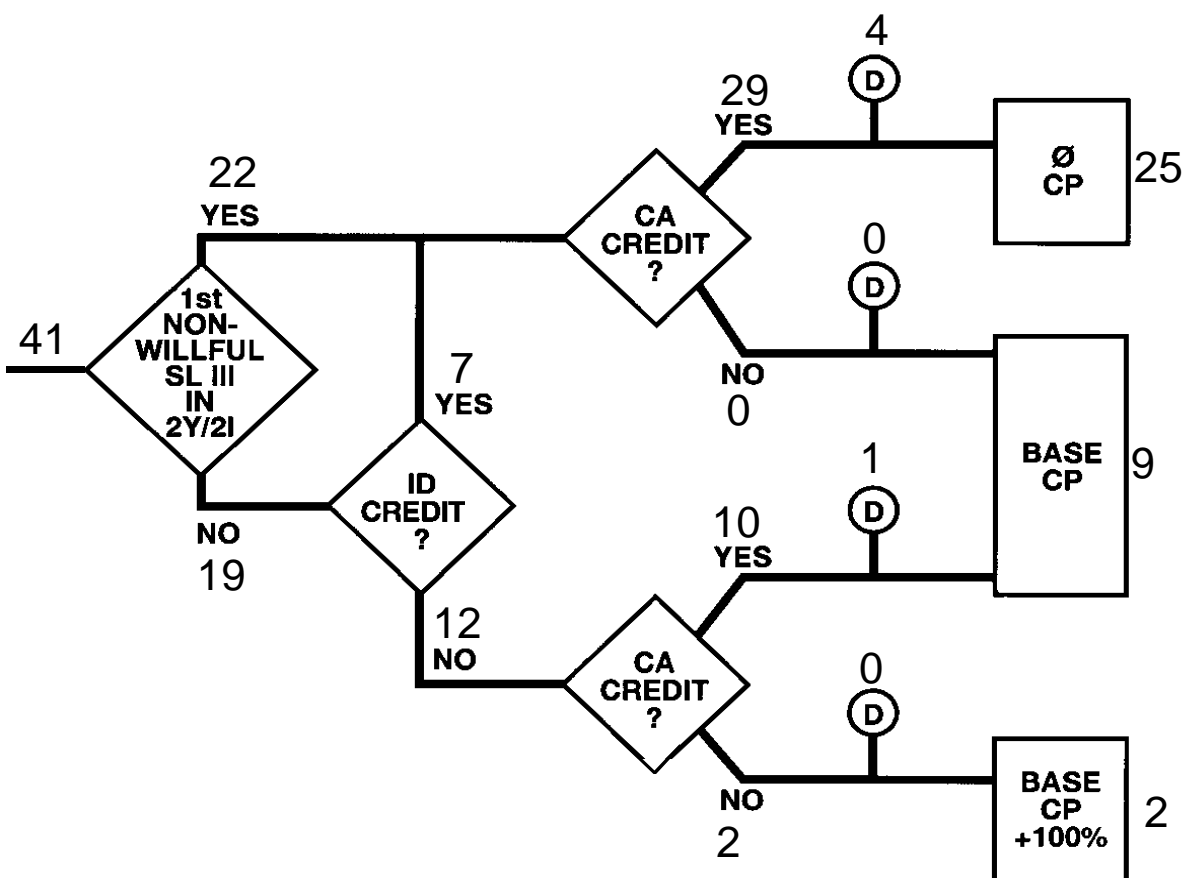

41 individual reactor enforcement items were evaluated in accordance with the civil penalty assessment process.

In 22 instances, the item was the first non-willful Severity Level III enforcement issue that the licensee had during the past 2 years or past 2 inspections.

In 19 instances, the item was NOT the first non-willful Severity Level III enforcement action that the licensee had during the past 2 years or past 2 inspections.

Of the 19 applicable items, the licensee was given credit for actions related to identification in 7 instances and NOT given credit in 12 instances.

Of the total 41 items, the licensee was given credit for corrective actions in 39 cases (approximately 95% of the items) and NOT given credit in 2 instances.

Discretion was exercised in 5 instances (5 times under Section VII.A.1). This represents approximately 12% of the individual materials enforcement issues.

PAGE INTENTIONALLY LEFT BLANK

**FIGURE 10: CIVIL PENALTY PROCESS
PATH A**

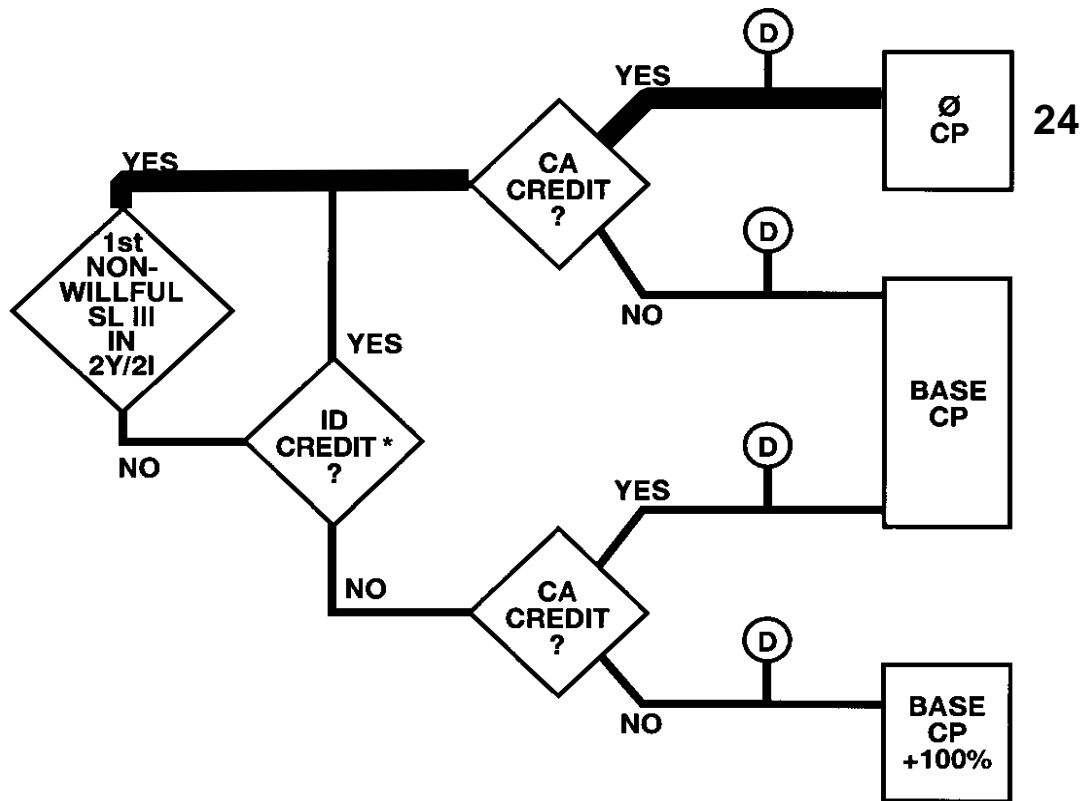

In 24 instances, the item was the first non-willful Severity Level III enforcement issue that the licensee had during the past 2 years or past 2 inspections and the licensee received credit for corrective actions.

2 of the items were for reactor licensees.

22 of the items were for materials licensees.

PAGE INTENTIONALLY LEFT BLANK

**FIGURE 11: CIVIL PENALTY PROCESS
PATH B**

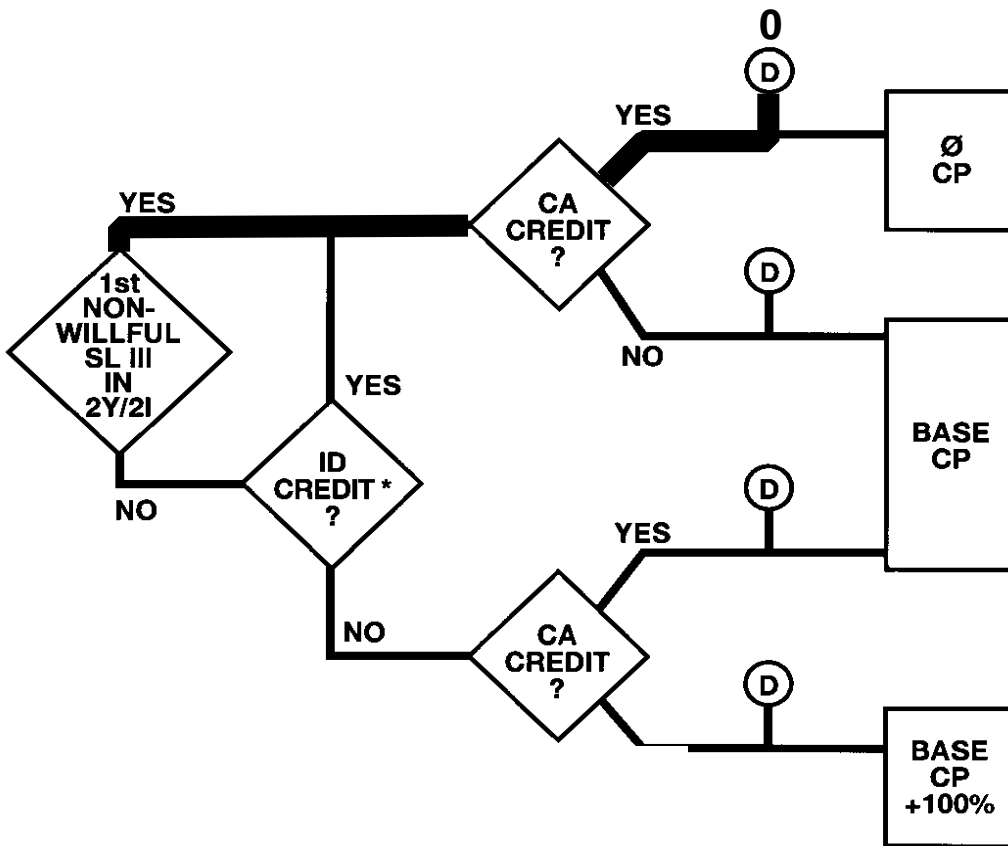

There were no items assessed on this path.

PAGE INTENTIONALLY LEFT BLANK

**FIGURE 12: CIVIL PENALTY PROCESS
PATH C**

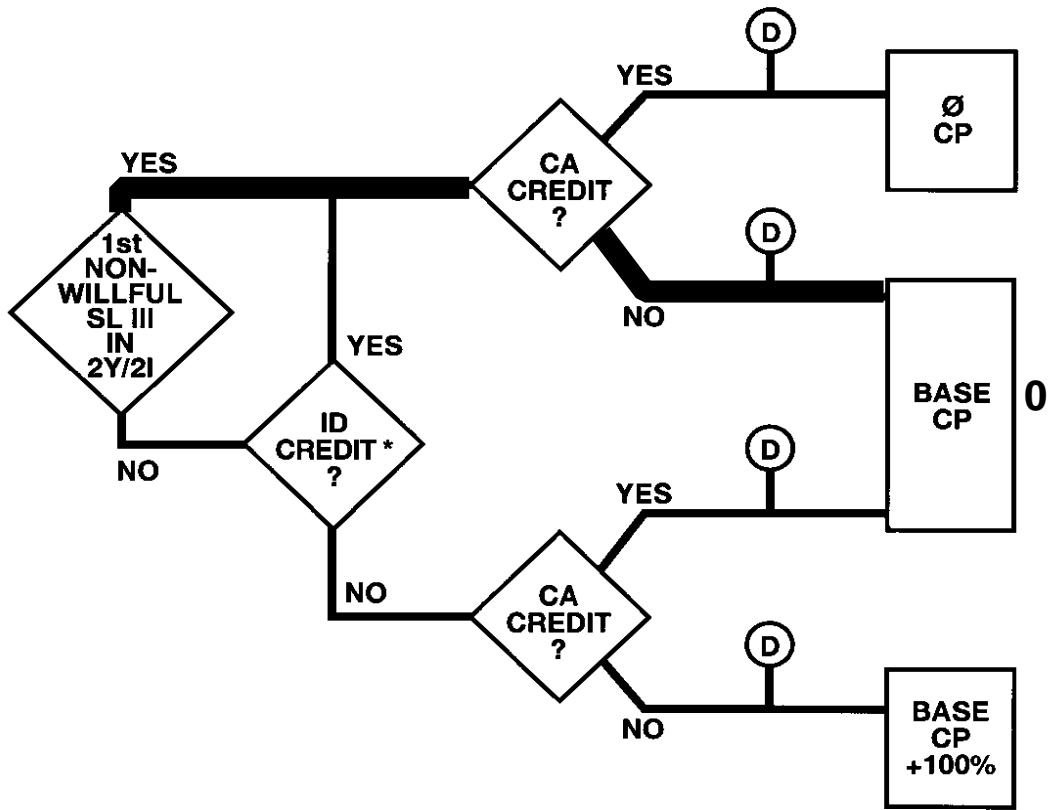

There were no items assessed on this path.

PAGE INTENTIONALLY LEFT BLANK

**FIGURE 13: CIVIL PENALTY PROCESS
PATH D**

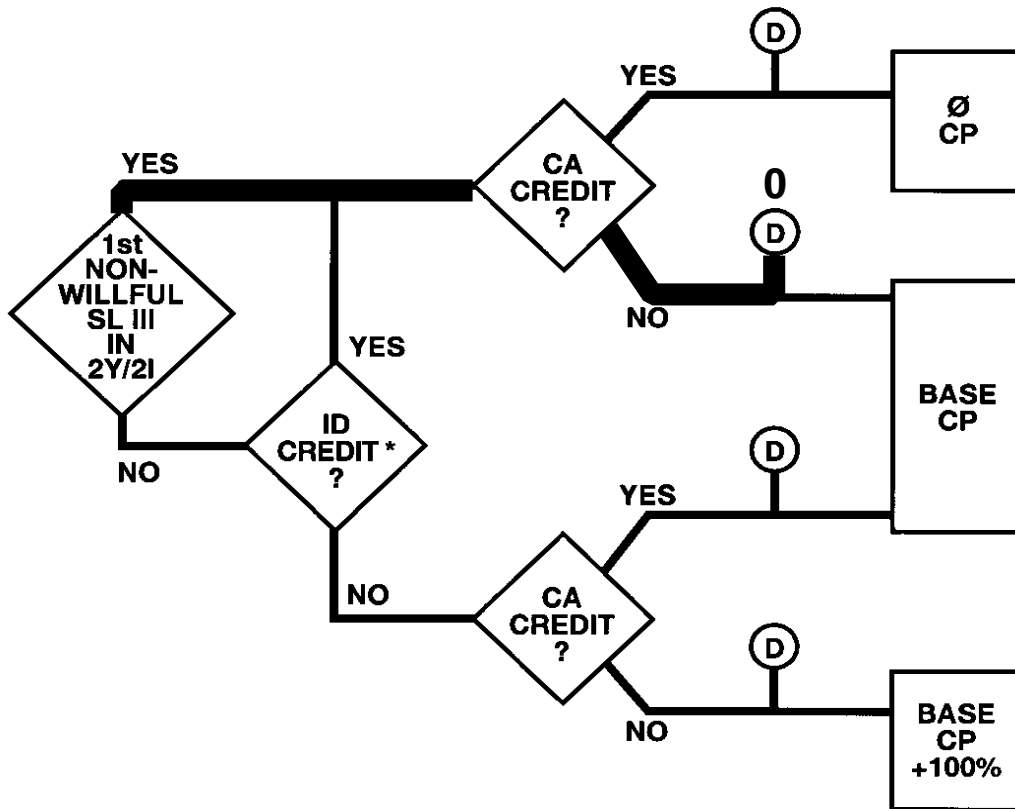

There were no items assessed on this path.

PAGE INTENTIONALLY LEFT BLANK

**FIGURE 14: CIVIL PENALTY PROCESS
PATH E**

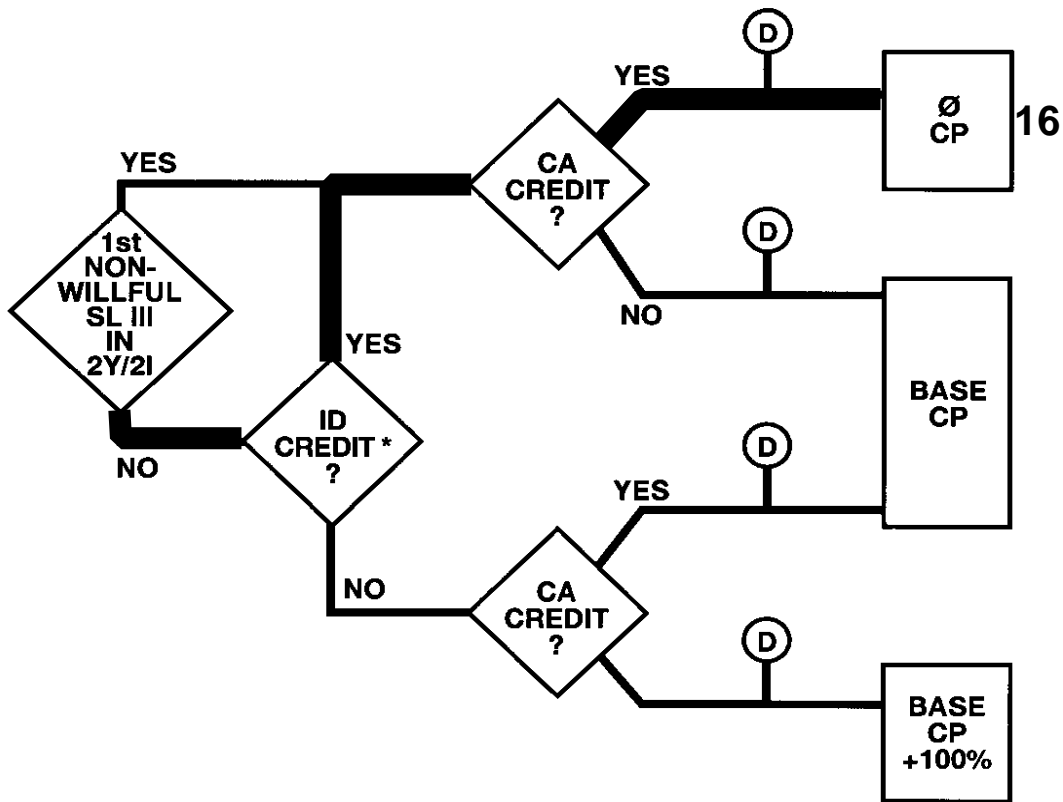

In 16 instances, the item was not the first non-willful Severity Level III enforcement issue that the licensee had during the past 2 years or past 2 inspections, the licensee received credit for actions related to identification, and the licensee received credit for corrective actions.

13 of the items were for reactor licensees.

3 of the items were for materials licensees.

PAGE INTENTIONALLY LEFT BLANK

**FIGURE 15: CIVIL PENALTY PROCESS
PATH F**

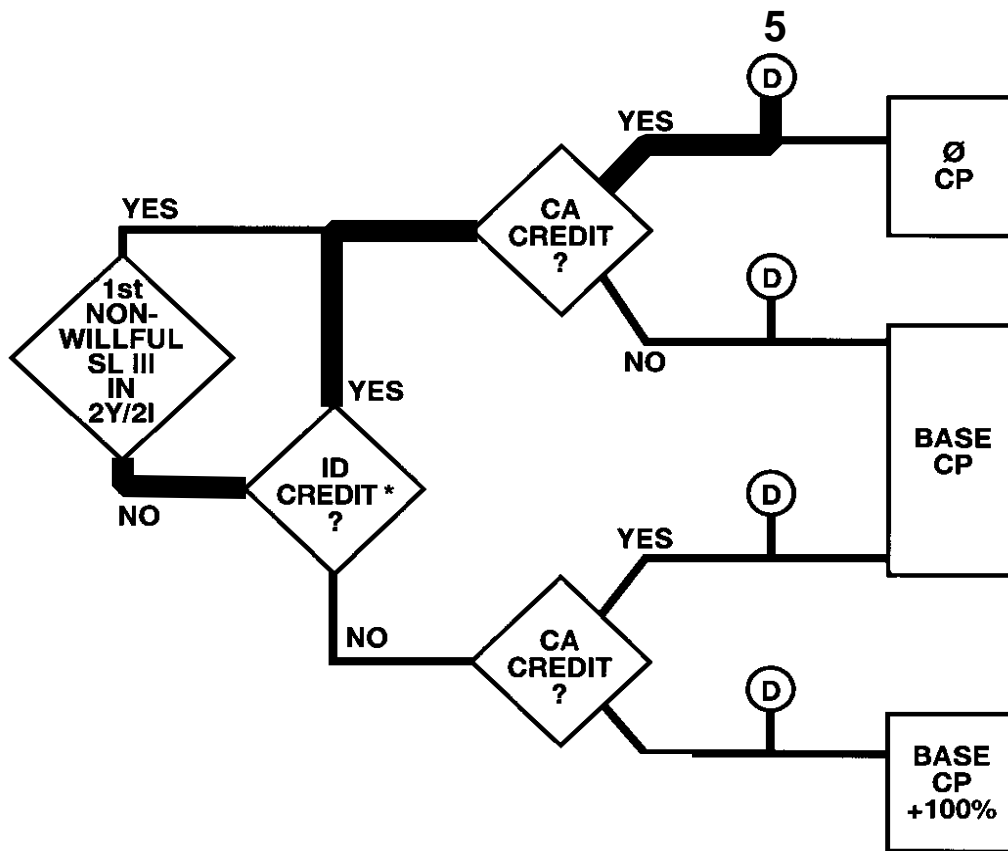

In 5 instances, the item was not the first non-willful Severity Level III enforcement issue that the licensee had during the past 2 years or past 2 inspections, the licensee received credit for actions related to identification, and notwithstanding the fact that credit was warranted for corrective actions, the NRC exercised enforcement discretion in accordance with Section VII.A.1 of the Enforcement Policy and issued a civil penalty.

1 of the items was for a reactor licensee.

4 of the items were for materials licensees.

PAGE INTENTIONALLY LEFT BLANK

**FIGURE 16: CIVIL PENALTY PROCESS
PATH G**

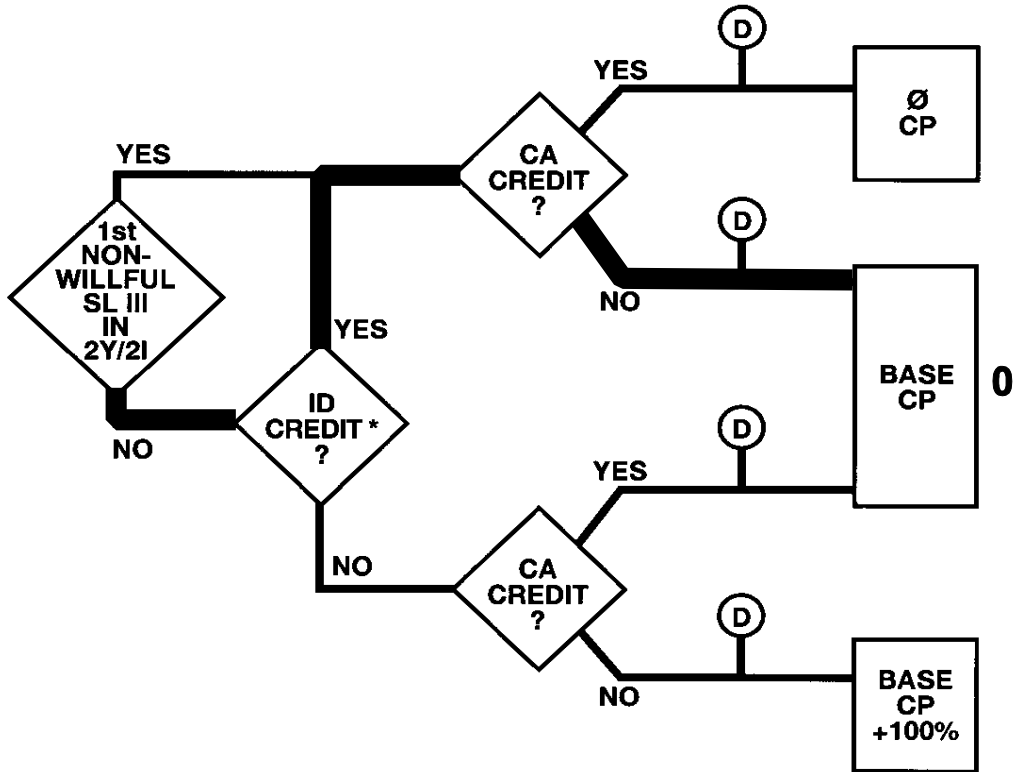

There were no items assessed on this path.

PAGE INTENTIONALLY LEFT BLANK

**FIGURE 17: CIVIL PENALTY PROCESS
PATH H**

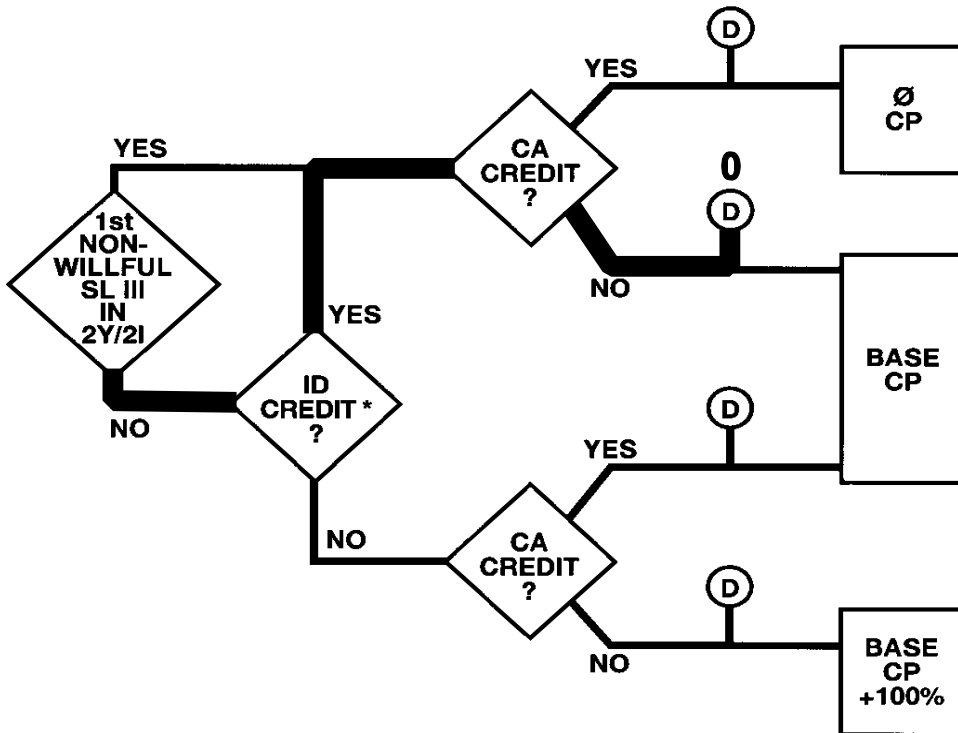

There were no items assessed on this path.

PAGE INTENTIONALLY LEFT BLANK

**FIGURE 18: CIVIL PENALTY PROCESS
PATH I**

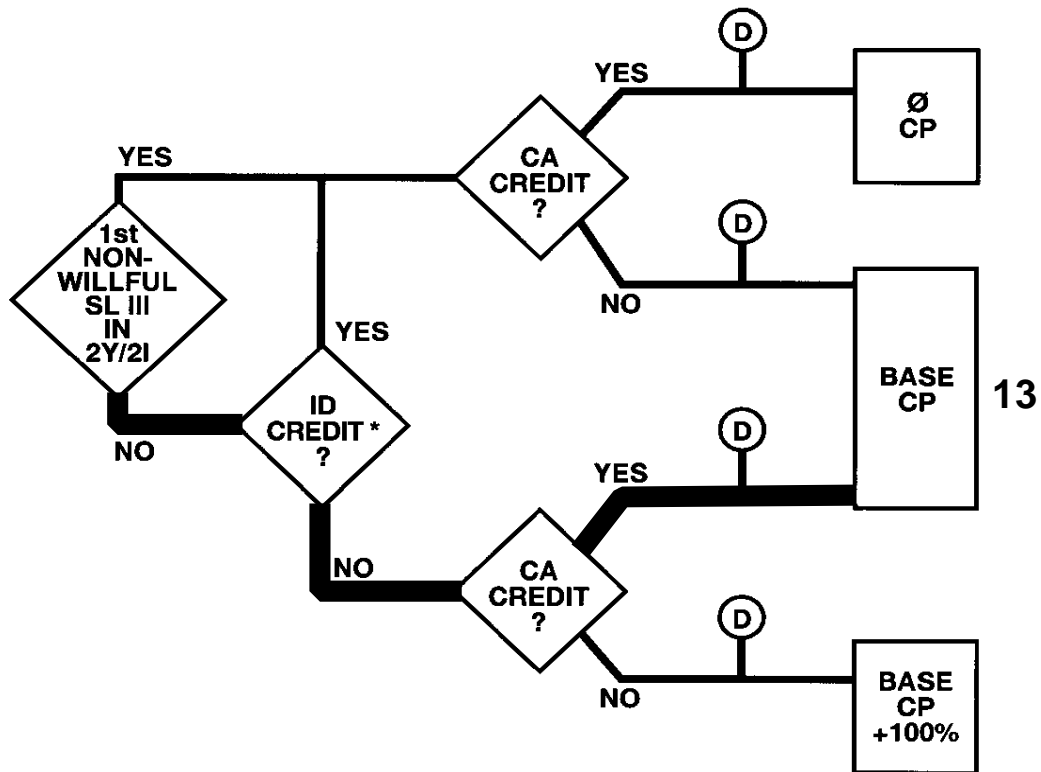

In 13 instances, the item was not the first non-willful Severity Level III enforcement issue that the licensee had during the past 2 years or past 2 inspections, the licensee did not receive credit for actions related to identification, and the licensee received credit for corrective actions.

4 of the items were for reactor licensees.

9 of the items were for materials licensees.

PAGE INTENTIONALLY LEFT BLANK

**FIGURE 19: CIVIL PENALTY PROCESS
PATH J**

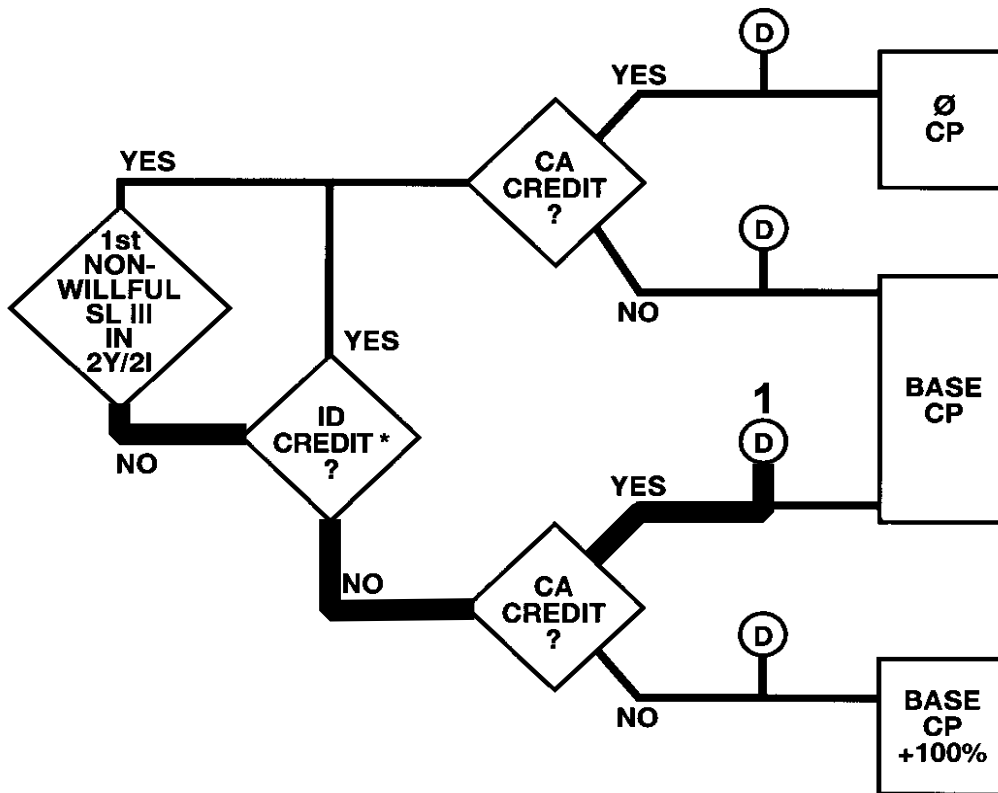

In 1 instance, the item was not the first non-willful Severity Level III enforcement issue that the licensee had during the past 2 years or past 2 inspections, the licensee did not receive credit for actions related to identification, and credit was warranted for corrective actions. Although a base civil penalty would normally be proposed, the NRC exercised discretion in accordance with Section VII.A.1 and issued twice the base civil penalty.

The 1 item was for a materials licensees.

PAGE INTENTIONALLY LEFT BLANK

**FIGURE 20: CIVIL PENALTY PROCESS
PATH K**

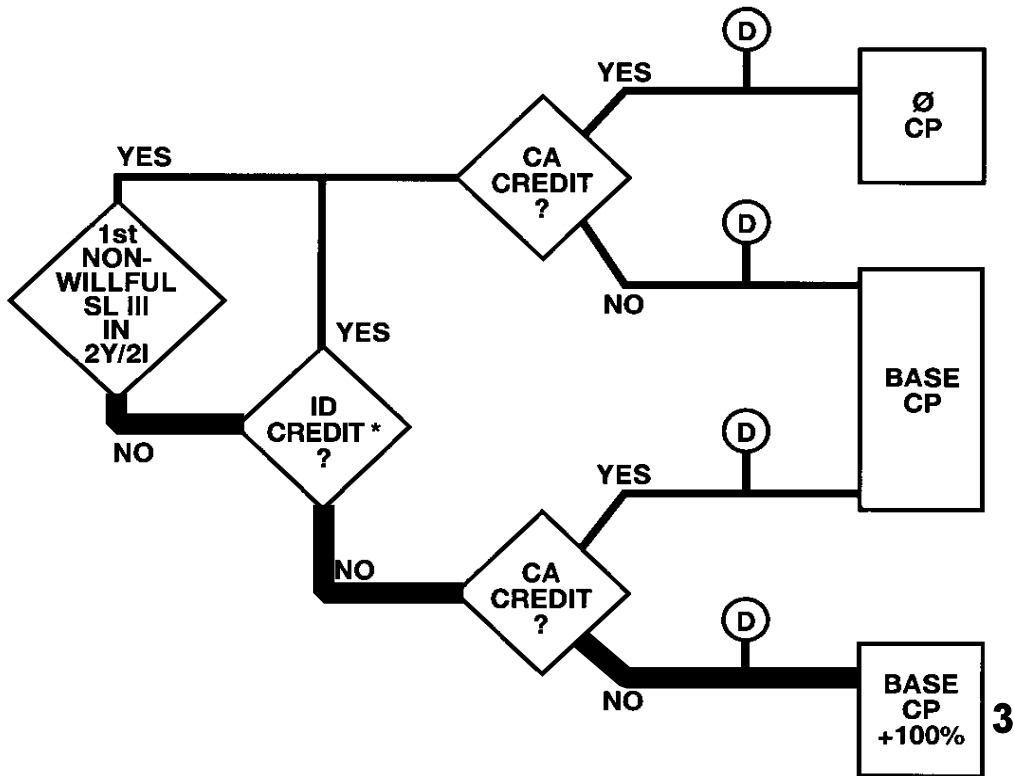

In 3 instances, the item was not the first non-willful Severity Level III enforcement issue that the licensee had during the past 2 years or past 2 inspections, the licensee did not receive credit for actions related to identification, and the licensee did not receive credit for corrective actions.

1 of the items was for a reactor licensee.

2 of the items were for materials licensees.

PAGE INTENTIONALLY LEFT BLANK

**FIGURE 21: CIVIL PENALTY PROCESS
PATH L**

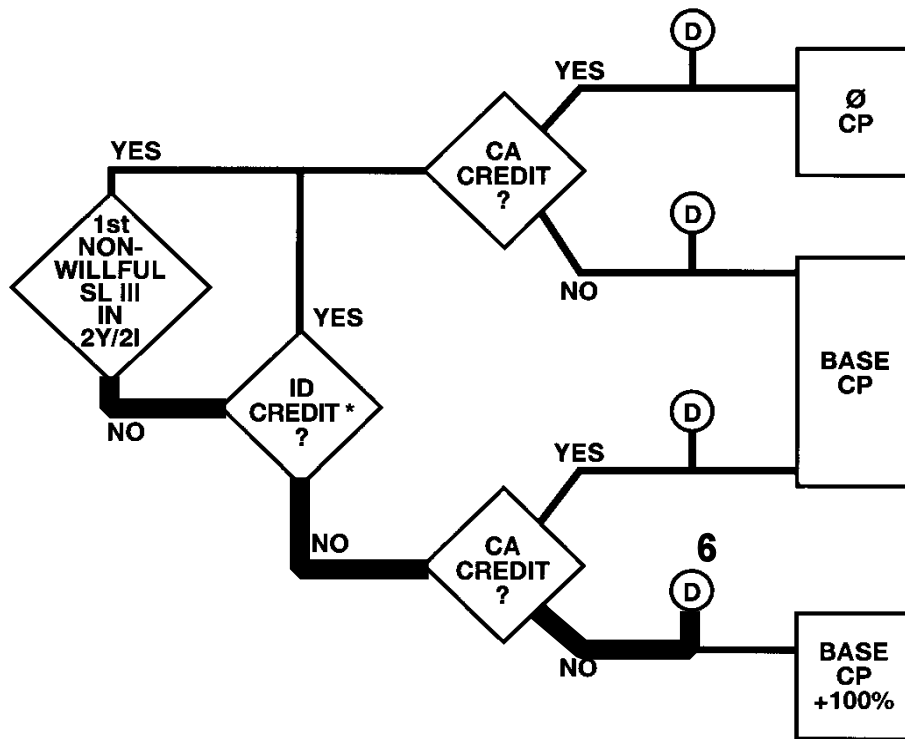

In 6 instances, the item was not the first non-willful Severity Level III enforcement issue that the licensee had during the past 2 years or past 2 inspections, the licensee did not receive credit for actions related to identification, and notwithstanding the fact that credit was not warranted for corrective actions, the NRC exercised enforcement discretion in accordance with Section VII.B.6 and Section VII.B.2 and refrained from issuing a civil penalty.

The 5 items were for reactor licensees. (5 items under VII.B.6)

PAGE INTENTIONALLY LEFT BLANK

APPENDIX A: SUMMARY OF ESCALATED NOTICES OF VIOLATION (WITHOUT CIVIL PENALTIES)

***Bill Miller, Inc., Henryetta, OK
Supplement V***

(EA 99-013)

A Notice of Violation was issued on September 24, 1999. This action was based on Severity Level III violation involving the failure to properly secure a source assembly, register as a user, and have a copy of the applicable certificate of compliance. The civil penalty was fully mitigated because the facility had not been subject to escalated enforcement within the last 2 years and because credit was warranted for corrective action.

***Commonwealth Edison Company, LaSalle
Supplement VII***

(EA 98-560)

A Notice of Violation was issued on March 29, 1999. This action was based a Severity Level III violation involving a supervisor at the LaSalle County Station that failed to follow ComEd Fitness-For-Duty (FFD) procedures on May 11, 1998, after he detected the odor of alcohol on an employee. The supervisor did not require the employee to submit to a "for-cause" FFD test, and allowed the employee to leave the station without the employee receiving the required FFD test. These actions placed ComEd in violation of its NRC required FFD procedures. Although this was not the first escalated action in 2 years, the civil penalty was fully mitigated because: (1) credit was warranted for identification and (2) credit was warranted for corrective action.

***Commonwealth Edison Company, Zion Station
Supplement III***

(EA 98-558)

A Notice of Violation was issued on April 9, 1999. This action was based on a Severity Level III violation involving the failure to maintain control of safeguards materials. Although this was not the first escalated action in 2 years, the civil penalty was fully mitigated because: (1) credit was warranted for identification and (2) credit was warranted for corrective action.

***Commonwealth Edison Company, Zion Station
Supplement III***

(EA 99-100)

A Notice of Violation was issued on July 20, 1999. This action was based on a Severity Level III violation involving the deliberate violation of the procedures implementing the NRC-approved security plan for the Zion Station. Although this was not the first escalated action in 2 years, the civil penalty was fully mitigated because: (1) credit was warranted for identification and (2) credit was warranted for corrective action.

***Connecticut Yankee Atomic Power, Haddam Neck
Supplement IV***

(EA 96-496)

A Notice of Violation was issued on April 5, 1999. This action was based on a Severity Level III problem involving a November 1996 contamination event caused by poor control of radiological activities which resulted in a plant maintenance supervisor and a contractor refueling manager becoming contaminated while performing activities in the fuel transfer canal. The violations associated created a substantial potential for exposures in excess of regulatory limits. Although a civil penalty would normally be proposed for a Severity

Appendix A

Level III problem, the NRC exercised enforcement discretion in accordance with Section VII.B.6 of the Enforcement Policy and did not propose a civil penalty for the violations given that: (1) the violations occurred prior to the licensee's decision, in December 1996, to permanently shutdown the Haddam Neck facility; and (2) the licensee was issued a \$650,000 civil penalty on May 12, 1997, to address the performance problems that existed prior to the decision to permanently shutdown the facility, and which indicated generally poor performance over a period of time.

Consumers Power Company, Palisades Nuclear Generating Plant Supplement I

(EA 98-433)

A Notice of Violation was issued on December 11, 1998. This action was based on a Severity Level III violation which involved a surveillance test that had rendered the high pressure safety injection (HPSI) system inoperable for approximately 90 minutes during the test. The test procedure prescribed a system configuration that would have resulted in a portion of HPSI flow being diverted from the cold leg injection paths to a single hot leg injection path in the event of a loss-of-coolant accident (LOCA). For a LOCA involving this hot leg injection path, enough flow could be diverted out the break to prevent both trains of HPSI from performing their safety function. Inadequate engineering, operations and Plant Review Committee oversight of a surveillance procedure revision resulted in incorporating the incorrect system configuration. Although the facility had been the subject of escalated enforcement action within the last 2 years, the civil penalty was fully mitigated because credit was warranted for identification and corrective action.

Code Services, Inc., Madison, AL Supplement VI

(EA 99-074)

A Notice of Violation was issued on December May 7, 1999. This action was based on a Severity Level III violation involving the failure to use an alarm ratemeter during the radiographic operations. Although a civil penalty would normally have been proposed (because the licensee had been subject to escalated enforcement within the past 2 years, credit was not warranted for identification, and credit was warranted for corrective action) the NRC exercised discretion in accordance with Section VII.B.6 and refrained from issuing a civil penalty. Discretion was warranted because: (1) the new management/ownership of the company had taken steps to improve staff compliance with safety requirements; (2) significant disciplinary action was taken demonstrating to the employees that this violation would not be tolerated; (3) initial corrective actions taken by the licensee in response to NASA's finding were prompt; and (4) radiographic operations directly observed by the NRC inspector in March 1999 were conducted safely and in accordance with regulatory requirements.

DAS Consult, Inc., Dublin, OH Supplement VI

(EA 98-492)

A Notice of Violation was issued on March 31, 1999. The action was based on a Severity Level II violation involving the deliberate unauthorized transfer of byproduct material. Although a civil penalty would normally be issued in this case, the NRC exercised discretion in accordance with Section VII.B.6 and refrained from issuing a civil penalty. Discretion was appropriate because the licensee suspended operation, divested itself of byproduct material, and requested termination of its license

***Department of the Interior, Bureau of Indian Affairs, Albuquerque, NM
Supplement VI***

(EA 98-471)

A Notice of Violation was issued on January 28, 1999. The action was based on a Severity Level III problem involving failures to: (1) adequately secure and restrict access to licensed materials, specifically three portable gauges; (2) store portable gauges in locked containers designed to prevent unauthorized or accidental removal of the sealed sources from their shielded positions; and (3) perform semi-annual source inventories. The civil penalty was fully mitigated because the facility had not been the subject of escalated enforcement actions within the last two inspections and because credit was warranted for corrective action.

***Department of Veterans Affairs, San Antonio, TX
Supplement VI***

(EA 98-481)

A Notice of Violation was issued on February 17, 1999. The action was based on a Severity Level III violation involving the unauthorized use of licensed material. The civil penalty was fully mitigated because the facility had not been the subject of escalated enforcement actions within the last two inspections and because credit was warranted for corrective action.

***Duke Energy Corporation, Catawba Nuclear Station
Supplement I***

(EA 99-094)

A Notice of Violation was issued on July 22, 1999. This action was based on a Severity Level III violation involving the failure to maintain the operability of the Standby Shutdown System (SSS). Although the facility had been the subject of an escalated enforcement action within the last 2 years, the civil penalty was fully mitigated because credit was warranted for identification and corrective action.

***Entergy Operations, Inc., River Bend Station
Supplement I,***

(EA 98-478)

A Notice of Violation was issued on February 1, 1999. This action was based on a Severity Level III violation involving a design deficiency that caused uncertainty as to the ability of the Division I and II Emergency Diesel Generators (EDGs) to perform their intended safety function under design basis accident conditions and rendered the EDGs incapable of complying with the technical specification definition of operability since original installation. The violation involved the licensee's failure to ensure design control measures adequately verified that the EDGs would have remained operable during certain periods of operations. Although this was not the first escalated action in 2 years, the civil penalty was fully mitigated because: (1) credit was warranted for identification and (2) credit was warranted for corrective action. A civil penalty action was also issued at the same time based on a Severity Level III violation that involved the licensee's failure to promptly identify and correct the significant condition adverse to quality that related to the operability of the EDGs. (See EA 98-478 in Appendix B.)

***Entergy Operations, Waterford-3
Supplement III***

(EA 98-479)

A Notice of Violation for a Severity Level III violation was issued on January 7, 1999. The action was based on a failure to maintain required control of a copy of the Waterford-3 Physical Security Plan. Although this was not the first escalated enforcement action within the last 2 years, the civil penalty was fully mitigated because: (1) credit was warranted for Identification and (2) credit was warranted for corrective action.

Appendix A

Entergy Operations, Inc., Waterford-3 Supplement III

(EA 99-104)

A Notice of Violation was issued on June 15, 1999. This action was based on a Severity Level III violation involving the access authorization program. Although this was not the first escalated enforcement action within the last 2 years, the civil penalty was fully mitigated because: (1) credit was warranted for Identification and (2) credit was warranted for corrective action.

Envirocare of Utah, Inc., Salt Lake City, UT Supplements IV & VI

(EA 99-168)

A Notice of Violation was issued on August 16, 1999. This action was based on a Severity Level III violation involving the failure to perform adequate surveys to ensure compliance with radiation dose limits to the public. The civil penalty was fully mitigated because the facility had not been the subject of escalated enforcement actions within the last 2 years and because credit was warranted for corrective action.

Environmental Protection Agency, Montgomery, Alabama Supplement VI

(EA 98-545)

A Notice of Violation was issued on January 15, 1999. This action was based on a Severity Level III violation involving the failure to secure licensed material. The civil penalty was fully mitigated because the facility had not been the subject of escalated enforcement actions within the last two inspections and because credit was warranted for corrective action.

First Energy Nuclear Operating Company, Davis-Besse Nuclear Power Station Supplement I

(EA 99-138)

A Notice of Violation was issued on August 6, 1999. This action was based on a Severity Level III problem involving the failure to maintain the design of a pressurizer spray valve and inadequate corrective action for the degraded condition. The civil penalty was fully mitigated because the facility had not been the subject of escalated enforcement actions within the last 2 years and because credit was warranted for corrective action.

Florida Power and Light Company, St Lucie Supplement I

(EA 98-513)

A Notice of Violation was issued on March 31, 1999. This action was based a Severity Level III violation involving a lack of fire protection procedural guidance intended to implement the alternative shutdown capability in the event of a main control room evacuation. Although the facility had been the subject of escalated enforcement action within the last 2 years, the civil penalty was fully mitigated because credit was warranted for identification and corrective action.

***Georgetown University Medical Center, Washington, DC
Supplements IV & VI***

(EA 99-231)

A Notice of Violation was issued on September 10, 1999. This action was based a Severity Level III violation involving the failure to control licensed material (11.1 curies of iridium-192). The civil penalty was fully mitigated because the facility had not been the subject of an escalated enforcement action within the last 2 years or two inspections and because credit was warranted for corrective action.

***Hartford Hospital, Hartford, CT
Supplements IV & VI***

(EA 98-575)

A Notice of Violation was issued on February 5, 1999. This action was based a Severity Level III problem involving: (1) the failure to control and maintain constant surveillance of licensed material, (2) the failure to make, or cause to be made, surveys, and (3) the failure to label contaminated waste. The civil penalty was fully mitigated because the facility had not been the subject of an escalated enforcement action within the last 2 years and because credit was warranted for corrective action.

***Howard University, Washington, DC
Supplement VI***

(EA 99-211)

A Notice of Violation was issued on September 17, 1999. This action was based a Severity Level III problem involving: (1) failure to control and maintain constant surveillance of licensed radioactive material on two occasions; (2) failure to provide required radiological safety training to certain members of the licensee's shipping and receiving and mail room staff; and (3) failure to make immediate notifications to the NRC once the material was determined to be lost on one of the occasions. The civil penalty was fully mitigated because the facility had not been the subject of an escalated enforcement action within the last 2 years or 2 inspections and because credit was warranted for corrective action.

***Illinois Power Co., Clinton
Supplement VII***

(EA 98-464)

A Notice of Violation was issued September 30, 1999. The action was based on a Severity Level III violation involving discrimination against a quality verification inspector for bringing safety concerns to the NRC. Although the violation was willful and the facility had been the subject of escalated enforcement action within the last 2 years, the civil penalty was fully mitigated because credit was warranted for identification and corrective action.

***Maine Yankee Atomic Power Company, Maine Yankee Atomic Power Station (EAs 96-299; 96-320;
Supplement I 96-397;97-034; 97-147; 97-375; 97-559)***

A Notice of Violation for a Severity Level II problem and four Severity Level III problems was issued on October 8, 1998. The Severity Level III problems were related to four broad categories, namely, the failure to: (1) adequately test equipment; (2) environmentally qualify equipment; (3) perform adequate safety reviews; and (4) either identify deficiencies, or take appropriate corrective actions in a timely manner to address known deficiencies, including design related issues. Some of the violations led to safety equipment being inoperable or degraded for extended periods contrary to technical specifications. The Severity Level II violation was based on the licensee operating the facility without having demonstrated that its ECCS systems were capable of mitigating the most severe postulated loss-of-coolant accident. Civil penalties were not proposed because: (1) Maine Yankee essentially replaced the entire management infrastructure since the

Appendix A

time these problems occurred, and the new management was effective in safely managing shutdown and decommissioning operations; (2) the fact that the Maine Yankee facility had been shutdown since December 5, 1996, was permanently retired on August 6, 1997, and the violations at issue here are not reflective of Maine Yankee's post shutdown and decommissioning performance; and, (3) unlike Haddam Neck in which a substantial civil penalty was imposed after declaring permanent retirement of the facility, Maine Yankee was not in the business of operating other nuclear power facilities.

Material Testing Consultants, Inc., Grand Rapids, MI (EA 99-107)
Supplements IV & V

A Notice of Violation was issued on June 25, 1999. The action was based on a Severity Level III problem involving the failure to control licensed material that resulted in the loss of a moisture density gauge. The civil penalty was fully mitigated because the licensee had not been subject to escalated enforcement within the last two inspections and because credit was warranted for corrective action.

Materials Testing & Inspection, Boise, ID (EA 98-527)
Supplements IV

A Notice of Violation was issued on January 28, 1999. The action was based on a Severity Level III violation involving the failure to secure licensed material from unauthorized access or removal. The civil penalty was fully mitigated because the licensee had not been subject to escalated enforcement within the last two inspections and because credit was warranted for corrective action.

Materials Testing Laboratory, Inc., New Hyde Park, NY (EA 98-437)
Supplements IV, V, & VI

A Notice of Violation was issued on November 3, 1998. The action was based on a Severity Level III problem involving: (1) failure to secure licensed material from unauthorized access or removal from a controlled or unrestricted area which resulted in a loss of a gauge from the Newington, Connecticut facility; (2) failure to review the radiation safety program content and implementation at least annually; (3) failure to perform surveys that are reasonable under the circumstances to evaluate the potential radiological hazards that could be present; (4) and (5) failure to mark and label packages containing hazardous material transported on public highways; (6) failure to train hazmat employees; (7) failure to maintain possession limits for materials under NRC jurisdiction below 750 millicuries of americium-241; and (8) failure to maintain records required by the license at the New York office as stated in the correspondence dated November 29, 1996. The civil penalty was fully mitigated because the licensee had not been subject to escalated enforcement within the last two inspections and because credit was warranted for corrective action.

Medi-Physics, Inc., Livingston, NJ (EA 99-093)
Supplements IV & VI

A Notice of Violation was issued on June 17, 1999. The action was based on a Severity Level III problem involving the transportation of radioactive materials without the use of proper packaging or labeling. The civil penalty was fully mitigated because the licensee had not been subject to escalated enforcement within the last 2 years and because credit was warranted for corrective action.

***Metorex, Inc., Ewing, NJ
Supplements VI & VII***

(EA 99-043)

A Notice of Violation was issued on August 19, 1999. The action was based on a Severity Level III problem involving unauthorized transfer of radioactive material and deliberate failure to submit required reports. Although the violations were willful, the civil penalty was fully mitigated because credit was warranted for identification and corrective action.

***Niagra Mohawk Power Corporation, Nine Mile Point Nuclear Power Plant
Supplement I***

(EA 99-010)

A Notice of Violation was issued on June 29, 1999. This action was based on a Severity Level III violation involving the failure to comply with technical specification requirements for required control room staffing. Although the facility had been the subject of escalated enforcement action within the last 2 years, the civil penalty was fully mitigated because credit was warranted for identification and corrective action.

***Northeast Nuclear Energy Company (NNECo), Millstone Unit 1
Supplement I***

(EA 96-151)

A Notice of Violation for a Severity Level III problem was issued on May 25, 1999. This action was based on four violations of NRC requirements related to the careless disregard of NRC requirements in which the licensee: (1) performed both partial and full core reactor fuel offloads prior to the decay times assumed in the FSAR without the appropriate engineering analyses; (2) utilized unapproved and unanalyzed system configurations to augment spent fuel pool (SFP) cooling during refueling outages, without procedures to govern those activities; and (3) in two instances submitted incomplete and inaccurate information to the NRC related to the performance of fuel offloads that were actually being commenced before the delay times assumed in the analyses submitted to the NRC. A civil penalty was not issued in this case because the violations were outside the 5-year statute of limitations.

***Northeast Nuclear Energy Company (NNECo), Millstone Unit 1
Supplement VI***

(EA 98-325)

A Notice of Violation was issued on April 6, 1999. This action was based on three Severity Level II violations related to discrimination of plant employees. The NRC concluded that discrimination occurred in two OI Cases. OI Case No.1-96-002 involved two supervisors demoted as a result of a 1993 reorganization. A Supervisor in the Performance Engineering group engaged in protected activities with regard to check valve operability issues and his active support of another Millstone employee who had raised safety concerns about spent fuel off-loading practices at Millstone. These protected activities were a contributing factor in his demotion and was thus, discrimination which is prohibited by 10 CFR 50.7. A Supervisor in the Engineering Mechanics group engaged in protected activities with regard to the safety-related motor-operated valve program, heat exchanger issues, and reactor coolant pump maintenance problems at Millstone. The protected activities were a contributing factor in removal of his responsibilities and in a demotion and thus, was discrimination prohibited by 10 CFR 50.7. With regard to OI Case No. 1-97-007 a Supervisor, Electrical Engineering at Millstone Unit 2 in August 1995, was dismissed after reporting to higher-level management and the Millstone Nuclear Safety Concerns Program that his immediate superior had threatened him and another employee with dismissal if a system modification was not completed before the scheduled conclusion of a Millstone Unit 2 refueling outage. The NRC concluded that the Electrical Engineering Supervisor's protected activity was a contributing factor in his dismissal and that the dismissal was thus, discrimination which is prohibited by 10 CFR 50.7. In recognition of the fact that the

Appendix A

Licensee had taken substantial actions to address and correct the general and widespread employee concerns and discrimination problems that existed at the time of the violations, the NRC exercised discretion pursuant to the special circumstances provisions of Section VII.B.6 of the Enforcement Policy and refrained from issuing civil penalties in this case.

Northeast Nuclear Energy Company (NNECO), Millstone Unit 2 Supplement I

(EA 98-468)

A Notice of Violation for a Severity Level III violation was issued on February 18, 1999. The action was based on a violation that involved a change to the facility made in 1995, with respect to the Auxiliary Feedwater (AFW) system, without first performing a safety evaluation to ensure that the change did not involve an unreviewed safety question. Although a civil penalty is normally considered for a Severity Level III violation, the NRC exercised discretion in accordance with Section VII.B.2 of the Enforcement Policy and refrained from proposing a civil penalty in this case. The decision to exercise discretion was made because: (1) the violation occurred before the extended shutdown of the Millstone units and was considered an additional example of the underlying performance problems that were the basis for the \$2,100,000 civil penalty issued to NNECO on December 12, 1997; (2) the violation was not willful; and (3) the decision to restart Millstone Unit 2 required NRC's concurrence. Although the violation was identified by the NRC, the NRC concluded that a civil penalty in this case was not necessary to achieve remedial action.

North Country Hospital and Health Center, Inc., Newport, VT Supplement VI

(EA 99-153)

A Notice of Violation was issued on July 20, 1999. The action was based on a Severity Level III problem including multiple violations involving a misadministration, including the failure to notify the NRC. The civil penalty was fully mitigated because the licensee had not been the subject of escalated enforcement action within the last 2 years or 2 inspections and credit was warranted for corrective action. The civil penalty was fully mitigated because the licensee had not been the subject of escalated enforcement action within the last 2 years and credit was warranted for corrective action.

Nuclear Pharmacy of Idaho, Inc., Boise, ID Supplement IV

(EA 98-363)

A Notice of Violation was issued on October 19, 1998. The action was based on a Severity Level III problem including failures to: (1) perform an evaluation to determine the dose to the skin of the right forearm of the individual involved in the contamination event; (2) limit to 50 rems the annual shallow-dose equivalent to the skin of the individual involved in the contamination event (the individual received an estimated shallow dose equivalent of 115 rems to the skin); and (3) submit a written report within 30 days following the contamination event. The civil penalty was fully mitigated because the licensee had not been the subject of escalated enforcement action within the last 2 years or 2 inspections and credit was warranted for corrective action.

***Philadelphia Health and Education Corp., Philadelphia, PA
Supplement VI***

(EA 99-096)

A Notice of Violation was issued on May 11, 1999. The action was based on a Severity Level III violation involving the unauthorized use of licensed material. The civil penalty was fully mitigated because the licensee had not been the subject of escalated enforcement action within the last 2 years or 2 inspections and credit was warranted for corrective action.

***Saint Clare's Hospital, Dover, NJ
Supplement VI***

(EA 99-210)

A Notice of Violation was issued on May 11, 1999. The action was based on a Severity Level III problem involving: (1) failure to survey (2) failure to maintain control and surveillance of licensed material, and (3) failure to report loss of material to NRC. The civil penalty was fully mitigated because the licensee had not been the subject of escalated enforcement action within the last 2 years or 2 inspections and credit was warranted for corrective action.

***SibTech, Inc., Elmsford, NY
Supplement VI***

(EA 99-123)

A Notice of Violation was issued on May 21, 1999. The action was based on a Severity Level III violation involving the unauthorized possession and transfer of byproduct material. The civil penalty was fully mitigated because the licensee had not been the subject of escalated enforcement action within the last 2 years or 2 inspections and credit was warranted for corrective action.

***Sinai Hospital, Detroit, MI
Supplement VI***

(EA 98-523)

A Notice of violation was issued on December 18, 1998. The action was based on a Severity level III problem involving a cobalt-60 teletherapy misadministration. The violations involved: (1) failure to assure that the treatment was in accordance with the written directive by checking dose calculations within three working days of initiation of treatment, (2) failure of the treating therapists to compare the written directive with the calculations each day of treatment, and (3) failure of the staff to perform weekly chart checks to verify treatment parameters were in accordance with the written directive. The civil penalty was fully mitigated because the licensee had not been the subject of escalated enforcement action within the last 2 years or 2 inspections and credit was warranted for corrective action.

***Southern California Edison Co., San Onofre Nuclear Generating Station
Supplement I***

(EA 98-563)

A Notice of Violation was issued on March 16, 1999. This action was based a Severity Level III violation involving the failure to maintain the emergency chilled water system operable in accordance with technical specifications. Although the licensee had been the subject of escalated enforcement action within the last 2 years, the civil penalty was fully mitigated because credit was warranted for identification and corrective action.

Appendix A***Southern Processing Enterprises, Beaver, WV
Supplement VI******(EA 98-495)***

A Notice of Violation was issued on October 30, 1998. This action was based a Severity Level III problem the removal and unauthorized transfer of generally licensed gauges. The civil penalty was fully mitigated because the licensee had not been the subject of escalated enforcement action within the last 2 years or 2 inspections and credit was warranted for corrective action.

***Triad Engineering, Inc., Morgantown, WVA
Supplement VI******(EA 99-134)***

A Notice of Violation was issued on July 8, 1999. The action was based on a Severity Level III violation involving the failure to secure and control licensed material (moisture density gauge). The civil penalty was fully mitigated because the facility had not been subject to escalated enforcement within the last two inspections and because credit was warranted for corrective action.

***Tulsa Gamma Ray, Inc., Tulsa, OK
Supplement IV******(EA 98-475)***

A Notice of Violation was issued on February 25, 1999. The action was based on a Severity Level III violation involving two radiation exposures in excess of NRC limits. The civil penalty was fully mitigated because the facility had not been subject to escalated enforcement within the last two inspections and because credit was warranted for corrective action.

***University of Medicine and Dentistry of New Jersey, Newark, NJ
Supplement IV******(EA 98-536)***

A Notice of Violation was issued on December 29, 1998. The action was based on a Severity Level III violation involving the failure to secure licensed materials in an unrestricted area. The civil penalty was fully mitigated because the facility had not been subject to escalated enforcement within the last 2 years and because credit was warranted for corrective action.

***U.S. Enrichment Corporation, Paducah, KY
Supplement VI******(EA 99-016)***

A Notice of Violation was issued on Mach 5, 1999. The action was based on a Severity Level III violation involving the failure to maintain control of classified matter at the Paducah facility. Although this was not the first escalated enforcement action within the last 2 years, the civil penalty was fully mitigated because: (1) credit was warranted for identification, and (2) credit was warranted for corrective action.

***Washington Public Power Supply System, WNP-2
Supplement I******(EA 98-480)***

A Notice of Violation was issued on January 11, 1999. The action was based on for a Severity Level III violation involving the failure to assure that a rupture of the plant's fire main would not impair equipment important to safety. Although this was not the first escalated enforcement action within the last 2 years, the civil penalty was fully mitigated because: (1) credit was warranted for identification, and (2) credit was warranted for corrective action.

***Wisconsin Electric Power (WEPCo), Point Beach
Supplement I***

(EA 99-002)

A Notice of Violation was issued on April 28, 1999. This action was based a Severity Level III violation involving the ice blockage of the minimum flow recirculation line for two safety injection (SI) pumps. The civil penalty was fully mitigated in this case because the licensee had not been the subject of escalated enforcement actions within the last 2 years and credit for corrective action was warranted.

***XRI Testing, Troy, MI
Supplement VI***

(EA 98-507)

A Notice of Violation was issued on February 25, 1999. This action was based a Severity Level II problem involving: (1) failure of a radiographer to wear an alarming ratemeter, (2) failure to have two qualified individuals present during radiographic operations, (3) failure to maintain continuous direct visual surveillance of radiographic operations, and (4) failure to conduct a survey of the device or the guide tube prior to manipulating the collimator, which resulted in a significant radiation exposure to the radiographer's hand. Although the violation was willful, the civil penalty was fully mitigated because credit was warranted for identification and corrective action.

PAGE INTENTIONALLY LEFT BLANK

APPENDIX B: SUMMARY OF PROPOSED CIVIL PENALTIES

***Anvil Corporation, Bellingham, WA
Supplements IV & VI***

(EA 99-083)

A Notice of Violation and Proposed Imposition of Civil Penalty in the amount of \$8,800 was issued on June 28, 1999. This action was based on a Severity Level II problem that involved multiple failures to maintain occupational radiation doses, supervise radiographic operations, perform surveys, and wear an operating alarm ratemeter. Although full mitigation would normally be considered appropriate in this case (because credit was warranted for identification and corrective action), the NRC exercised discretion and proposed twice the base civil penalty in accordance with Section VII.A.1. Discretion was warranted because of the significance which NRC assigns to radiation doses in excess of NRC limits which were preventable by basic radiation safety practices.

***Arizona Public Service Company, Palo Verde Nuclear Generating Station
Supplement I***

(EA 98-382)

A Notice of Violation and Proposed Imposition of Civil Penalty in the amount of \$55,000 was issued on December 21, 1998, to Arizona Public Service Company. This action was based on a Severity Level III problem which involved the degraded performance capability of the High Pressure Safety Injection (HPSI) system for certain accident conditions due to incorrectly assembled check valves that would have resulted in a decrease in flow to the reactor vessel significantly below the flow assumed in the safety analysis. This condition existed for approximately 6 years in Unit 1, 5 years in Unit 2, and 1½ years in Unit 3. The Severity Level III problem consisted of three violations that involved: (1) failures to adhere to technical specification limiting conditions for operation when ECCS subsystems were inoperable; (2) a failure to identify and correct significant conditions adverse to quality despite numerous indicators; and (3) inadequate procedures which caused the problems and prevented timely identification of the significant conditions adverse to quality. A base civil penalty was proposed for the Severity Level III problem because: (1) this was not the first escalated action in 2 years, (2) credit was not warranted for identification, and (3) credit was warranted for corrective action.

***Baxter Healthcare Corporation, Albonito, PR
Supplement VI***

(EA 97-518)

A Notice of Violation and Proposed Imposition of Civil Penalties in the amount of \$10,500 was issued on October 9, 1998, for two Severity Level III violations. The first violation was based on willful, unauthorized bypassing of a safety system interlock on an irradiator. Twice the base civil penalty (\$5,000) was proposed in this case because: (1) the violation was considered willful, (2) credit was not warranted for identification, and (3) credit was not warranted for corrective action. The second violation was based on three additional examples where the licensee conducted subsequent, unauthorized repairs to equipment affecting the irradiator control console's "on-off" mechanism. Although a base civil penalty would normally be considered appropriate in this case (because the violation was considered willful, credit was not warranted for identification, and credit was warranted for corrective action), the NRC exercised discretion and proposed twice the base civil penalty in accordance with Section VII.A.1 (\$5,500). Discretion was warranted due to the verbal and written notice the NRC gave to the licensee regarding the specific requirements of its license.

Appendix B***Coriell Institute for Medical Research, Camden, NJ
Supplement VII******(EA 99-060)***

A Notice of Violation and Proposed Imposition of Civil Penalty in the amount of \$4,400 was issued on June 2, 1999, for a Severity Level II violation. The action was based on discrimination against an employee for raising safety concern. Specifically, a laboratory technician raised a safety concern regarding unnecessary exposure to employees from phosphorus-32, in a Coriell laboratory on September 13, 1996. A base civil penalty was proposed in this case because: (1) the violation was considered willful, (2) credit was not warranted for identification, and (3) credit was warranted for corrective action.

***Deleo, Alfonso Jr., Ardmore, PA
Supplement VI******(EA 99-057)***

A Notice of Violation and proposed imposition of Civil Penalty in the amount of \$5,500 was issued on June 2, 1999, for a Severity Level III violation. This action was based on willful, unauthorized possession of nuclear gauges. Twice the base civil penalty was proposed in this case because: (1) the violation was considered willful, (2) credit was not warranted for identification, and (3) credit was not warranted for corrective action.

***Deleo, Alfonso Jr., Ardmore, PA
Supplement VI******(EA 99-217)***

A Notice of Violation and proposed imposition of Civil Penalty in the amount of \$15,000 was issued on August 23, 1999, for a Severity Level III violation. This action was based on the continuing willful, unauthorized possession of nuclear gauges (See EA 99-057). The NRC proposed additional civil penalties in the amount of \$15,000 (\$500 a day for the period from July 12 through August 11, 1999).

***DMS Imaging, Inc., Bemidji, MN
Supplement VI & VII******(EA 97-189)***

A Notice of Violation and proposed imposition of Civil Penalty in the amount of \$2,500 was issued on February 24, 1999, for a Severity Level III violation. This action was based on failure to wear personnel monitoring devices at all times while in areas where radioactive materials are used or stored and failure to provide complete and accurate information to an NRC investigator. A base civil penalty was proposed in this case because: (1) the violation was considered willful, (2) credit was not warranted for identification, and (3) credit was warranted for corrective action.

***Entergy Operations, River Bend Station
Supplement VII******(EA 98-132)***

A Notice of Violation and proposed imposition of Civil Penalty in the amount of \$55,000 was issued on January 5, 1999, for a Severity Level III violation. This action was based on the deliberate failure to provide the NRC with information that was complete and accurate in all material respects, in violation of 10 CFR 50.9. Specifically, the violation involved deliberate misconduct by a licensee manager, the Superintendent of Radiation Control, when he provided an NRC senior resident inspector with information he knew was not accurate and not complete during a meeting on October 15, 1997. During that meeting, the Superintendent of Radiation Control showed the senior resident inspector four Radiation Work Permits (RWPs) that a technician signed onto during the period October 10-15, 1997 and stated that none of the RWPs, were violated because none of the RWPs required "minimum booties and gloves;" instead the RWPs

allowed a technician to determine the protective clothing requirements. However, the Superintendent did not present the version of RWP 97-0002 that had been in effect on October 10, 1997. A base civil penalty was proposed in this case because: (1) the violation was considered willful, (2) credit was not warranted for identification, and (3) credit was warranted for corrective action.

***Entergy Operations, River Bend Station
Supplement I,***

(EA 98-478)

A Notice of Violation and Proposed Imposition of Civil Penalty in the amount of \$55,000 was issued on February 1, 1999. This action was based on a Severity Level III violation involving a design deficiency that caused uncertainty as to the ability of the Division I and II Emergency Diesel Generators (EDGs) to perform their intended safety function under design basis accident conditions and rendered the EDGs incapable of complying with the technical specification definition of operability since original installation. The violation involved the licensee's failure to promptly identify and correct the significant condition adverse to quality that related to the operability of the EDGs. The NRC considered that credit for identification was not warranted for this violation. The licensee's staff had information at hand since 1990 that should have reasonably led them to recognize the design vulnerability, but its staff failed to recognize the significance of that information until June 1998 after the NRC had raised general questions relative to the integrity of the particular EDG subsystem involved. As a result, a base civil penalty was proposed for this violation because: (1) this was not the first escalated action in 2 years, (2) credit was not warranted for identification, and (3) credit was warranted for corrective action. A Notice of Violation was also issued at the same time based on a Severity Level III violation for the licensee's failure to ensure design control measures adequately verified that the EDGs would have remained operable during certain periods of operations. (See EA 98-478 in Appendix A.)

***FirstEnergy Nuclear Operating Company, Perry Nuclear Power Plant
Supplement VII***

(EA 99-012)

A Notice of Violation and Proposed Imposition of Civil Penalty in the amount of \$110,000 was issued on May 20, 1999. This action was based on a Severity Level II violation involving an investigation completed by the NRC Office of Investigations (OI) at the Perry Nuclear Power Plant owned by Centerior Energy Corporation (now FirstEnergy Nuclear Operating Company (FENOC)) on December 10, 1998. OI conducted the investigation to determine whether a Radiation Protection Supervisor (RPS) at the Perry facility was discriminated against for providing testimony as a witness in a hearing concerning another employee. Based upon the evidence developed, OI determined that the Perry Radiation Protection Manager (RPM) discriminated against a RPS for engaging in protected activities within the scope of 10 CFR 50.7. The RPS's protected activities pertained to a July 17, 1997, deposition that the RPS was to give in a Department of Labor (DOL) hearing concerning alleged employment discrimination against another individual at the Perry facility. The RPS had previously suggested to Centerior Energy representatives that his testimony would not be favorable to the Centerior Energy Corporation. The discrimination against the RPS consisted of a July 16, 1997, verbal counseling and the placement of a July 17, 1997, memorandum documenting the verbal counseling in the RPS's section personnel file on July 22, 1997. This violation was a very significant concern because it involved employee discrimination by the RPM, a mid-level facility manager, against an employee for testifying in a DOL proceeding. Such testimony is a protected activity in the Commission's employee protection regulations. Furthermore, the sphere of influence of the RPM is broad. Discrimination committed at this level had the potential to create a chilling effect throughout the Radiation Protection Department and could influence individuals in other plant departments. Twice the base civil penalty (\$176,000) was warranted for this violation because: (1) this was not the first escalated action in 2 years, (2) credit was not warranted for identification, and (3) credit was not warranted for corrective action. However a civil penalty

Appendix B

in the amount of \$110,000 was proposed because the NRC's statutory authority limits the amount of a civil penalty to \$110,000 per violation per day.

***Indiana Michigan Power Company, Donald C. Cook
Supplement I***

(EA 98-150)

A Notice of Violation and Proposed Imposition of Civil Penalties in the amount of \$500,000 was issued on October 13, 1998, for a Severity Level II problem consisting of 37 violations. The violations stemmed from the breakdown in the control of activities that led to the material degradation of multiple systems, including the ice condensers, at the Donald C. Cook units. In accordance with Section VII.A.1 of the Enforcement Policy, discretion was exercised and a \$500,000 civil penalty was issued to reflect the consideration of the particularly poor licensee performance, the duration of the problems, the impact on ECCS and containment, and the NRC's concerns regarding the violations.

***International Radiography & Inspection
Supplements IV & VI***

(EA 98-565 & EA 99-090)

A Notice of Violation and Proposed Imposition of Civil Penalties in the amount of \$17,600 was issued on May 4, 1999, for two Severity Level II problems. The action was based on multiple willful violations including, failing to limit an occupational exposure to NRC limits, failing to have a radiation survey instrument and to conduct radiation surveys at a job site where radiography was being conducted, failing to utilize personnel radiation monitoring equipment, failing to stop radiography and contact the radiation safety officer when the incident occurred, and failing to complete and maintain required records. Although the civil penalties would normally have been fully mitigated (because the licensee identified and corrected the violations), the NRC exercised discretion in accordance with Section VII.A.1 and issued twice the base civil penalties (\$8,800) for each Severity Level II problem because of the willfulness and total disregard for safety.

***Marshall Miller & Associates
Supplement VI***

(EA 97-444 & EA 98-313)

A Notice of Violation and Proposed Imposition of Civil Penalties in the amount of \$8,800 was issued on January 29, 1998, for two Severity Level II problems. The action was based on multiple failures to adhere to safety and regulatory barriers involving a 125-millicurie cesium 137 well logging source, and failure to provide NRC with complete and accurate information involving training records and radiation survey and utilization records. Base civil penalties (\$4,400) were proposed for each Severity Level II problem because: (1) the violations were considered willful, (2) credit was not warranted for identification, and (3) credit was warranted for corrective action.

***Materials Testing Laboratory Inc., New Hyde Park, NY
Supplement VI***

(EA 99-037)

A Notice of Violation and Proposed Imposition of Civil Penalty in the amount of \$2,750 was issued on June 17, 1999, for a Severity Level III problem. The action was based on the deliberate failure to allow use of a nuclear gauge without proper certification and dosimetry. A base civil penalty was proposed for the Severity Level III problem because: (1) the violations were considered willful, (2) credit was not warranted for identification, and (3) credit was warranted for corrective action.

***Myers, Allan A. Inc., Worcester, PA
Supplements VI & VII******(EA 99-042)***

A Notice of Violation and Proposed Imposition of Civil Penalty in the amount of \$2,750 was issued on July 13, 1999, for a Severity Level III problem. The action was based on three willful violations involving (1) use of a portable gauge by an unauthorized individual (2) use of a gauge without dosimetry, and (3) failure to maintain control and surveillance of gauge. A base civil penalty was proposed for the Severity Level III problem because: (1) the violations were considered willful, (2) credit was not warranted for identification, and (3) credit was warranted for corrective action.

***North Atlantic Energy Service Corporation (NAESCO), Seabrook Station
Supplement VII******(EA 98-165)***

A Notice of Violation and Proposed Imposition of Civil Penalty in the amount of \$55,000 was issued on August 3, 1999. This action was based on Severity Level III violation of NRC requirements involving discrimination by Williams Power Corporation (WPC), a contractor of NAESCO, against an electrician for raising safety issues. A base civil penalty was proposed for this violation because: (1) this was a willful violation, (2) credit was not warranted for identification, and (3) credit was warranted for corrective action.

***Northeast Nuclear Energy Company (NNECo), Millstone
Supplement I,******(EA 97-461)***

A Notice of Violation and Proposed Imposition of Civil Penalty in the amount of \$88,000 was issued on March 9, 1999. This action was based a Severity Level II violation involving the termination of two contractor employees involved in the Motor Operated Valve (MOV) department as retaliation for engaging in protected activities. An OI investigation confirmed those findings, noting that the terminations of the two contractor employees constituted discrimination. The termination of the employment of the two contractor employees occurred in August 1997, after the two individuals had raised concerns about the MOV program manual and the process by which the manual was being reviewed. The terminations were recommended by the then MOV Supervisor, and were supported by the then MOV Manager, both of whom were also contractor employees. Further, the recommendation was neither questioned nor objected to by the Recovery Officer involved with management oversight of the MOV program activities, after the MOV Manager briefed him on the recommendation, nor was it questioned by other Departments within NNECo, including the Contracts or Legal Departments during their reviews. Although full mitigation was considered because credit was warranted for identification and corrective action, the NRC exercised discretion in accordance with Section VII.A.1 of the Enforcement Policy and proposed a base civil penalty. Discretion was warranted in this case, particularly given: (1) the failures by the responsible Recovery Officer and the Contracts and Legal Departments to question the basis for the proposed terminations, despite the opportunities to do so; (2) the failures by senior management in not identifying the management problems in the MOV Department in sufficient time to prevent the terminations, and in being slow in recognizing and responding to the indications of retaliation, as noted in the Little Harbor report; (3) the failure by management to provide training to its contractor supervisors relating to the NRC's employee protection regulation, notwithstanding the Commission's Order dated October 24, 1996, concerning the need to address actions involving a lack of a safety conscious work environment, and to ensure that employees can raise safety concerns without fear of retaliation; and (4) the past history of discrimination violations involving the Millstone station, as evidenced by the three discrimination civil penalties issued between 1993 and 1996.

Appendix B

Testing Engineers & Consultants, Troy, MI Supplement IV

(EA 99-097 & EA 99-169)

A Notice of Violation and Proposed Imposition of Civil Penalties in the amount of \$5,500 was issued on July 8, 1999. This action was based on two willful Severity Level III violations involving the failure to secure and control licensed material and the failure to provide the NRC with complete and accurate information regarding the licensed material (moisture density gauge). Base civil penalties (\$2,750) were warranted for each Severity Level III violation because: (1) the violations were willful, (2) credit was not warranted for identification, and (3) credit was warranted for corrective action.

U.S. Enrichment Corporation, Portsmouth, OH Supplement VIII

(EA 99-080)

A Notice of Violation and Proposed Imposition of Civil Penalty in the amount of \$55,000 was issued on June 29, 1999. This action was based on Severity Level III violation involving the failure to classify an emergency situation (a significant building fire) as an alert. A base civil penalty was warranted for this violation because: (1) this was not the first escalated action in 2 years, (2) credit was not warranted for identification, and (3) credit was warranted for corrective action.

Washington Hospital Center, Washington DC Supplement IV

(EA 98-555)

A Notice of Violation and Proposed Imposition of Civil Penalty in the amount of \$5,500 was issued on March 31, 1999. This action was based on Severity Level III violation involving the loss of control of a nuclear pacemaker, which contained 2.8 curies (Ci) of plutonium-238 (Pu-238). Although full mitigation of the civil penalty would normally be warranted (because credit was warranted for identification and corrective action) the NRC exercised discretion in accordance with Section VII.A.1 and issued twice the base civil penalty. Discretion was warranted because: (1) this case involves the loss of radioactive material, which was intended to be shipped to an entity without verifying that the entity possessed an NRC license for receipt of such material; (2) your performance in this case was poor; and (3) your prior enforcement history has been particularly poor.

APPENDIX C: SUMMARY OF ORDERS

IMPOSITION OF CIVIL PENALTY ORDERS

Deleo, Alfonso Jr., Ardmore, PA

(EA 99-057)

An Order Imposing Civil Penalty in the amount of \$5,500 was issued on August 23, 1999. On June 2, 1999, a Notice of Violation and Proposed Imposition of Civil Penalty in the amount of \$5,500. The action was based on willful, unauthorized possession of nuclear gauges.

Terracon Companies, Tulsa, OK

(EA 98-124)

An Order Imposing Civil Penalty in the amount of \$2,750 was issued on October 19, 1998. On May 5, 1999, a Notice of Violation and Proposed Imposition of Civil Penalty in the amount of \$2,750. The Notice described a failure to maintain constant surveillance of an NRC-licensed nuclear moisture/density gauge, resulting in the gauge's theft from a Terracon vehicle on January 23, 1998. The licensee responded and admitted that the Terracon technician failed to secure a padlock on a gauge container, resulting in the theft of the gauge from the vehicle in which the gauge was being transported. Terracon stated that the actions of the technician constituted "careless disregard of security protocols by a properly trained individual who knowingly violated Terracon policies and NRC regulations," that Terracon had done all that was required by its license, and that the NRC's enforcement action should have been focused on the technician, not Terracon. Terracon also challenged the rationale for the proposed penalty as contradictory, in that the NRC staff gave Terracon credit for its corrective actions but cited the need to prevent similar events from occurring. After consideration of Terracon's responses, the NRC concluded that Terracon was responsible for the violation committed by its technician and that the civil penalty was assessed in accordance with the Enforcement Policy.

Testing Engineers & Consultants, Troy, MI

(EA 99-097 & EA 99-169)

An Order Imposing Civil Penalties in the amount of \$5,500 was issued on September 24, 1999. On July 8, 1999, a Notice of Violation and Proposed Imposition of Civil Penalties in the amount of \$5,500 was issued. The action was based on two willful Severity Level III violations involving the failure to secure and control licensed material and the failure to provide the NRC with complete and accurate information regarding the licensed material (moisture density gauge). The licensee responded and admitted to the violations addressed in the Notice but requested mitigation or remission of the civil penalties. After consideration of the responses, the NRC that neither mitigation nor remission of the civil penalties was warranted.

Thermal Science, Inc., St. Louis, MO

(EA 95-009)

An Order Imposing Civil Penalty in the amount of \$900,000 was issued on May 3, 1999. On October 1, 1996, a Notice of Violation and Proposed Imposition of Civil Penalty in the amount of \$900,000 was issued for nine violations of inaccurate or incomplete information concerning the quality and testing of Thermo-lag material used by licensees to meet Commission requirements. The licensee responded and denied all the violations and provided two legal objections to the Notice. Specifically, Thermal Science, Inc (TSI) stated: (1) NRC lacks authority to impose a civil penalty on a non-licensee like TSI; and (2) NRC's administrative proceeding is criminal rather than civil, and thus violates the Double Jeopardy Clause of the United States Constitution. After consideration of TSI's response, the NRC concluded that the civil penalties were

Appendix C

assessed within the NRC's statutory authority, that imposition of the civil penalties did not violate the Double Jeopardy Clause of the United States Constitution, and that the violations occurred as stated in the Notice.

CONFIRMATORY, MODIFICATION, SUSPENSION, AND CEASE & DESIST ORDERS

NDT Services, Inc., Caguas, Puerto Rico

(EA 99-014)

An Order Modifying License was issued on January 15, 1999. The action was based on the failure to maintain adequate security of licensed material. The Order required that (1) within seven days of receipt of the Order that the licensee temporarily transfer its licensed material; and (2) within thirty days of receipt of the Order the licensee permanently transfer its licensed material to an authorized recipient.

Special Testing Laboratories, Inc., Bethel, Connecticut

(EA 98-521)

An Order Suspending License (Order) was issued on December 23, 1998. The action was issued because of deliberate violations of NRC requirements including the failure to train users and failure to provide TLDs.

APPENDIX D: SUMMARY OF DEMANDS FOR INFORMATION

Envirocare of Utah, Inc., Salt Lake City, UT

(EA 99-180)

A Demand for Information was issued on July 12, 1999. The Demand sought information to determine whether the NRC should modify, suspend, or revoke, or take other appropriate action, regarding the Envirocare license, or take action to prohibit the company's owner from involvement in licensed activities. The bases for the Demand was the NRC's concern regarding the owner's participation in the payment of money and other value to an individual who held official responsibilities as a State of Utah official over matters subject to an Agreement State Program, a program integrally related to the Federal regulatory process administered by the NRC and whether future involvement in NRC-licensed activities would undermine the NRC's reasonable assurance of adequate protection of public health, safety, and interest.

PAGE INTENTIONALLY LEFT BLANK

APPENDIX E: SUMMARY OF CASES INVOLVING EXERCISE OF DISCRETION

Section VII.A - Escalation of Enforcement Sanctions

Anvil Corporation, Bellingham, WA

(EA 99-083)

A Notice of Violation and Proposed Imposition of Civil Penalty in the amount of \$8,800 was issued on June 28, 1999. This action was based on a Severity Level II problem that involved multiple failures to maintain occupational radiation doses, supervise radiographic operations, perform surveys, and wear an operating alarm ratemeter. Although full mitigation would normally be considered appropriate in this case (because credit was warranted for identification and corrective action), the NRC exercised discretion and proposed twice the base civil penalty in accordance with Section VII.A.1. Discretion was warranted because of the significance which NRC assigns to radiation doses in excess of NRC limits which were preventable by basic radiation safety practices.

Baxter Healthcare Corporation, Albonito, PR

(EA 97-518)

A Notice of Violation and Proposed Imposition of Civil Penalties in the amount of \$10,500 was issued on October 9, 1998, for two Severity Level III violations. The first violation was based on willful, unauthorized bypassing of a safety system interlock on an irradiator. Twice the base civil penalty (\$5,000) was proposed in this case because: (1) the violation was considered willful, (2) credit was not warranted for identification, and (3) credit was not warranted for corrective action. The second violation was based on three additional examples where the licensee conducted subsequent, unauthorized repairs to equipment affecting the irradiator control console's "on-off" mechanism. Although a base civil penalty would normally be considered appropriate in this case (because the violation was considered willful, credit was not warranted for identification, and credit was warranted for corrective action), the NRC exercised discretion and proposed twice the base civil penalty in accordance with Section VII.A.1 (\$5,500). Discretion was warranted due to the verbal and written notice the NRC gave to the licensee regarding the specific requirements of its license.

Deleo, Alfonso Jr., Ardmore, PA

(EA 99-217)

A Notice of Violation and proposed imposition of Civil Penalty in the amount of \$15,000 was issued on August 23, 1999, for a Severity Level III violation. This action was based on the continuing willful, unauthorized possession of nuclear gauges (See EA 99-057). The NRC proposed additional civil penalties in the amount of \$15,000 (\$500 a day for the period from July 12 through August 11, 1999).

Indiana Michigan Power Company, Donald C. Cook

(EA 98-150)

A Notice of Violation and Proposed Imposition of Civil Penalties in the amount of \$500,000 was issued on October 13, 1998, for a Severity Level II problem consisting of 37 violations. The violations stemmed from the breakdown in the control of activities that led to the material degradation of multiple systems, including the ice condensers, at the Donald C. Cook units. In accordance with Section VII.A.1 of the Enforcement Policy, discretion was exercised and a \$500,000 civil penalty was issued to reflect the consideration of the particularly poor licensee performance, the duration of the problems, the impact on ECCS and containment, and the NRC's concerns regarding the violations.

International Radiography & Inspection

(EA 98-565 & EA 99-090)

A Notice of Violation and Proposed Imposition of Civil Penalties in the amount of \$17,600 was issued on May 4, 1999, for two Severity Level II problems. The action was based on multiple willful violations including, failing to limit an occupational exposure to NRC limits, failing to have a radiation survey instrument and to conduct radiation surveys at a job site where radiography was being conducted, failing to utilize personnel radiation monitoring equipment, failing to stop radiography and contact the radiation safety officer when the incident occurred, and failing to complete and maintain required records. Although the civil penalties would normally have been fully mitigated (because the licensee identified and corrected the violations), the NRC exercised discretion in accordance with Section VII.A.1 and issued twice the base civil penalties (\$8,800) for each Severity Level II problem because of the willfulness and total disregard for safety.

Northeast Nuclear Energy Company (NNECo), Millstone

(EA 97-461)

A Notice of Violation and Proposed Imposition of Civil Penalty in the amount of \$88,000 was issued on March 9, 1999. This action was based a Severity Level II violation involving the termination of two contractor employees involved in the Motor Operated Valve (MOV) department as retaliation for engaging in protected activities. An OI investigation confirmed those findings, noting that the terminations of the two contractor employees constituted discrimination. The termination of the employment of the two contractor employees occurred in August 1997, after the two individuals had raised concerns about the MOV program manual and the process by which the manual was being reviewed. The terminations were recommended by the then MOV Supervisor, and were supported by the then MOV Manager, both of whom were also contractor employees. Further, the recommendation was neither questioned nor objected to by the Recovery Officer involved with management oversight of the MOV program activities, after the MOV Manager briefed him on the recommendation, nor was it questioned by other Departments within NNECo, including the Contracts or Legal Departments during their reviews. Although full mitigation was considered because credit was warranted for identification and corrective action, the NRC exercised discretion in accordance with Section VII.A.1 of the Enforcement Policy and proposed a base civil penalty. Discretion was warranted in this case, particularly given: (1) the failures by the responsible Recovery Officer and the Contracts and Legal Departments to question the basis for the proposed terminations, despite the opportunities to do so; (2) the failures by senior management in not identifying the management problems in the MOV Department in sufficient time to prevent the terminations, and in being slow in recognizing and responding to the indications of retaliation, as noted in the Little Harbor report; (3) the failure by management to provide training to its contractor supervisors relating to the NRC's employee protection regulation, notwithstanding the Commission's Order dated October 24, 1996, concerning the need to address actions involving a lack of a safety conscious work environment, and to ensure that employees can raise safety concerns without fear of retaliation; and (4) the past history of discrimination violations involving the Millstone station, as evidenced by the three discrimination civil penalties issued between 1993 and 1996.

Washington Hospital Center, Washington DC

(EA 98-555)

A Notice of Violation and Proposed Imposition of Civil Penalty in the amount of \$5,500 was issued on March 31, 1999. This action was based on Severity Level III violation involving the loss of control of a nuclear pacemaker, which contained 2.8 curies (Ci) of plutonium-238 (Pu-238). Although full mitigation of the civil penalty would normally be warranted (because credit was warranted for identification and corrective action) the NRC exercised discretion in accordance with Section VII.A.1 and issued twice the base civil penalty. Discretion was warranted because: (1) this case involves the loss of radioactive material, which was intended to be shipped to an entity without verifying that the entity possessed an NRC license for

receipt of such material; (2) your performance in this case was poor; and (3) your prior enforcement history has been particularly poor.

Section VII.B.2 - Violations Identified During Extended Shutdowns or Work Stoppages

Indiana and Michigan Power, D.C. Cook

(EA 98-509)

On November 9, 1998, an Exercise of Enforcement Discretion letter was issued stating that the NRC intended to exercise enforcement discretion pursuant to Section VII.B.2 of the Enforcement Policy and not issue a Notice of Violation or propose a civil penalty for a Severity Level III violation involving a failure to correctly translate the design-basis of safety-related MOVs into specifications which resulted in 12 MOVs not meeting their continuous structural limit. The NRC concluded that enforcement discretion was appropriate because (1) significant NRC enforcement action (EAs 98-150, 151, 152 & 186 proposed a \$500,000 civil penalty on October 13, 1998) was taken against I&M for several programmatic breakdowns -- including design control issues; (2) the NRC has implemented NRC Manual Chapter 0350 (MC-0350), "Guidelines for Restart Approval," at D. C. Cook to enhance oversight of corrective actions and therefore additional enforcement action is not considered necessary to achieve remedial action for the violation due to I&M's commitment (MC-0350 restart check list item 16) to address MOV issues prior to plant restart; (3) the violation is related to a problem which was present prior to the events leading to the shutdown; (4) the violation is not classified at a Severity Level I; (5) the violation was not willful; and (6) through the MC-0350 process, NRC approval of corrective actions, for those items defined to be within the scope of the process, is required prior to plant restart.

Northeast Nuclear Energy Company (NNECO), Millstone Unit 2

(EA 98-468)

A Notice of Violation for a Severity Level III violation was issued on February 18, 1999. The action was based on a violation that involved a change to the facility made in 1995, with respect to the Auxiliary Feedwater (AFW) system, without first performing a safety evaluation to ensure that the change did not involve an unreviewed safety question. Although a civil penalty is normally considered for a Severity Level III violation, the NRC exercised discretion in accordance with Section VII.B.2 of the Enforcement Policy and refrained from proposing a civil penalty in this case. The decision to exercise discretion was made because: (1) the violation occurred before the extended shutdown of the Millstone units and was considered an additional example of the underlying performance problems that were the basis for the \$2,100,000 civil penalty issued to NNECO on December 12, 1997; (2) the violation was not willful; and (3) the decision to restart Millstone Unit 2 required NRC's concurrence. Although the violation was identified by the NRC, the NRC concluded that a civil penalty in this case was not necessary to achieve remedial action.

Section VII.B.3 - Violations Involving Old Design Issues

Duke Energy Corporation, Catawba

(EA 99-019)

On February 25, 1999, an Exercise of Enforcement Discretion letter was issued stating that the NRC intended to exercise enforcement discretion pursuant to Section VII.B.3 of the Enforcement Policy and not issue a Notice of Violation or propose a civil penalty for a Severity Level III violation involving a design deficiency involving the auxiliary feedwater (CA) pump suction from the condensate storage tank (CACST) and the upper surge tank (UST) that could potentially cause the failure of all three pumps for either unit during a design basis event. Discretion was warranted because: (1) the licensee identified the issue during a self-initiated design review, (2) the licensee implemented timely and effective corrective action and delineated appropriate long-term corrective actions to review and identify any similar design deficiencies, (3) the design deficiency was not likely to have been identified through routine surveillances or quality assurance activities, (4) the low risk significance associated with this design deficiency, and (5) the initial design error was not reflective of the licensee's current performance.

Duke Energy Corporation, Catawba

(EA 99-019)

On July 1, 1999, an Exercise of Enforcement Discretion letter was issued stating that the NRC intended to exercise enforcement discretion pursuant to Section VII.B.3 of the Enforcement Policy and not issue a Notice of Violation or propose a civil penalty for a Severity Level III violation involving a more limiting single failure than previously analyzed, affecting the steam generator tube rupture analysis. Discretion was warranted because: (1) the licensee identified the issues as a result of a voluntary effort, (2) the licensee implemented timely and effective corrective actions, (3) the deficiency was not likely to have been identified through routine surveillances or quality assurance activities, (4) there had not been prior notice such that the licensee should have reasonably identified the violation earlier, and (5) this deficiency was not reflective of the licensee's current performance in this area.

Florida Power & Light Company, St. Lucie

(EA 98-494)

On November 6, 1998, the NRC issued an Exercise of Enforcement Discretion letter stating that it was refraining from issuing a civil penalty or a Notice of Violation for a Severity Level III violation involving inoperable power operated relief valves (PORVs). From approximately 1993 until identification of the issue on August 7, 1998, both Unit 2 PORV block valves were inoperable and the required action was not taken. Discretion was warranted because of: (1) the licensee's prompt identification of the issue after a review of vendor information and an NRC Information Notice, (2) the licensee's prompt corrective actions, (3) the fact that the issue was considered an old design issue which was not likely to be identified through routine licensee efforts, (4) the low risk associated with the postulated failure of the PORV block valves to close, and (5) the issue was not the result of inadequate licensee performance and did not reflect current performance.

Northern States Power Company, Prairie Island

(EA 99-137)

On June 30, 1999, an Exercise of Enforcement Discretion letter was issued stating that the NRC intended to exercise enforcement discretion pursuant to Section VII.B.3 of the Enforcement Policy and not issue a Notice of Violation or propose a civil penalty for a Severity Level III violation involving an undocumented modification to several auxiliary building airlock doors between 1977 and 1982 without consideration of the affects on the design basis of the doors. This modification would have prevented the doors from opening to relieve the pressure assumed in the high-energy line break (HELB) analysis. Discretion was warranted

because: (1) the violation was identified as a result of a voluntary initiative to revise the HELB analysis; (2) the licensee implemented prompt and effective compensatory actions; (3) the violation would not likely have been identified by routine efforts such as through normal surveillance and quality assurance activities; (4) the licensee's ongoing design bases reconstitution efforts as well as improved work order and modification processes should prevent similar occurrences; and (5) the violation was not reasonably linked to present day performance.

PECO Nuclear, Peach Bottom

(EA 98-503)

On November 23, 1998, an Exercise of Enforcement Discretion letter was issued stating that the NRC intended to exercise enforcement discretion pursuant to Section VII.B.3 of the Enforcement Policy and not issue a Notice of Violation or propose a civil penalty for a Severity Level III violation involving the potential for bypass of the suppression pool. Discretion was warranted because: (1) the violation was identified by the licensee's good questioning attitude during voluntary initiatives; (2) corrective actions were comprehensive and timely; (3) the conditions were subtle in nature and not likely to be disclosed through routine surveillance or quality assurance activities; (4) the violation was not reasonably linked to current performance.

PECO Nuclear, Peach Bottom

(EA 99-073)

On May 6, 1999, an Exercise of Enforcement Discretion letter was issued stating that the NRC intended to exercise enforcement discretion pursuant to Section VII.B.3 of the Enforcement Policy and not issue a Notice of Violation or propose a civil penalty for a Severity Level III violation involving the Unit 2 rod block monitoring system being inoperable for 29 of the 185 control rods. Discretion was warranted because: (1) the violation was identified by the licensee's staff who exhibited a good questioning attitude during this voluntary initiative; (2) corrective actions were comprehensive and timely; (3) the conditions that led to the violation were subtle in nature and not likely to be disclosed through routine surveillance or quality assurance activities; and (4) the violation was caused by a wiring error (during initial construction) which was not reasonably linked to current performance.

Pennsylvania Power & Light, Susquehanna

(EA 99-128)

On June 4, 1999, an Exercise of Enforcement Discretion letter was issued stating that the NRC intended to exercise enforcement discretion pursuant to Section VII.B.3 of the Enforcement Policy and not issue a Notice of Violation or propose a civil penalty for a Severity Level III violation involving improper material use in low pressure coolant injection valve stems. Discretion was warranted because: (1) the violation was identified by the licensee's staff who exhibited a good questioning attitude in responding to abnormal plant equipment indications; (2) corrective actions were generally comprehensive and timely; and (3) the initial design error of specifying the improper stem material occurred more than 10 years ago which was not reasonably linked to current performance.

Section VII.B.4 - Violations Identified Due to Previous Enforcement Action

Baltimore Gas and Electric Company, Calvert Cliffs

(EA 98-570)

On December 12, 1998, an Exercise of Enforcement Discretion letter was issued stating that the NRC intended to exercise enforcement discretion pursuant to Section VII.B.4 of the Enforcement Policy and not issue a Notice of Violation or propose a civil penalty for several violations that could be considered for

Appendix E

escalated enforcement. These violations included: (1) safe shutdown Appendix R emergency lighting was inadequate in the Unit 1 main steam isolation valve (MSIV) room and in the area of the Unit 2 emergency shutdown panel; (2) portable air bottles used to operate the auxiliary spray valve was stored in a room where their availability would be in question in the event a fire were to occur in that room; (3) Appendix R isolation hand switches were single fused; (4) a hot short could occur in MOV control cables that could bypass MOV limit switches, cause spurious operation, and potentially damage the valve; and (5) identification of a condition in which RCS/LPSI suction valves could open based on a postulated fire. Discretion was warranted because: (1) the violations were identified by the licensee as part of the corrective action for previous Appendix R related issues; (2) they had the same root cause as the previous issues; (3) they did not substantially change the safety significance or the character of the regulatory concern arising out of those findings; and (4) corrective actions, both taken and planned, were comprehensive and reasonable.

Section VII.B.5 - Violations Involving Discrimination

There were no cases subject to this type of discretion during this period.

Section VII.B.6 - Violations Involving Special Circumstances

Baltimore Gas & Electric, Calvert Cliffs

(EA 99-144)

On June 16, 1999, an Exercise of Enforcement Discretion letter was issued stating that the NRC intended to exercise enforcement discretion pursuant to Section VII.B.6 of the Enforcement Policy and not issue a Notice of Violation or propose a civil penalty for a Severity Level III violation involving an emergency diesel generator (EDG) being inoperable for a period of time in excess of the outage time allowed in the technical specifications. The inoperability of the EDG was the result of foreign material allowed introduced during a modification to the governor control system. Discretion was warranted because: (1) the NRC found that the licensee's foreign material exclusion measures were not unreasonable in light of the information available at the time, and (2) the corrective actions for the event were commensurate with the safety significance of the EDG.

Code Services, Inc., Madison, AL

(EA 99-074)

A Notice of Violation was issued on December May 7, 1999. This action was based on a Severity Level III violation involving the failure to use an alarm ratemeter during the radiographic operations. Although a civil penalty would normally have been proposed (because the licensee had been subject to escalated enforcement within the past 2 years, credit was not warranted for identification, and credit was warranted for corrective action) the NRC exercised discretion in accordance with Section VII.B.6 and refrained from issuing a civil penalty. Discretion was warranted because: (1) the new management/ownership of the company had taken steps to improve staff compliance with safety requirements; (2) significant disciplinary action was taken demonstrating to the employees that this violation would not be tolerated; (3) initial corrective actions taken by the licensee in response to NASA's finding were prompt; and (4) radiographic operations directly observed by the NRC inspector in March 1999 were conducted safely and in accordance with regulatory requirements.

Connecticut Yankee Atomic Power, Haddam Neck***(EA 96-496)***

A Notice of Violation was issued on April 5, 1999. This action was based on a Severity Level III problem involving a November 1996 contamination event caused by poor control of radiological activities which resulted in a plant maintenance supervisor and a contractor refueling manager becoming contaminated while performing activities in the fuel transfer canal. The violations associated created a substantial potential for exposures in excess of regulatory limits. Although a civil penalty would normally be proposed for a Severity Level III problem, the NRC exercised enforcement discretion in accordance with Section VII.B.6 of the Enforcement Policy and did not propose a civil penalty for the violations given that: (1) the violations occurred prior to the licensee's decision, in December 1996, to permanently shutdown the Haddam Neck facility; and (2) the licensee was issued a \$650,000 civil penalty on May 12, 1997, to address the performance problems that existed prior to the decision to permanently shutdown the facility, and which indicated generally poor performance over a period of time.

Consolidate Edison Company, Indian Point 2***(EA 99-152)***

On August 19, 1999, an Exercise of Enforcement Discretion letter was issued stating that the NRC intended to exercise enforcement discretion pursuant to Section VII.B.6 of the Enforcement Policy and not issue a Notice of Violation or propose a civil penalty for a Severity Level III violation involving inadequate design of fifteen motor-operated valve controls circuits, in that fire-induced hot shorts during a postulated control room fire could have impacted the ability of the plant to achieve cold shutdown. The NRC acknowledged that the requirements pertaining to fire-induced circuit failures have been widely misunderstood and have been a point of disagreement within the industry. Accordingly the NRC adopted an interim policy of exercising discretion. Discretion was warranted because: (1) the licensee acknowledged that the violation occurred and (2) the licensee took appropriate and comprehensive corrective actions to address this concern.

DAS Consult, Inc., Dublin, OH***(EA 98-492)***

A Notice of Violation was issued on March 31, 1999. The action was based on a Severity Level II violation involving the deliberate unauthorized transfer of byproduct material. Although a civil penalty would normally be issued in this case, the NRC exercised discretion in accordance with Section VII.B.6 and refrained from issuing a civil penalty. Discretion was appropriate because the licensee suspended operation, divested itself of byproduct material, and requested termination of its license

Envirocare of Utah, Inc.***(EA 98-082)***

On October 19, 1998, an Exercise of Enforcement Discretion letter was issued stating that the NRC intended to exercise enforcement discretion pursuant to Section VII.B.6 of the Enforcement Policy and not issue a Notice of Violation or propose a civil penalty for a Severity Level III violation for possession of significantly more than 350 grams of special nuclear material (SNM). Absent an NRC exemption, quantities of SNM in this amount may be possessed only under an NRC license. The nature of the SNM wastes received for disposal at Envirocare's facility did not present a potential for criticality. However, the violation was determined to represent careless disregard because an Envirocare official had been advised by an NRC official that Envirocare must consider undisposed mobile waste containing SNM in its possession limit. The State of Utah also took enforcement action for exceeding the possession limit, because it is a violation of the State license as well. According to the terms of a Stipulation and Consent Order entered into with the State of Utah, Envirocare agreed to pay an \$80,000 civil penalty, as well as an additional \$20,000 penalty if SNM possession limits are exceeded within one year of the agreement. Because a significant civil penalty was

Appendix E

assessed for the violation by the State, enforcement discretion was considered appropriate and consistent with the Enforcement Policy, Section VI.

Florida Power and Light Company

(EA 98-513)

On March 31, 1999, the NRC notified the licensee that the NRC intended to exercise enforcement discretion pursuant to Section VII.B.6 of the Enforcement Policy and not issue a Notice of Violation or propose a civil penalty for a Severity Level III violation identified by the NRC during a Fire Protection Functional Inspection at the St. Lucie facility. Specifically, the licensee failed to analyze for the potential for more than one fire induced circuit failure that could cause maloperation of designated safe shutdown equipment in all aspects of its safe shutdown analysis. The analysis of multiple fire induced circuit failures has been the subject of continuing discussions with the Nuclear Energy Institute and the NRC. The Office of Nuclear Reactor Regulation intends to issue a generic communication to address the apparent misunderstanding of the requirements by licensees. Discretion was appropriate in this case given that the totality of the inspection findings, and the actions the licensee took in areas directly related to this concern prior to the inspection, make it evident that the licensee's failure to identify this noncompliance stemmed from its misinterpretation of the requirements and not unresponsiveness to NRC concerns or positions. Additionally, Florida Power & Light took prompt, appropriate actions in this case despite its disagreement that the issue constitutes a violation. A Notice of Violation was issued at the same time for a Severity Level III violation involving a lack of fire protection procedural guidance intended to implement the alternative shutdown capability in the vent of a main control room evacuation (see Appendix A).

Maine Yankee Atomic Power Company, Maine Yankee Atomic Power Station ***(EAs 96-299; 96-320; 96-397; 97-034; 97-147; 97-375; 97-559)***

A Notice of Violation for a Severity Level II problem and four Severity Level III problems was issued on October 8, 1998. The Severity Level III problems were related to four broad categories, namely, the failure to: (1) adequately test equipment; (2) environmentally qualify equipment; (3) perform adequate safety reviews; and (4) either identify deficiencies, or take appropriate corrective actions in a timely manner to address known deficiencies, including design related issues. Some of the violations led to safety equipment being inoperable or degraded for extended periods contrary to technical specifications. The Severity Level II violation was based on the licensee operating the facility without having demonstrated that its ECCS systems were capable of mitigating the most severe postulated loss-of-coolant accident. Civil penalties were not proposed because: (1) Maine Yankee essentially replaced the entire management infrastructure since the time these problems occurred, and the new management was effective in safely managing shutdown and decommissioning operations; (2) the fact that the Maine Yankee facility had been shutdown since December 5, 1996, was permanently retired on August 6, 1997, and the violations at issue here are not reflective of Maine Yankee's post shutdown and decommissioning performance; and, (3) unlike Haddam Neck in which a substantial civil penalty was imposed after declaring permanent retirement of the facility, Maine Yankee was not in the business of operating other nuclear power facilities.

Northeast Nuclear Energy Company (NNECo), Millstone

(EA 98-325)

A Notice of Violation was issued on April 6, 1999. This action was based on three Severity Level II violations related to discrimination of plant employees. The NRC concluded that discrimination occurred in two OI Cases. OI Case No.1-96-002 involved two supervisors demoted as a result of a 1993 reorganization. A Supervisor in the Performance Engineering group engaged in protected activities with regard to check valve operability issues and his active support of another Millstone employee who had raised safety concerns about spent fuel off-loading practices at Millstone. These protected activities were a

contributing factor in his demotion and was thus, discrimination which is prohibited by 10 CFR 50.7. A Supervisor in the Engineering Mechanics group engaged in protected activities with regard to the safety-related motor-operated valve program, heat exchanger issues, and reactor coolant pump maintenance problems at Millstone. The protected activities were a contributing factor in removal of his responsibilities and in a demotion and thus, was discrimination prohibited by 10 CFR 50.7. With regard to OI Case No. 1-97-007 a Supervisor, Electrical Engineering at Millstone Unit 2 in August 1995, was dismissed after reporting to higher-level management and the Millstone Nuclear Safety Concerns Program that his immediate superior had threatened him and another employee with dismissal if a system modification was not completed before the scheduled conclusion of a Millstone Unit 2 refueling outage. The NRC concluded that the Electrical Engineering Supervisor's protected activity was a contributing factor in his dismissal and that the dismissal was thus, discrimination which is prohibited by 10 CFR 50.7. In recognition of the fact that the Licensee had taken substantial actions to address and correct the general and widespread employee concerns and discrimination problems that existed at the time of the violations, the NRC exercised discretion pursuant to the special circumstances provisions of Section VII.B.6 of the Enforcement Policy and refrained from issuing civil penalties in this case.

Pacific Gas and Electric Company, Diablo Canyon

(EA 98-185)

On November 16, 1998, an Exercise of Enforcement Discretion letter was issued stating that the NRC intended to exercise enforcement discretion pursuant to Section VII.B.6 of the Enforcement Policy and not issue a Notice of Violation or propose a civil penalty for a Severity Level III violation that involved the simultaneous inoperability of the Unit 2 Train A safety injection pump, the Train A residual heat removal pump, and Valve 8923A, the Train A safety injection suction from refueling water storage tank. This condition occurred for 14 hours 30 minutes in November 1989 and rendered both trains of safety injection inoperable for the long-term recirculation cooling mode. This condition also existed during the maintenance of these components and resulted from a then-unrecognized interdependency of cold leg recirculation suction flow paths between the emergency core cooling system trains. The condition was identified through review of historical records several years after occurrence when licensee engineers were evaluating new industry information. Discretion was warranted because of: the age of the issue, its isolated occurrence, the fact that it was not likely to be identified by routine licensee efforts, and the initiative demonstrated by the licensee to identify and promptly correct the potential condition.

Southern California Edison Co., San Onofre

(EA 98-226)

On November 12, 1998, the NRC issued an Exercise of Enforcement Discretion letter stating that it was refraining from issuing a Notice of Violation or a civil penalty for a violation involving the failure of a reversing linestarter (due to grit from initial construction on mechanical surfaces) in the electrical power circuit associated with the Train A motor-operated, containment emergency sump outlet valve which would have prevented the valve from opening. With this valve unable to open on a containment sump circulation actuation signal, and with the Train B recirculation system unavailable due to planned maintenance, San Onofre was operated for a period of approximately 27 hours in January 1998, with no post-accident recirculation capability available, contrary to the requirements of the plant's technical specifications. Given the loss of function of this safety system, this violation would normally have been categorized at Severity Level II in accordance with the Enforcement Policy. However, the risk significance was lessened by the relatively short duration of the loss of safety function (approximately 27 hours) and the recovery potential by plant personnel. In addition, this was the only known failure of a linestarter due to grit in approximately 16 years of operation, indicating that this failure was isolated. Based on these considerations, the staff concluded that this issue was more appropriately classified at Severity Level III. Further, because the failure was considered not preventable by reasonable quality assurance activities and other management controls

Appendix E

the NRC determined that enforcement discretion was warranted as provided for in Section VII.B.6 of the Enforcement Policy.

Temple University Hospital

(EA 98-485)

On February 24, 1999, an Exercise of Enforcement Discretion letter was issued stating that the NRC intended to exercise enforcement discretion pursuant to Section VII.B.6 of the Enforcement Policy and not issue a Notice of Violation or propose a civil penalty for a Severity Level III violation involving the creation of incomplete and inaccurate information on dose dispensing forms. Discretion was exercised because: (1) enforcement action was previously taken against the licensee for a violation caused by deliberate misconduct by the same individual with regard to the record of the weekly wipe test survey for removable contamination; (2) the violation was an additional example of the previously cited violation, involved the same individual, and pertained to activities that took place prior to and during the same period of time as the falsification of the weekly wipe test survey; and (3) corrective actions were considered comprehensive.

Tennessee Valley Authority, Sequoyah 1 & 2

(EA 99-207)

On September 21, 1999, an Exercise of Enforcement Discretion letter was issued stating that the NRC intended to exercise enforcement discretion pursuant to Section VII.B.6 of the Enforcement Policy and not issue a Notice of Violation or propose a civil penalty for a Severity Level III violation involving failure to get prior Commission approval in accordance with 10 CFR 50.59 for procedural changes that resulted in three containment penetrations being left open during the April 1999 refueling outage. Discretion was warranted because: (1) the NRC's review of these issues, as documented in the 1991 inspection report, contributed to the failure to address the complete spectrum of regulatory issues at that time and (2) the licensee was responsive in actively considering options to fully address these issues for any upcoming refueling operations.

United States Enrichment Corporation

(EA 98-239)

On October 9, 1998, an Exercise of Enforcement Discretion letter was issued stating that the NRC intended to exercise enforcement discretion pursuant to Section VII.B.6 of the Enforcement Policy and not issue a Notice of Violation or propose a civil penalty for a Severity Level III problem involving a nonconservative assumption in the Safety Analysis Report (SAR) updated accident analysis. The issue involved a seismic accident analysis which assumed no liquid uranium hexafluoride (UF₆) in the accumulators. This assumption underestimated the potential source term for the seismic accident scenario. USEC operates with liquid UF₆ in the accumulators. Discretion was warranted because of: (1) the difference between current requirements and previous (old) design practices which appeared to allow the seismic design and accident analysis assumptions used by USEC; (2) USEC's prompt compensatory measures and comprehensive design changes to resolve the seismic weakness, as detailed in a Confirmatory Order issued to USEC on April 22, 1998 (EA 98-156); and (3) USEC's corrective actions to improve the rigor and documentation of safety evaluations for as-found conditions.

United States Enrichment Corporation

(EA 98-455)

On November 24, 1998, an Exercise of Enforcement Discretion letter was issued stating that the NRC intended to exercise enforcement discretion pursuant to Section VII.B.6 of the Enforcement Policy and not propose a civil penalty for a violation involving a failure to limit the discharge bellow pressure on a Normetex withdrawal pump below a safety limit described in Paducah's Technical Safety Requirements (TSRs). Supplement VI.A.5 of the Enforcement Policy provides that exceeding a safety limit would

normally be classified as a Severity Level I violation. In this case, however, the NRC exercised enforcement discretion because: (1) USEC's failure to maintain the Normetex pump discharge bellow pressure to within the safety limit had minimal, if any, potential safety consequences; (2) the presence of a process gas leak detection system, a separate safety system, would have mitigated the consequences from all Normetex pump discharge piping failures; and (3) the Normetex pump discharge piping pressure limit does not meet the current criteria of 10CFR76.4 for designation as a safety limit. Enforcement discretion was also exercised pursuant to Section VII.B.6 of the Enforcement Policy to cite the violation at Severity Level IV.

PAGE INTENTIONALLY LEFT BLANK

**APPENDIX F: SUMMARY OF ACTIONS AGAINST
LICENSED INDIVIDUALS**

ORDERS AND DEMANDS FOR INFORMATION (DFIs)

None

NOTICES OF VIOLATION (NOVs)

Steven M. Allison

IA 99-010

A Notice of Violation was issued on March 25, 1999, for a violation of NRC requirements governing Fitness-for-Duty as a licensed operator.

Timothy Hartnett

IA 98-056

A Notice of Violation was issued on November 19, 1998, for leaving the controls of the reactor unattended.

Donald T. Hughes, Jr.

IA 99-028

A Notice of Violation was issued on June 10, 1999, for failure to comply with Fitness-for-Duty requirements.

Emil McCormic

IA 99-008

A Notice of Violation was issued on March 25, 1999, for failure to comply with Fitness-for-Duty requirements.

PAGE INTENTIONALLY LEFT BLANK

APPENDIX G: SUMMARY OF ACTIONS AGAINST NON-LICENSED INDIVIDUALS

ORDERS

A. Abdulshafi

IA 98-058

An Order Prohibiting Involvement in NRC-Licensed Activities was issued March 31, 1999. The action was based on the deliberate transfer of moisture density gauges containing byproduct material to a person not authorized to possess such material. The Order prohibits his involvement in NRC-licensed activities for a period of one year and establishes other requirements as stated in the Order.

Randall Allmon

IA 98-061

A Confirmatory Prohibiting Involvement in NRC-Licensed Activities was issued on January 27, 1999. The action was based on the deliberate submittal of inaccurate information. The Order prohibits his involvement in NRC-licensed activities for a period of five years.

Sheila N. Burns

IA 98-067

An Order Prohibiting Involvement in NRC-Licensed Activities was issued on April 29, 1999. The action was based on deliberately conducting radiography without a radiation survey instrument and deliberately providing her employer with false information about the incident. The Order prohibits involvement in NRC-licensed activities for a period of three years, requires Ms. Burns to inform any employer who holds any NRC of Agreement State license of the restrictions contained in the Order, and requires Ms. Burns to notify the NRC if she elects to return to employment in NRC-licensed activities after the 3-year prohibition expires.

William H. Clark

IA 98-045

An Order Prohibiting Involvement in NRC-Licensed Activities was issued December 21, 1998. The action was based on an investigation which concluded that Mr. Clark deliberately provided false information to two NRC licensees. He provided false information regarding his prior failure of a fitness for duty drug test and his prior denial of unescorted access to a nuclear facility in order to gain unescorted access to the Indian Point-3 and Perry facilities. The Order prohibits Mr. Clark from engaging in NRC-licensed activities for a period of one year and for a period of one year following the prohibition to notify the NRC each time he engages in NRC-licensed activities.

James S. Dawson

IA 99-002

An Order Prohibiting Involvement in NRC-Licensed Activities was issued on April 29, 1999. The action was based on deliberately conducting radiography without a radiation survey instrument and deliberately providing his employer with false information about the incident. The Order prohibits involvement in NRC-licensed activities for a period of three years, requires Mr. Dawson to inform any employer who holds any NRC of Agreement State license of the restrictions contained in the Order, and requires Mr. Dawson to notify the NRC if he elects to return to employment in NRC-licensed activities after the 3-year prohibition expires.

Mohammed El Naggar

IA 98-059

An Order Prohibiting Involvement in NRC-Licensed Activities was issued March 31, 1999. The action was based on the deliberate receipt of moisture density gauges containing byproduct material without authorization to possess such material. The Order prohibits his involvement in NRC-licensed activities for a period of one year and establishes other requirements as stated in the Order.

Gary Isakoff

IA 98-006

An Order Prohibiting Involvement in NRC-Licensed Activities was issued February 24, 1999. The action was based on deliberate falsification of a weekly wipe test survey for removable contamination repeated and willful inaccurate recordation and failure to record information pertaining to the administration of doses on Dose Dispensing Forms (DDFs). The Order prohibits Mr. Isakoff from involvement in licensed activities for one year, and requires that for one year thereafter he shall provide notice to the NRC Office of Enforcement of his acceptance of any offers of employment involving NRC-licensed activities. (This Order was subsequently withdrawn; see Appendix L.)

Peter Kint

IA 99-001

An Order Prohibiting Involvement in NRC-Licensed Activities was issued on March 1, 1999. The action was based on the individual deliberately failing to wear his alarming ratemeter. The Order prohibits his involvement in NRC-licensed activities for a period of one year and establishes other requirements as stated in the Order.

Lee LaRocque

IA 98-065

An Order Prohibiting Involvement in NRC-Licensed Activities (Order) was issued on February 24, 1999. The action was based on deliberate and repeated misconduct in violation of 10 C.F.R. § 30.10, "Deliberate misconduct." Specifically, while employed as a Nuclear Medicine Technologist (NMT) at Windham Community Memorial Hospital, the individual deliberately: (1) altered the dose calibrator reading for an iodine-131 (I-131) capsule, which was to be administered to a patient; (2) administered the capsule containing a dose of I-131 in excess of that authorized by the hospital's NRC license; and (3) created an inaccurate record of that dose, required to be maintained by 10 C.F.R. § 35.53(a) and (c), contrary to 10 C.F.R. § 30.9, "Completeness and accuracy of information." Among other things, the Order prohibits the individual from engaging in NRC-licensed activities for a period of one year from the date of the Order.

Stanislaw Piorek

IA 99-037

A Confirmatory Prohibiting Involvement in NRC-Licensed Activities was issued on August 19, 1999. The action was based on the deliberate failure to stop unauthorized distribution of licensed material (x-ray fluorescence analyzer devices) and failure to submit quarterly reports. The Order (1) prohibits his involvement in NRC-licensed activities for a period of three years and (2) requires that, no less than five days prior to the first time that you engage in NRC-licensed activities during a period of five years following the 3-year prohibition, he provide written notice to the NRC of the name, address, and telephone number of the NRC or Agreement State licensee and the location where the licensed activities will be performed.

Brian K. Rogers***IA 98-062***

A Confirmatory Prohibiting Involvement in NRC-Licensed Activities was issued on January 27, 1999. The action was based on the deliberate submitted inaccurate information. The Order prohibits his involvement in NRC-licensed activities for a period of five years.

Richard A. Speciale***IA 99-091***

An Order Prohibiting Involvement in NRC-Licensed Activities (Order) was issued on July 21, 1999. The action was on deliberate misconduct to secure and control licensed material without proper certification and training and deliberate failure to provide NRC with accurate information regarding the licensed material (portable gauges). The Order prohibits his involvement in NRC-licensed activities for a period of five years and for a period of one year after the five-year period of prohibition has expired, Mr. Speciale shall, within 20 days of his acceptance of each employment offer involving NRC-licensed activities.

Dale Todd***IA 98-066***

An Order Prohibiting Involvement in NRC-Licensed Activities was issued on March 31, 1999. The action was based on the individual deliberately conducting NRC-licensed activities without a specific or general licensed issued by the NRC. Under the terms of the Order, both Mr. Todd and Roof Systems Design, Inc. are (1) prohibited from engaging in NRC licensed activities for a period of one year and (2) required to notify the NRC at least five days prior to the first time that he engages in or exercises control over NRC licensed activities during a period of five years following the one year prohibition.

NOTICES OF VIOLATION (NOVs)***David Branham******IA 99-016***

A Notice of Violation was issued on April 30, 1999, for falsifying the record of the release rate calculation verifications.

John Chmielorz***IA 99-011***

A Notice of Violation was issued on June 17, 1999, for the deliberate failure to allow use of nuclear gauge without proper certification and dosimetry.

Charles W. Davis***IA 99-009***

A Notice of Violation was issued on March 29, 1999, for deliberate violation of the NRC-required fitness for duty (FFD) program.

Eric DeBarba***IA 99-012***

A Notice of Violation was issued on April 6, 1999. The action was based on discrimination against two supervisors for raising safety concerns.

Appendix G

Richard W. Dungan

IA 99-026

A Notice of Violation was issued on July 13, 1999. The action was based on the individual's deliberate actions in allowing an employee to use licensed material (Troxler gauge) without proper training, without being designated by the RSO as an authorized user, without being in the presence of an authorized user, and without proper dosimetry.

Kennth F. Enoch

IA 99-036

A Notice of Violation was issued on July 23, 1999, for the deliberate falsification of a surveillance procedure.

Neil Everson

IA 99-031

A Notice of Violation was issued on July 20, 1999, for deliberate violation of the procedures implementing the NRC-approved security plan for the Zion Station.

Edwin S. Feemster

IA 99-007

A Notice of Violation was issued on June 7, 1999, for failure to maintain an accurate training attendance record.

Joseph M. Foley

IA 98-055

A Notice of Violation was issued on May 12, 1999, for providing inaccurate information to the NRC.

Raymond E. Landrum

IA 99-052

A Notice of Violation was issued on November 3, 1999, for deliberate misconduct involving discrimination against a Senior Reactor Operator (SRO).

Gary Pageau

IA 99-003

A Notice of Violation was issued on August 3, 1999, for deliberate misconduct involving discrimination against an electrician for raising safety concern.

Todd Ripplinger

IA 98-057

A Notice of Violation was issued on February 24, 1999. The action was based on: (1) deliberately allowing a newly-hired technologist to perform routine nuclear medicine activities, knowing that the technologist did not yet have the dosimetry required for those activities; and (2) deliberately instructing two technologists to state, in depositions with an NRC investigator, that the newly-hired technologist did not perform nuclear medicine activities without the required dosimetry, even though you knew that he had performed those activities without the required dosimetry.

Bradley K. Sherwin

IA 99-030

A Notice of Violation was issued on July 8, 1999, for deliberate failure to secure and control licensed material and deliberate failure to provide the NRC with complete and accurate information regarding the licensed material (moisture density gauge).

Charles H. Tewksbury

IA 99-045

A Notice of Violation was issued on September 30, 1999. The action was based on deliberate misconduct involving discrimination against a QV inspector for raising safety concern.

Michael Thomas

IA 98-064

A Notice of Violation was issued on May 12, 1999, for deliberately attempting to conceal the release of the contaminated video equipment.

A. Davey Wells

IA 98-004

A Notice of Violation was issued on January 5, 1999. The action was based on providing an NRC senior resident inspector at the River Bend Station (RBS) with information that the individual knew was incomplete and inaccurate.

DEMANDS FOR INFORMATION (DFIs)

Todd Ripplinger

IA 98-057

A Demand for Information was issued in conjunction with a Notice of Violation on February 24, 1999. The Demand requested a response as to why NRC should not issue an Order to the individual to remove him from future licensed activities because of his deliberate actions as described in the Notice of Violation above.

PAGE INTENTIONALLY LEFT BLANK

APPENDIX H: SUMMARY OF ACTIONS AGAINST NON-LICENSED PERSONS OTHER THAN INDIVIDUALS

IMPOSITION OF CIVIL PENALTY ORDERS

Thermal Science, Inc., St. Louis, MO

(EA 95-009)

An Order Imposing Civil Penalty in the amount of \$900,000 was issued on May 3, 1999. On October 1, 1996, a Notice of Violation and Proposed Imposition of Civil Penalty in the amount of \$900,000 was issued for nine violations of inaccurate or incomplete information concerning the quality and testing of Thermo-lag material used by licensees to meet Commission requirements. The licensee responded and denied all the violations and provided two legal objections to the Notice. Specifically, Thermal Science, Inc (TSI) stated: (1) NRC lacks authority to impose a civil penalty on a non-licensee like TSI; and (2) NRC's administrative proceeding is criminal rather than civil, and thus violates the Double Jeopardy Clause of the United States Constitution. After consideration of TSI's response, the NRC concluded that the civil penalties were assessed within the NRC's statutory authority, that imposition of the civil penalties did not violate the Double Jeopardy Clause of the United States Constitution, and that the violations occurred as stated in the Notice.

ORDERS

March Metalfab, Inc., Hayward, California

(EA 98-529)

A Confirmatory Order Prohibiting Involvement in NRC-Licensed Activities was issued on January 27, 1999. The action was based on the company deliberately providing inaccurate and incomplete information to the NRC. The company was prohibited from any involvement in NRC-licensed activities for five years.

Morrison Knudsen Corporation

(EA 98-081)

A Confirmatory Order was issued on September 24, 1999. The Order confirmed the company's commitment to take certain corrective actions regarding enhancing the work environment and reinforcing the importance of maintaining a safety conscious work environment and of assisting managers and supervisors in responding to employees who raise safety concerns in the workplace.

CIVIL PENALTIES

None

NOTICES OF VIOLATION (NOVs)

Williams Powers Co. Supplement VII

(EA 98-338)

A Notice of Violation was issued on August 3, 1999. This action was based on a Severity Level III violation for discrimination against an employee at the Seabrook nuclear facility for raising safety concerns.

Appendix H

DEMANDS FOR INFORMATION (DFIs)

None

APPENDIX I: SUMMARY OF CASES INVOLVING DISCRIMINATION

*Coriell Institute for Medical Research, Camden, NJ
Supplement VII*

(EA 99-060)

A Notice of Violation and Proposed Imposition of Civil Penalty in the amount of \$4,400 was issued on June 2, 1999, for a Severity Level II violation. The action was based on discrimination against an employee for raising safety concern. Specifically, a laboratory technician raised a safety concern regarding unnecessary exposure to employees from phosphorus-32, in a Coriell laboratory on September 13, 1996. A base civil penalty was proposed in this case because: (1) the violation was considered willful, (2) credit was not warranted for identification, and (3) credit was warranted for corrective action.

Eric DeBarba

(IA 99-012)

A Notice of Violation was issued on April 6, 1999. The action was based on discrimination against two supervisors for raising safety concerns.

*FirstEnergy Nuclear Operating Company, Perry Nuclear Power Plant
Supplement VII*

(EA 99-012)

A Notice of Violation and Proposed Imposition of Civil Penalty in the amount of \$110,000 was issued on May 20, 1999. This action was based on a Severity Level II violation involving an investigation completed by the NRC Office of Investigations (OI) at the Perry Nuclear Power Plant owned by Centerior Energy Corporation (now FirstEnergy Nuclear Operating Company (FENOC)) on December 10, 1998. OI conducted the investigation to determine whether a Radiation Protection Supervisor (RPS) at the Perry facility was discriminated against for providing testimony as a witness in a hearing concerning another employee. Based upon the evidence developed, OI determined that the Perry Radiation Protection Manager (RPM) discriminated against a RPS for engaging in protected activities within the scope of 10 CFR 50.7. The RPS's protected activities pertained to a July 17, 1997, deposition that the RPS was to give in a Department of Labor (DOL) hearing concerning alleged employment discrimination against another individual at the Perry facility. The RPS had previously suggested to Centerior Energy representatives that his testimony would not be favorable to the Centerior Energy Corporation. The discrimination against the RPS consisted of a July 16, 1997, verbal counseling and the placement of a July 17, 1997, memorandum documenting the verbal counseling in the RPS's section personnel file on July 22, 1997. This violation was a very significant concern because it involved employee discrimination by the RPM, a mid-level facility manager, against an employee for testifying in a DOL proceeding. Such testimony is a protected activity in the Commission's employee protection regulations. Furthermore, the sphere of influence of the RPM is broad. Discrimination committed at this level had the potential to create a chilling effect throughout the Radiation Protection Department and could influence individuals in other plant departments. Twice the base civil penalty (\$176,000) was warranted for this violation because: (1) this was not the first escalated action in 2 years, (2) credit was not warranted for identification, and (3) credit was not warranted for corrective action. However a civil penalty in the amount of \$110,000 was proposed because the NRC's statutory authority limits the amount of a civil penalty to \$110,000 per violation per day.

Appendix I***Illinois Power Co., Clinton
Supplement VII******(EA 98-464)***

A Notice of Violation was issued September 30, 1999. The action was based on a Severity Level III violation involving discrimination against a quality verification inspector for bringing safety concerns to the NRC. Although the violation was willful and the facility had been the subject of escalated enforcement action within the last 2 years, the civil penalty was fully mitigated because credit was warranted for identification and corrective action.

Raymond E. Landrum***(IA 99-052)***

A Notice of Violation was issued on November 3, 1999, for deliberate misconduct involving discrimination against a Senior Reactor Operator (SRO).

Morrison Knudsen Corporation***(EA 98-081)***

A Confirmatory Order was issued on September 24, 1999. The Order confirmed the company's commitment to take certain corrective actions regarding enhancing the work environment and reinforcing the importance of maintaining a safety conscious work environment and of assisting managers and supervisors in responding to employees who raise safety concerns in the workplace.

***Northeast Nuclear Energy Company (NNECo), Millstone
Supplement I,******(EA 97-461)***

A Notice of Violation and Proposed Imposition of Civil Penalty in the amount of \$88,000 was issued on March 9, 1999. This action was based a Severity Level II violation involving the termination of two contractor employees involved in the Motor Operated Valve (MOV) department as retaliation for engaging in protected activities. An OI investigation confirmed those findings, noting that the terminations of the two contractor employees constituted discrimination. The termination of the employment of the two contractor employees occurred in August 1997, after the two individuals had raised concerns about the MOV program manual and the process by which the manual was being reviewed. The terminations were recommended by the then MOV Supervisor, and were supported by the then MOV Manager, both of whom were also contractor employees. Further, the recommendation was neither questioned nor objected to by the Recovery Officer involved with management oversight of the MOV program activities, after the MOV Manager briefed him on the recommendation, nor was it questioned by other Departments within NNECo, including the Contracts or Legal Departments during their reviews. Although full mitigation was considered because credit was warranted for identification and corrective action, the NRC exercised discretion in accordance with Section VII.A.1 of the Enforcement Policy and proposed a base civil penalty. Discretion was warranted in this case, particularly given: (1) the failures by the responsible Recovery Officer and the Contracts and Legal Departments to question the basis for the proposed terminations, despite the opportunities to do so; (2) the failures by senior management in not identifying the management problems in the MOV Department in sufficient time to prevent the terminations, and in being slow in recognizing and responding to the indications of retaliation, as noted in the Little Harbor report; (3) the failure by management to provide training to its contractor supervisors relating to the NRC's employee protection regulation, notwithstanding the Commission's Order dated October 24, 1996, concerning the need to address actions involving a lack of a safety conscious work environment, and to ensure that employees can raise safety concerns without fear of retaliation; and (4) the past history of discrimination violations involving the Millstone station, as evidenced by the three discrimination civil penalties issued between 1993 and 1996.

***Northeast Nuclear Energy Company (NNECo), Millstone
Supplement VI******(EA 98-325)***

A Notice of Violation was issued on April 6, 1999. This action was based on three Severity Level II violations related to discrimination of plant employees. The NRC concluded that discrimination occurred in two OI Cases. OI Case No.1-96-002 involved two supervisors demoted as a result of a 1993 reorganization. A Supervisor in the Performance Engineering group engaged in protected activities with regard to check valve operability issues and his active support of another Millstone employee who had raised safety concerns about spent fuel off-loading practices at Millstone. These protected activities were a contributing factor in his demotion and was thus, discrimination which is prohibited by 10 CFR 50.7. A Supervisor in the Engineering Mechanics group engaged in protected activities with regard to the safety-related motor-operated valve program, heat exchanger issues, and reactor coolant pump maintenance problems at Millstone. The protected activities were a contributing factor in removal of his responsibilities and in a demotion and thus, was discrimination prohibited by 10 CFR 50.7. With regard to OI Case No. 1-97-007 a Supervisor, Electrical Engineering at Millstone Unit 2 in August 1995, was dismissed after reporting to higher-level management and the Millstone Nuclear Safety Concerns Program that his immediate superior had threatened him and another employee with dismissal if a system modification was not completed before the scheduled conclusion of a Millstone Unit 2 refueling outage. The NRC concluded that the Electrical Engineering Supervisor's protected activity was a contributing factor in his dismissal and that the dismissal was thus, discrimination which is prohibited by 10 CFR 50.7. In recognition of the fact that the Licensee had taken substantial actions to address and correct the general and widespread employee concerns and discrimination problems that existed at the time of the violations, the NRC exercised discretion pursuant to the special circumstances provisions of Section VII.B.6 of the Enforcement Policy and refrained from issuing civil penalties in this case.

***North Atlantic Energy Service Corporation (NAESCO), Seabrook Station
Supplement VII******(EA 98-165)***

A Notice of Violation and Proposed Imposition of Civil Penalty in the amount of \$55,000 was issued on August 3, 1999. This action was based on Severity Level III violation of NRC requirements involving discrimination by Williams Power Corporation (WPC), a contractor of NAESCO, against an electrician for raising safety issues. A base civil penalty was proposed for this violation because: (1) this was a willful violation, (2) credit was not warranted for identification, and (3) credit was warranted for corrective action.

Gary Pageau***(IA 99-003)***

A Notice of Violation was issued on August 3, 1999, for deliberate misconduct involving discrimination against an electrician for raising safety concern.

Charles H. Tewksbury***(IA 99-045)***

A Notice of Violation was issued on September 30, 1999. The action was based on deliberate misconduct involving discrimination against a QV inspector for raising safety concern.

Appendix I

Williams Powers Co.
Supplement VII

(EA 98-338)

A Notice of Violation was issued on August 3, 1999. This action was based on a Severity Level III violation for discrimination against an employee at the Seabrook nuclear facility for raising safety concerns.

APPENDIX J: SUMMARY OF HEARING ACTIVITY

Ben-Haim, Aharon, Ph.D.

(IAs 97-065, 97-068)

A request for a hearing and a request to stay the immediate effectiveness of an Order were received on August 19, 1997. The Order prohibits the individual from involvement in NRC-licensed activities. On September 18, 1997, the Licensing Board ruled that it would not rescind the immediate effectiveness of the Order. The hearing on the Order was held May 27-29, 1998. On February 8, 1999, the Atomic Safety and Licensing Board issued its Initial Decision and sustained the Order but modified the prohibition period from five years to three years. On February 24, 1999, the NRC staff petitioned the Commission for review of the Board's decision. Dr. Ben-Haim petitioned the Commission for review of the Board's decision on March 14, 1999. On April 26, 1999, the Commission denied both petitions.

Gary Isakoff

IA 98-006

On March 16, 1999, Mr. Isakoff requested a hearing in response to an Order Prohibiting Involvement in NRC-Licensed Activities that was issued to him by the NRC in a letter dated February 24, 1999. The action was based on deliberate falsification of a weekly wipe test survey for removable contamination repeated and willful inaccurate recordation and failure to record information pertaining to the administration of doses on Dose Dispensing Forms (DDFs). On August 2, 1999, Mr. Isakoff and the NRC filed a joint motion asking the Atomic Safety and Licensing Board to approve a settlement agreement. On August 11, 1999, the Atomic Safety and Licensing Board approved the settlement agreement and dismissed the proceeding. The agreement provides that the Order against Mr. Isakoff be withdrawn (see further discussion in Appendix L).

PAGE INTENTIONALLY LEFT BLANK

APPENDIX K: SUMMARY OF 10 CFR 2.206 ACTIVITY***Director's Decision-99-10***

A petition was received on March 31, 1999, on Seabrook Nuclear Power Station requesting: (1) that the NRC take enforcement action against individuals alleged to have unlawfully discriminated against a contract electrician in violation of 10 CFR 50.7; (2) that the NRC take enforcement action against individuals alleged to have created a false record in violation of 10 CFR 50.9; and (3) that the Petitioner be granted permission to attend an upcoming predecisional enforcement conference between the NRC and the licensee on these matters. This issue was addressed in Director's Decision-99-10, dated August 3, 1999, in which the Director, Office of Enforcement, determined that the petition should be denied for the reasons stated in the decision. While the NRC staff concluded that the foreman had engaged in wrongdoing, the Director, Office of Enforcement denied the Petitioner's request to ban the foreman from participating in licensed activities for a period of at least five years because the requested enforcement action was not appropriate based on the circumstances of the case. The Director's Decision and the Notices of Violation issued to the foreman, Williams Power Corporation, and NAESCO for the foreman's wrongdoing are on the NRC's web page at <http://www.nrc.gov/NRC/PUBLIC/2206/index.html> and http://www.nrc.gov/OE/rpr/oe_5.htm respectively.

PAGE INTENTIONALLY LEFT BLANK

APPENDIX L: SUMMARY OF WITHDRAWN ENFORCEMENT ACTIONS

Gary Isakoff

IA 98-006

On August 11, 1999, the NRC withdrew an Order Prohibiting Involvement in NRC-Licensed Activities issued by the NRC in a letter dated February 24, 1999. The case was originally proposed for deliberate falsification of a weekly wipe test survey for removable contamination repeated and willful inaccurate recordation and failure to record information pertaining to the administration of doses on Dose Dispensing Forms (DDFs). The NRC withdrew the Order under the settlement agreement that Mr. Isakoff not engage in NRC-licensed activities for one year, and that for an additional three-year period, he provide notice to the NRC Office of Enforcement of his acceptance of any offers of employment involving NRC-licensed activities.