

TOPIC: 291004
KNOWLEDGE: K1.01 [3.2/3.2]
QID: B218 (P221)

A centrifugal pump is initially operating at rated flow rate in an open system. Which one of the following moderate changes will cause the pump to operate in closer proximity to cavitation?

- A. Increase pump inlet temperature.
- B. Decrease pump speed.
- C. Increase pump suction pressure.
- D. Decrease pump recirculation flow rate.

ANSWER: A.

TOPIC: 291004
KNOWLEDGE: K1.01 [3.2/3.2]
QID: B320

Which one of the following changes in nuclear power plant status will bring the reactor recirculation system closer to the condition in which the recirculation pump will cavitate?

- A. During a plant shutdown, recirculation pump suction temperature decreases while reactor pressure remains constant.
- B. Recirculation pump speed increases.
- C. Reactor water level increases.
- D. During reactor power operations, extraction steam to one of the high pressure feedwater heaters isolates.

ANSWER: B.

TOPIC: 291004
KNOWLEDGE: K1.01 [3.2/3.2]
QID: B1018 (P1520)

If a centrifugal pump is started with the discharge valve fully open, versus throttled, the possibility of pump runout will _____ and the possibility of pump cavitation will _____.

- A. increase; decrease
- B. increase; increase
- C. decrease; decrease
- D. decrease; increase

ANSWER: B.

TOPIC: 291004
KNOWLEDGE: K1.01 [3.2/3.2]
QID: B1218 (P1220)

Which one of the following describes pump cavitation?

- A. Vapor bubbles are formed when the enthalpy difference between pump discharge and pump suction exceeds the latent heat of vaporization.
- B. Vapor bubbles are formed in the eye of the pump impeller and collapse as they enter higher pressure regions of the pump.
- C. Vapor bubbles are produced when the localized pressure exceeds the vapor pressure at the existing temperature.
- D. Vapor bubbles are discharged from the pump where they collapse on downstream piping and cause localized water hammers.

ANSWER: B.

TOPIC: 291004
KNOWLEDGE: K1.01 [3.2/3.2]
QID: B1718 (P1820)

By starting a centrifugal pump with the discharge valve throttled versus fully open, the possibility of pump runout is _____, and the possibility of pump cavitation is _____.

- A. increased; decreased
- B. increased; increased
- C. decreased; decreased
- D. decreased; increased

ANSWER: C.

TOPIC: 291004
KNOWLEDGE: K1.01 [3.2/3.2]
QID: B2118 (P1021)

Which one of the following will result in immediate cavitation of a centrifugal pump that is initially operating at normal rated flow?

- A. Recirculation flow path is aligned.
- B. Recirculation flow path is isolated.
- C. Pump suction valve is fully closed.
- D. Pump discharge valve is fully closed.

ANSWER: C.

TOPIC: 291004
KNOWLEDGE: K1.02 [2.8/2.8]
QID: B18

Venting a centrifugal pump prior to operating it ensures that...

- A. pump runout will not occur.
- B. pump internal corrosion is reduced.
- C. gas binding is reduced.
- D. starting load is minimized.

ANSWER: C.

TOPIC: 291004
KNOWLEDGE: K1.02 [2.8/2.8]
QID: B219

Gas binding in a centrifugal pump can be prevented by _____ prior to pump start.

- A. venting the pump
- B. lowering suction pressure
- C. throttling the discharge valve
- D. shutting the discharge valve

ANSWER: A.

TOPIC: 291004
KNOWLEDGE: K1.02 [2.8/2.8]
QID: B1821 (P1927)

Which one of the following is an effective method for ensuring that a centrifugal pump remains primed and does not become gas bound during operation and after shutdown?

- A. Install the pump below the level of the suction supply.
- B. Install a check valve in the discharge piping of the pump.
- C. Install an orifice plate in the discharge piping of the pump.
- D. Install a pump recirculation line from the pump discharge piping to the pump suction piping.

ANSWER: A.

TOPIC: 291004
KNOWLEDGE: K1.03 [2.8/2.9]
QID: B518

Which one of the following describes gas binding of a centrifugal pump?

- A. Pump capacity is reduced due to the presence of steam or air in the pump impeller.
- B. Pump capacity is reduced due to windage losses between the pump impeller and pump casing.
- C. Pump motor current increases due to the compression of gases in the pump volute.
- D. Pump motor current increases due to the high head requirements for pumping a fluid saturated with dissolved gases.

ANSWER: A.

TOPIC: 291004
KNOWLEDGE: K1.04 [3.0/3.1]
QID: B19

Which one of the following would result from operating a motor-driven centrifugal pump for extended periods of time with the discharge valve shut and no recirculation flow?

- A. No damage, because the pump and motor are designed to operate with the discharge valve shut
- B. Pump overheating, cavitating, and ultimately pump failure
- C. Excessive motor current, damage to motor windings, and ultimately motor failure
- D. Pump and motor overspeed and tripping on high motor current

ANSWER: B.

TOPIC: 291004
KNOWLEDGE: K1.04 [3.0/3.1]
QID: B319 (P321)

A motor-driven centrifugal pump with no recirculation flow path must be stopped when discharge pressure reaches the pump shutoff head to prevent...

- A. overheating of the pump.
- B. overheating of the motor.
- C. bursting of the pump casing.
- D. water hammer in downstream lines.

ANSWER: A.

TOPIC: 291004
KNOWLEDGE: K1.04 [3.0/3.1]
QID: B423 (P23)

Operating a motor-driven centrifugal pump for an extended period of time under no flow conditions will cause...

- A. pump failure from overspeed.
- B. pump failure from overheating.
- C. motor failure from overspeed.
- D. motor failure from overheating.

ANSWER: B.

TOPIC: 291004
KNOWLEDGE: K1.04 [3.0/3.1]
QID: B1219 (P2221)

Refer to the drawing of a pump with a recirculation line (see figure below).

Valve "A" will open when pump...

- A. discharge pressure increases above a setpoint.
- B. discharge pressure decreases below a setpoint.
- C. flow rate increases above a setpoint.
- D. flow rate decreases below a setpoint.

ANSWER: D.

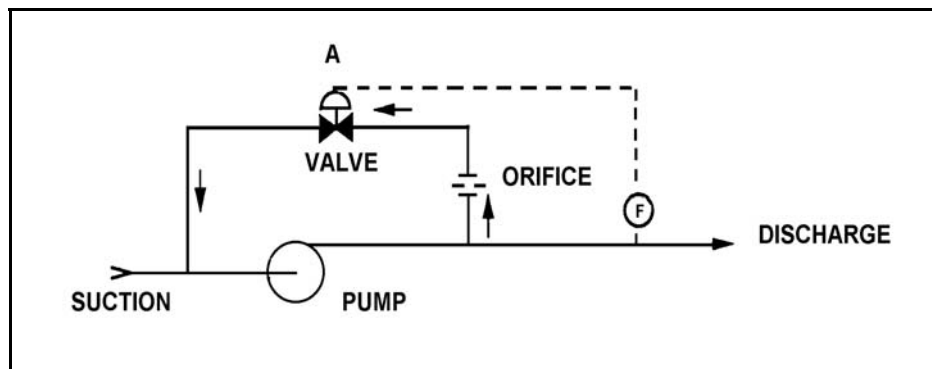

TOPIC: 291004
KNOWLEDGE: K1.04 [3.0/3.1]
QID: B1319 (P119)

Refer to the drawing of centrifugal pump and system operating curves (see figure below).

Which point represents pump operation at shutoff head?

- A. Point A
- B. Point B
- C. Point C
- D. Point D

ANSWER: A.

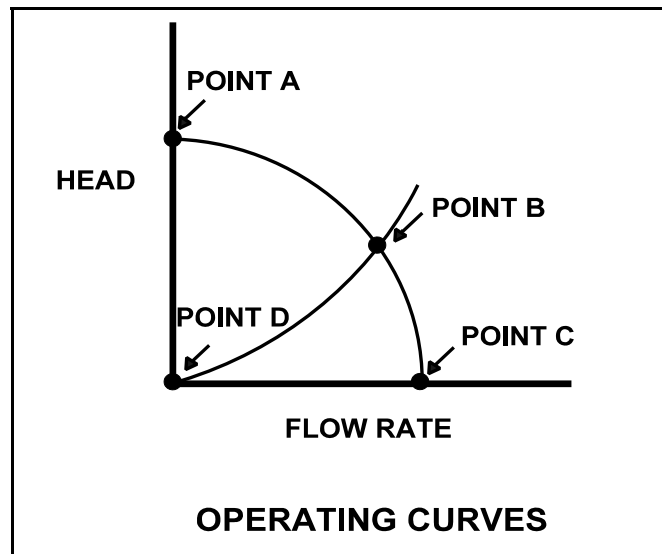

TOPIC: 291004
KNOWLEDGE: K1.04 [3.0/3.1]
QID: B1917 (P1320)

Refer to the drawing of a pump with recirculation line (see figure below).

The flowpath through valve A is designed to...

- A. prevent pump runout by creating a recirculation flowpath.
- B. provide a small flow rate through the pump during shutoff head conditions.
- C. direct a small amount of water to the pump suction to raise available net positive suction head.
- D. prevent the discharge piping from exceeding design pressure during no-flow conditions.

ANSWER: B.

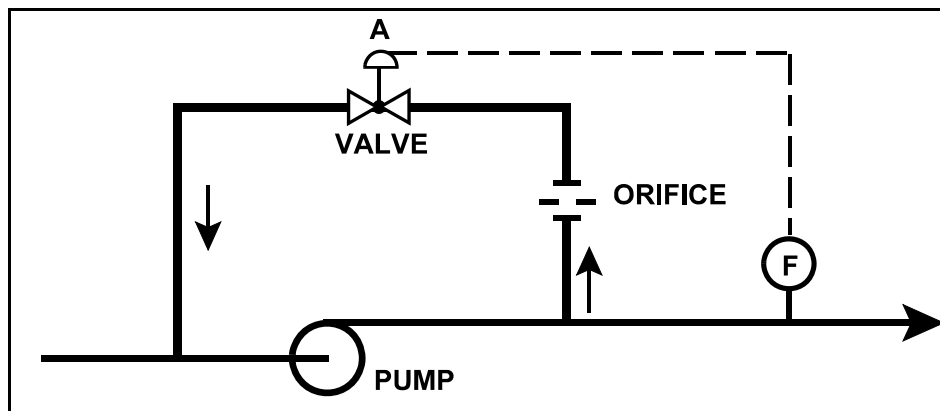

TOPIC: 291004
KNOWLEDGE: K1.04 [3.0/3.1]
QID: B2017 (P2019)

Refer to the drawing of a pump with recirculation line (see figure below).

Which one of the following describes the response of the pump if a complete flow blockage occurs in the discharge line just downstream of the flow transmitter?

- A. The pump will overheat after a relatively short period of time due to a loss of both main flow and recirculation flow.
- B. The pump will overheat after a relatively long period of time due to a loss of main flow only.
- C. The pump will overheat after a relatively long period of time due to a loss of recirculation flow only.
- D. The pump will be able to operate under these conditions indefinitely due to sustained main flow.

ANSWER: B.

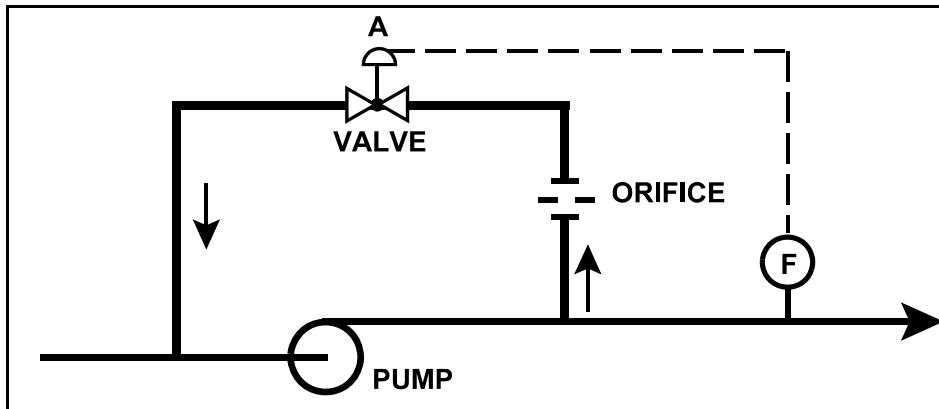

TOPIC: 291004
KNOWLEDGE: K1.04 [3.0/3.1]
QID: B2225 (P3122)

Refer to the drawing of a pump with a recirculation line (see figure below).

Valve "A" will close when pump...

- A. discharge pressure increases above a setpoint.
- B. discharge pressure decreases below a setpoint.
- C. flow rate increases above a setpoint.
- D. flow rate decreases below a setpoint.

ANSWER: C.

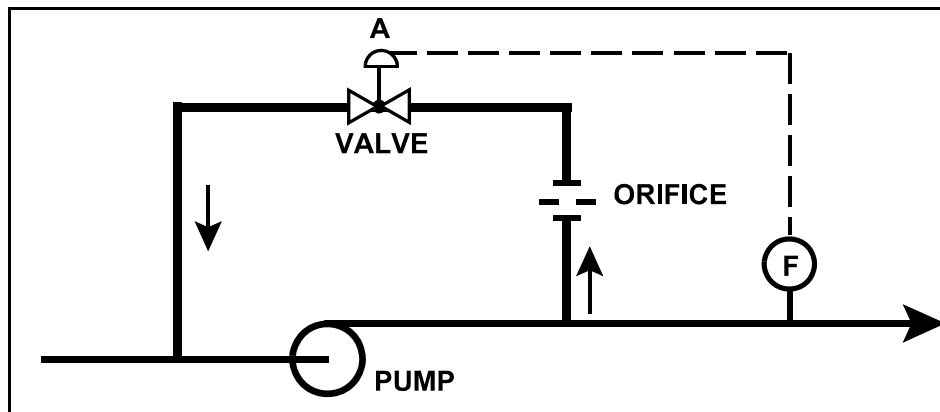

TOPIC: 291004
KNOWLEDGE: K1.05 [2.8/2.9]
QID: B20

A centrifugal pump is operating at rated speed with an output head of 240 psig. The speed of the pump is then decreased until the power consumption is 1/64 of its original value. What is the approximate new output head?

- A. 3.75 psig
- B. 15 psig
- C. 30 psig
- D. 60 psig

ANSWER: B.

TOPIC: 291004
KNOWLEDGE: K1.05 [2.8/2.9]
QID: B102

The discharge head of a centrifugal pump will decrease if the...

- A. pump suction pressure is increased.
- B. speed of the pump increases.
- C. discharge valve is throttled closed.
- D. temperature of the fluid being pumped increases.

ANSWER: D.

TOPIC: 291004
KNOWLEDGE: K1.05 [2.8/2.9]
QID: B106

A multi-speed centrifugal pump is operating at 1800 rpm, providing a flow of 400 gpm at 20 psig. If the pump speed is increased to 3600 rpm, the new pump discharge pressure will be...

- A. 160 psig.
- B. 80 psig.
- C. 60 psig.
- D. 40 psig.

ANSWER: B.

TOPIC: 291004
KNOWLEDGE: K1.05 [2.8/2.9]
QID: B112

A variable-speed centrifugal pump is running with its drive motor at 1,800 rpm. The initial flow rate is 1,000 gpm, total head is 100 feet, and work input is 500 hp.

If the flow rate is changed to 1,200 gpm, which one of the following will be the correct value for new work input?

- A. 550 hp
- B. 778 hp
- C. 864 hp
- D. 912 hp

ANSWER: C.

TOPIC: 291004
KNOWLEDGE: K1.05 [2.8/2.9]
QID: B1020 (P3323)

Refer to the drawing of a cooling water system and the associated pump/system operating curves (see figure below). Pumps A and B are identical single-speed centrifugal pumps and initially only pump A is operating.

Pump B is then started. After the system stabilizes, system flow rate will be...

- A. the same as the initial flow rate.
- B. less than twice the initial flow rate.
- C. twice the initial flow rate.
- D. more than twice the initial flow rate.

ANSWER: B.

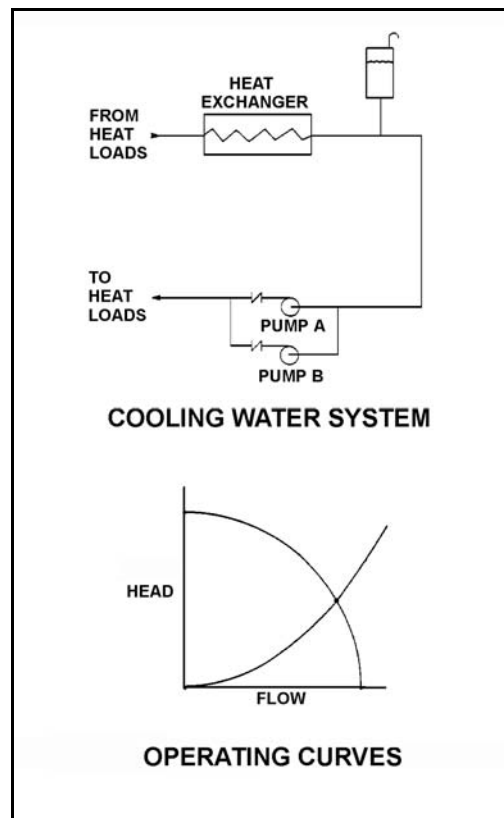

TOPIC: 291004
KNOWLEDGE: K1.05 [2.8/2.9]
QID: B1221

A centrifugal pump is operating with the following parameters:

Pump head: 50 psid
Flow rate: 200 gpm
Power input: 3 KW

Pump speed is increased and flow rate increases to 400 gpm. Which one of the following is the value of the new power consumption?

- A. 6 KW
- B. 9 KW
- C. 24 KW
- D. 27 KW

ANSWER: C.

TOPIC: 291004
KNOWLEDGE: K1.05 [2.8/2.9]
QID: B1320

The discharge head of a variable-speed centrifugal pump will increase if the...

- A. pump suction pressure is increased.
- B. speed of the pump decreases.
- C. pump discharge valve is opened farther.
- D. temperature of the fluid being pumped increases.

ANSWER: A.

TOPIC: 291004
KNOWLEDGE: K1.05 [2.8/2.9]
QID: B1519

An AC motor-driven centrifugal pump is operating with the following parameters:

Flow rate: 300 gpm
Power input: 4 KW

Pump speed is increased and flow rate increases to 400 gpm.

Which one of the following is the approximate value of the new power consumption?

- A. 5.3 KW
- B. 7.1 KW
- C. 9.5 KW
- D. 11.7 KW

ANSWER: C.

TOPIC: 291004
KNOWLEDGE: K1.05 [2.8/2.9]
QID: B1619

A multi-speed centrifugal pump is operating with a flow rate of 3,000 gpm. Which one of the following approximates the new flow rate if the speed is decreased from 3,600 rpm to 2,400 rpm?

- A. 1,000 gpm
- B. 1,500 gpm
- C. 2,000 gpm
- D. 2,500 gpm

ANSWER: C.

TOPIC: 291004
KNOWLEDGE: K1.05 [2.8/2.9]
QID: B1719

A centrifugal pump is operating with the following parameters:

Speed = 1,800 rpm
Current = 40 amps
Pump head = 20 psi
Pump flow rate = 400 gpm

Which one of the following contains the approximate values of pump head and current if pump speed is decreased to 1,200 rpm?

- A. 13 psi, 18 amps
- B. 13 psi, 12 amps
- C. 9 psi, 18 amps
- D. 9 psi, 12 amps

ANSWER: D.

TOPIC: 291004
KNOWLEDGE: K1.05 [2.8/2.9]
QID: B2321 (P2329)

A multi-speed centrifugal pump is operating at 3,600 rpm with a flow rate of 3,000 gpm. Which one of the following approximates the new flow rate if the speed is decreased to 3,000 rpm?

- A. 1,000 gpm
- B. 1,500 gpm
- C. 2,000 gpm
- D. 2,500 gpm

ANSWER: D.

TOPIC: 291004
KNOWLEDGE: K1.05 [2.8/2.9]
QID: B2419 (P2424)

A centrifugal pump is operating with the following parameters:

Pump head: 60 psid
Flow rate: 300 gpm
Power input: 4 KW

Pump speed is increased and flow rate increases to 400 gpm.

Which one of the following is the approximate value of the new power consumption?

- A. 5.3 KW
- B. 7.1 KW
- C. 9.5 KW
- D. 11.7 KW

ANSWER: C.

TOPIC: 291004
KNOWLEDGE: K1.05 [2.8/2.9]
QID: B2718 (P2723)

Refer to the drawing showing two operating points for the same centrifugal pump (see figure below).

Operating point A was generated from pump performance data taken six months ago. Current pump performance data was used to generate operating point B. Which one of the following would cause the observed difference between operating points A and B?

- A. The pump discharge valve was more open when data was collected for operating point A.
- B. The pump discharge valve was more closed when data was collected for operating point A.
- C. The pump internal components have worn since data was collected for operating point A.
- D. The system piping head loss has increased since data was collected for operating point A.

ANSWER: C.

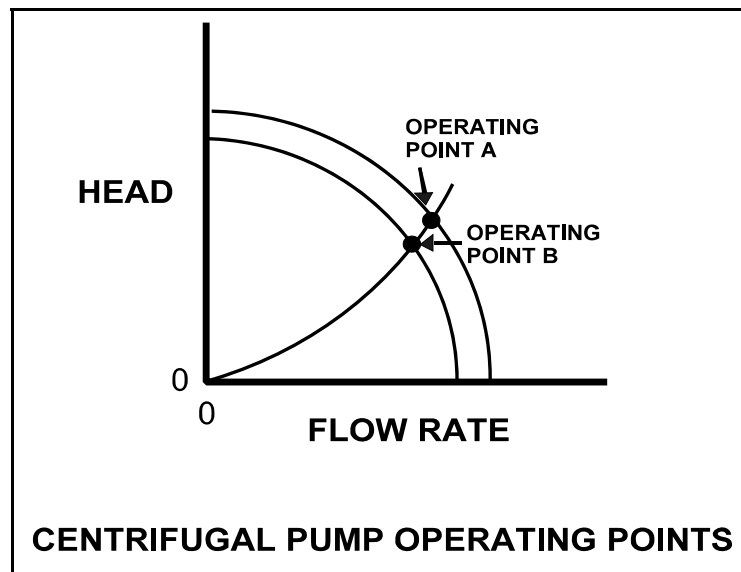

TOPIC: 291004
KNOWLEDGE: K1.05 [2.8/2.9]
QID: B3419 (P1429)

A variable-speed centrifugal pump is driven by an AC motor with the following initial conditions:

Pump speed = 400 rpm
Motor current = 40 amps
Pump head = 60 psid

If pump speed is increased to 1,600 rpm what will be the new pump head?

- A. 240 psid
- B. 480 psid
- C. 960 psid
- D. 1,440 psid

ANSWER: C.

TOPIC: 291004
KNOWLEDGE: K1.05 [2.8/2.9]
QID: B4211 (P4211)

Refer to the drawing of an operating cooling water system (see figure below). As depicted in the drawing, only two of the three system heat loads are currently in service.

Which one of the following changes to the cooling water system will result in a higher cooling water pump flow rate and a reduced pump discharge head?

- A. Increase pump speed by 20 percent.
- B. Decrease pump speed by 20 percent.
- C. Isolate one of the two in-service heat loads.
- D. Place the third system heat load in service.

ANSWER: D.

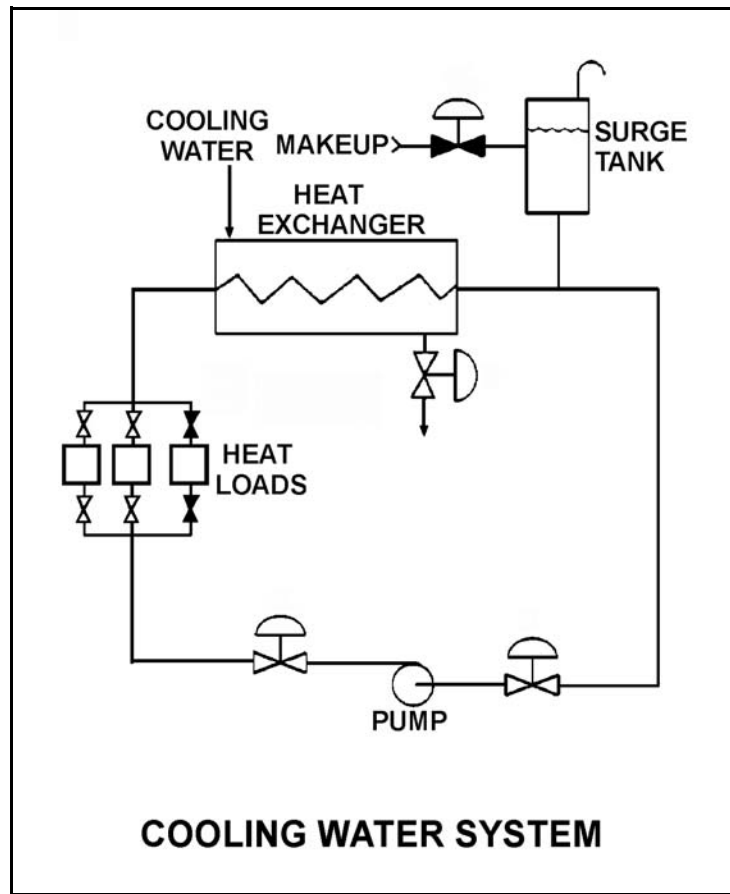

TOPIC: 291004
KNOWLEDGE: K1.06 [3.3/3.3]
QID: B21

Which one of the following will increase reactor recirculation pump available net positive suction head? (Assume all other parameters remain constant.)

- A. Loss of feedwater heating while at 80 percent power
- B. Increase in reactor coolant temperature from 100°F to 200°F during a reactor startup
- C. Decrease in reactor pressure during a normal reactor shutdown
- D. Decrease in reactor water level from the normal level to just below the low-level alarm level

ANSWER: A.

TOPIC: 291004
KNOWLEDGE: K1.06 [3.3/3.3]
QID: B25

What will occur by operating a positive displacement pump with insufficient net positive suction head?

- A. Slip
- B. Decreased pump speed
- C. Water hammer
- D. Vapor binding

ANSWER: D.

TOPIC: 291004
KNOWLEDGE: K1.06 [3.3/3.3]
QID: B121 (P1120)

Which one of the following operations in a closed system will cause a decrease in available net positive suction head for a centrifugal pump?

- A. Decreasing the inlet fluid temperature
- B. Increasing the pump discharge pressure
- C. Throttling open the pump suction valve
- D. Throttling open the pump discharge valve

ANSWER: D.

TOPIC: 291004
KNOWLEDGE: K1.06 [3.3/3.3]
QID: B222

Which one of the following conditions will result in a decrease in the available net positive suction head of a reactor recirculation pump?

- A. Carryunder decreases.
- B. Feedwater flow increases.
- C. Recirculation flow rate increases.
- D. Feedwater inlet subcooling increases.

ANSWER: C.

TOPIC: 291004
KNOWLEDGE: K1.06 [3.3/3.3]
QID: B720

Which one of the following will decrease the available net positive suction head to the reactor recirculation pumps? (Assume all other parameters remain constant.)

- A. Increase in reactor water level from the normal level to just below the high-level alarm
- B. Increase in reactor coolant temperature from 100°F to 200°F during a reactor startup
- C. Increase in reactor pressure during a reactor startup
- D. Loss of feedwater heating while at 80 percent power

ANSWER: B.

TOPIC: 291004
KNOWLEDGE: K1.06 [3.3/3.3]
QID: B1120

When flow from a centrifugal pump is increased by opening the discharge valve further, required net positive suction head (NPSH) _____, and available NPSH _____.

- A. decreases; decreases
- B. decreases; increases
- C. increases; increases
- D. increases; decreases

ANSWER: D.

TOPIC: 291004
KNOWLEDGE: K1.06 [3.3/3.3]
QID: B1222

Which one of the following changes in nuclear power plant status will bring the reactor recirculation system closer to the condition in which the recirculation pump will cavitate?

- A. During a plant shutdown, reactor recirculation pump suction temperature decreases while reactor pressure remains constant.
- B. Reactor recirculation pump speed is increased.
- C. Reactor water level increases.
- D. Extraction steam is isolated from one high-pressure feed water heater during power operations.

ANSWER: B.

TOPIC: 291004
KNOWLEDGE: K1.06 [3.3/3.3]
QID: B1621 (P1221)

Refer to the drawing of a cooling water system (see figure below).

The available net positive suction head for the centrifugal pump will be increased by...

- A. opening surge tank makeup valve "A" to raise tank level.
- B. throttling heat exchanger service water valve "B" more closed.
- C. throttling pump discharge valve "C" more open.
- D. throttling pump suction valve "D" more closed.

ANSWER: A.

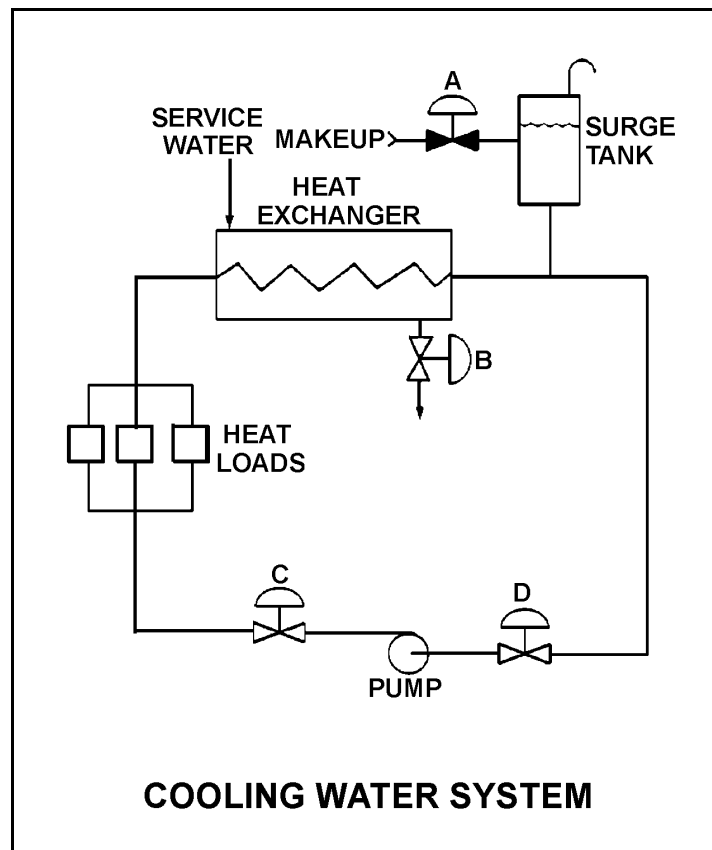

TOPIC: 291004
KNOWLEDGE: K1.06 [3.3/3.3]
QID: B1918 (P1521)

Refer to the drawing of a cooling water system (see figure below).

The available net positive suction head for the centrifugal pump will be decreased by...

- A. opening surge tank makeup valve "A" to raise tank level.
- B. throttling heat exchanger service water valve "B" more open.
- C. throttling pump discharge valve "C" more open.
- D. reducing the heat load on the cooling water system.

ANSWER: C.

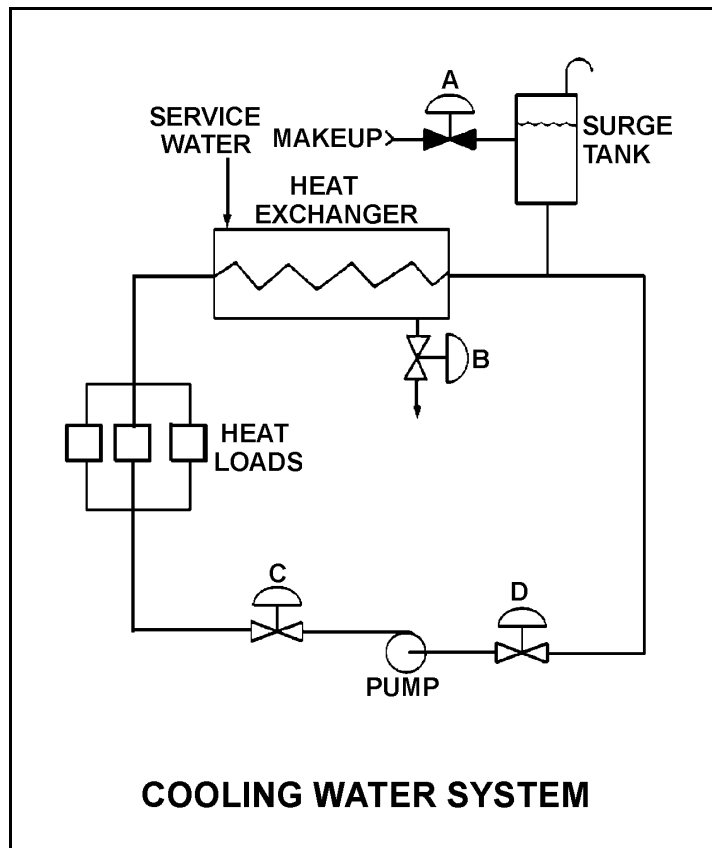

TOPIC: 291004
KNOWLEDGE: K1.06 [3.3/3.3]
QID: B2019 (P2025)

A variable-speed centrifugal pump is operating at rated speed in an open system. If the pump speed is decreased by 50 percent, available net positive suction head (NPSH) will _____ and required NPSH will _____.

- A. increase; decrease
- B. increase; remain the same
- C. decrease; decrease
- D. decrease; remain the same

ANSWER: A.

TOPIC: 291004
KNOWLEDGE: K1.06 [3.3/3.3]
QID: B2119 (P1822)

Refer to the drawing of an operating cooling water system (see figure below).

Which one of the following will increase available net positive suction head for the centrifugal pump?

- A. Draining the surge tank to decrease level by 10 percent.
- B. Positioning heat exchanger service water valve "B" more closed.
- C. Positioning pump discharge valve "C" more closed.
- D. Positioning pump suction valve "D" more closed.

ANSWER: C.

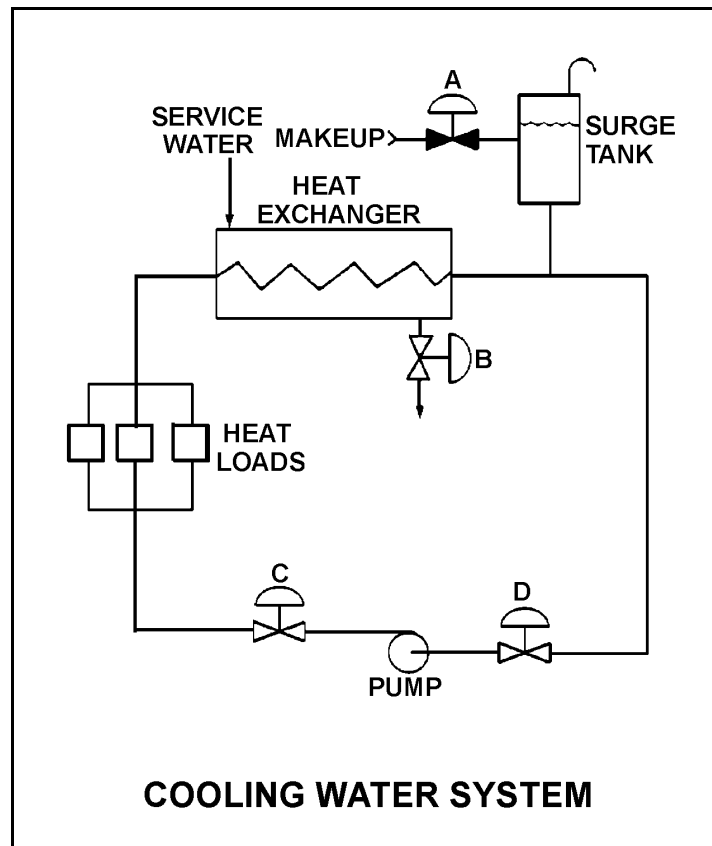

TOPIC: 291004
KNOWLEDGE: K1.06 [3.3/3.3]
QID: B2223 (P114)

A motor-driven centrifugal pump is operating in an open system with its discharge valve throttled to 50 percent open. If the discharge valve is fully opened, available net positive suction head (NPSH) will _____ and required NPSH will _____.

- A. remain the same; increase
- B. remain the same; remain the same
- C. decrease; increase
- D. decrease; remain the same

ANSWER: C.

TOPIC: 291004
KNOWLEDGE: K1.06 [3.3/3.3]
QID: B2420 (P2424)

A variable speed motor-driven centrifugal pump is operating at 50 percent speed in an open system. If the pump speed is increased to 100 percent, available net positive suction head (NPSH) will _____ and required NPSH will _____.

- A. increase; remain the same
- B. increase; increase
- C. decrease; remain the same
- D. decrease; increase

ANSWER: D.

TOPIC: 291004
KNOWLEDGE: K1.06 [3.3/3.3]
QID: B2518 (P2222)

Refer to the drawing of a cooling water system (see figure below).

The available net positive suction head for the centrifugal pump will be decreased by...

- A. increasing surge tank level by 5 percent.
- B. throttling heat exchanger service water valve "B" more open.
- C. throttling pump discharge valve "C" more closed.
- D. increasing the heat loads on the cooling water system.

ANSWER: D.

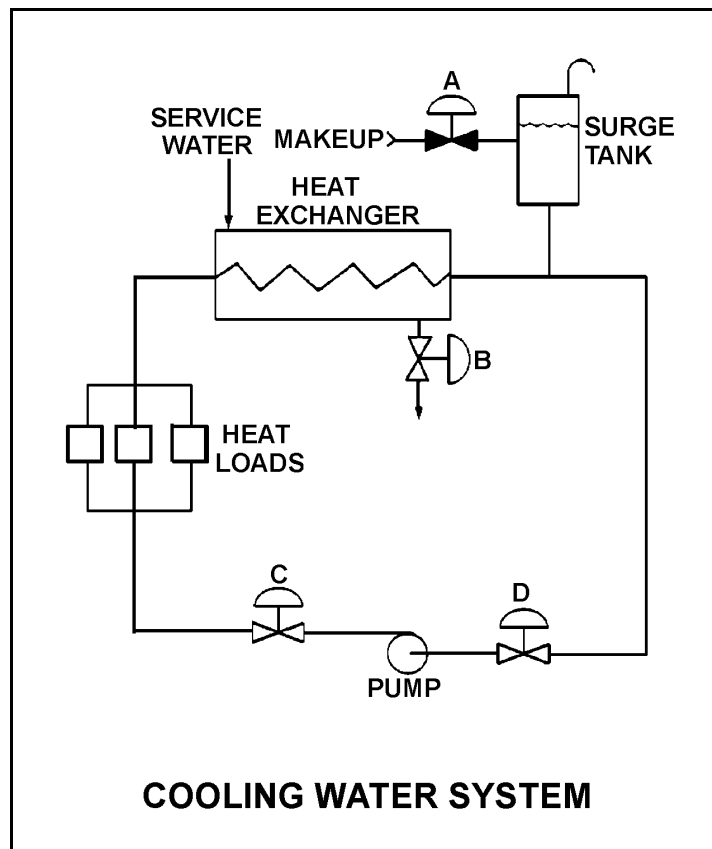

TOPIC: 291004
KNOWLEDGE: K1.06 [3.3/3.3]
QID: B2621 (P2621)

A cooling water pump is operating with pump suction parameters as follows:

Suction Temperature: 124°F
Suction Pressure: 11.7 psia

What is the approximate available net positive suction head (NPSH) for the pump? (Neglect the contribution of the suction fluid velocity to NPSH.)

- A. 23 feet
- B. 27 feet
- C. 31 feet
- D. 35 feet

ANSWER: A.

TOPIC: 291004
KNOWLEDGE: K1.06 [3.3/3.3]
QID: B2920 (P2921)

Refer to the drawing of an operating cooling water system (see figure below).

Which one of the following will increase the available net positive suction head for the centrifugal pump?

- A. Draining the surge tank to decrease level by 10 percent.
- B. Positioning the service water valve "B" more closed.
- C. Positioning the pump discharge valve "C" more open.
- D. Reducing the heat loads on the cooling water system.

ANSWER: D.

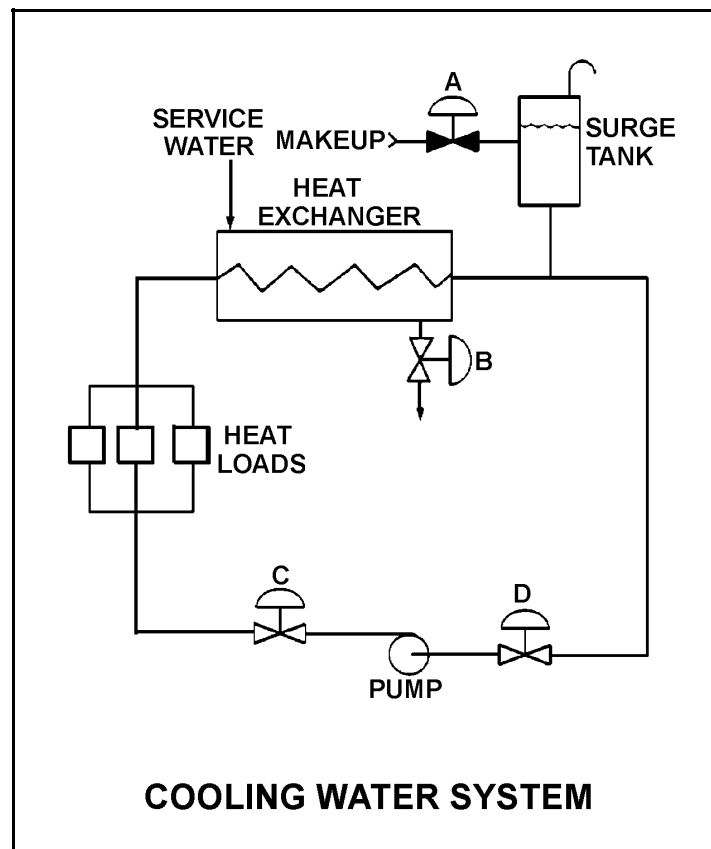

TOPIC: 291004
KNOWLEDGE: K1.06 [3.3/3.3]
QID: B3219 (P3221)

A centrifugal pump is taking suction on an open storage tank that has been filled to a level of 40 feet with 10,000 gallons of 60°F water. The pump is located at the base of the tank, takes a suction from the bottom of the tank, and discharges to a lake.

Given:

- The pump is currently operating at its design flow rate of 200 gpm and a total developed head of 150 feet.
- The pump requires 4 feet of net positive suction head.

How will the centrifugal pump flow rate be affected as the water storage tank level decreases?

- A. Flow rate will remain constant until the pump begins to cavitate at a tank level of about 4 feet.
- B. Flow rate will remain constant until the pump becomes air bound when the tank empties.
- C. Flow rate will gradually decrease until the pump begins to cavitate at a tank level of about 4 feet.
- D. Flow rate will gradually decrease until the pump becomes air bound when the tank empties.

ANSWER: D.

TOPIC: 291004
KNOWLEDGE: K1.06 [3.3/3.3]
QID: B4011 (P4010)

Refer to the drawing below of a centrifugal pump taking suction from the bottom of an open storage tank containing water at 66°F. Pump and water level elevations are indicated in the figure. Assume standard atmospheric pressure.

Assuming that pump suction head loss is negligible, what is the approximate value of net positive suction head available to the pump.

- A. 6 feet
- B. 13 feet
- C. 20 feet
- D. 25 feet

ANSWER: C.

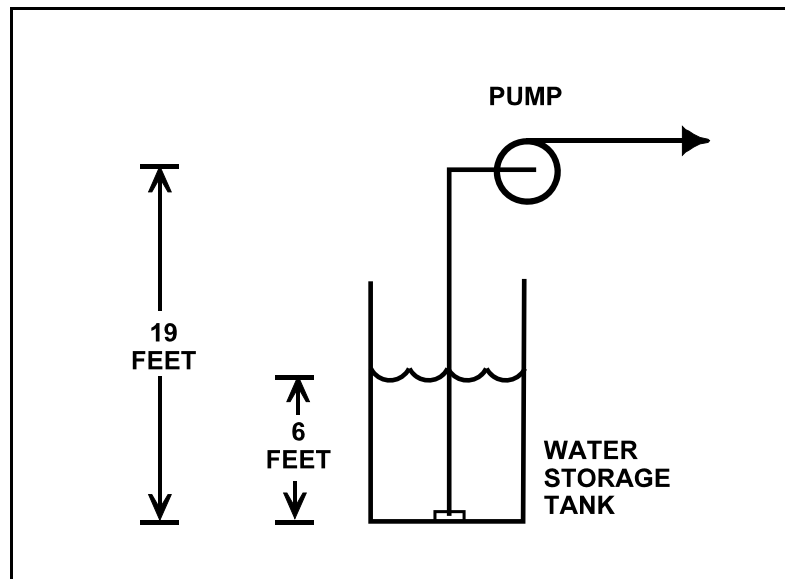

TOPIC: 291004
KNOWLEDGE: K1.06 [3.3/3.3]
QID: B4113 (P4110)

Refer to the drawing of an elevated centrifugal pump taking suction from the bottom of an open storage tank containing water at 66°F (see figure below). Assume standard atmospheric pressure.

The pump requires 4.0 ft-lbf/lbm of net positive suction head (NPSH). Assume that pump suction head loss is negligible.

If tank water level is allowed to decrease continuously, at what approximate water level will the pump begin to cavitate?

- A. 34 feet
- B. 29 feet
- C. 21 feet
- D. 16 feet

ANSWER: C.

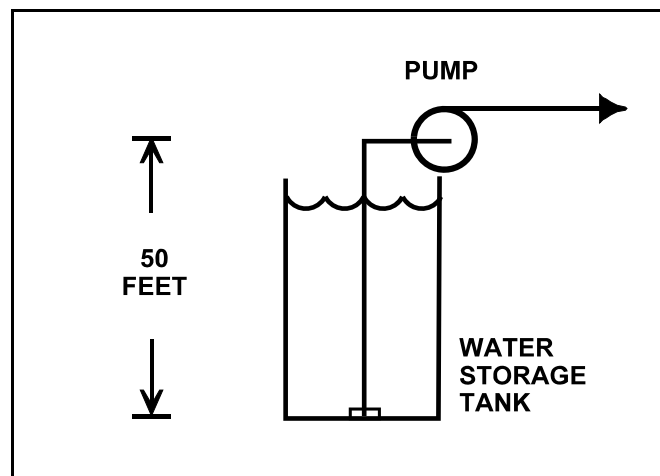

TOPIC: 291004
KNOWLEDGE: K1.06 [3.3/3.3]
QID: B4410 (P4410)

Refer to the drawing below of a centrifugal pump taking suction from the bottom of an open storage tank containing water at 66°F. Pump and water level elevations are indicated in the figure. Assume standard atmospheric pressure.

Assuming that pump suction head loss is negligible, what is the approximate value of net positive suction head available to the pump.

- A. 6 feet
- B. 12 feet
- C. 39 feet
- D. 45 feet

ANSWER: D.

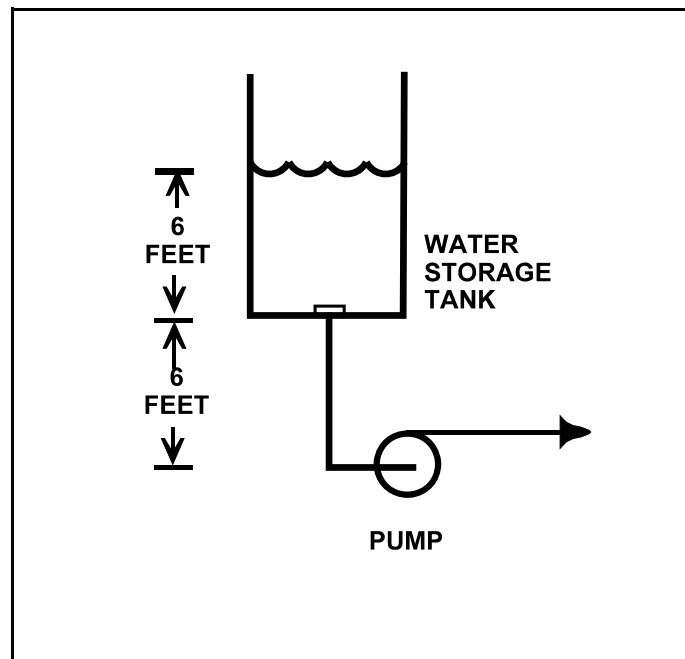

TOPIC: 291004
KNOWLEDGE: K1.06 [3.3/3.3]
QID: B4710 (P4712)

A motor-driven centrifugal cooling water pump is operating in an open system with its discharge valve fully open. If the discharge valve is repositioned to 50 percent open, the pump's available net positive suction head (NPSH) will _____ and the pump's required NPSH will _____.

- A. remain the same; decrease
- B. remain the same; remain the same
- C. increase; decrease
- D. increase; remain the same

ANSWER: C.

TOPIC: 291004
KNOWLEDGE: K1.06 [3.3/3.3]
QID: B5210 (P5211)

Consider a centrifugal pump that is taking suction from the bottom of an open water storage tank.
(See figure below.)

Given:

The tank contains 60°F water.

The eye of the pump impeller is located 50 feet above the bottom of the tank.

The pump requires a minimum net positive suction head of 4 feet.

Which one of the following describes the effect on pump operation if tank water level is allowed to continuously decrease?

- A. The pump will operate normally until tank water level decreases below approximately 20 feet, at which time the pump will cavitate.
- B. The pump will operate normally until tank water level decreases below approximately 16 feet, at which time the pump will cavitate.
- C. The pump will operate normally until the pump suction becomes uncovered, at which time the pump will cavitate.
- D. The pump will operate normally until the pump suction becomes uncovered, at which time the pump will become air bound.

ANSWER: A.

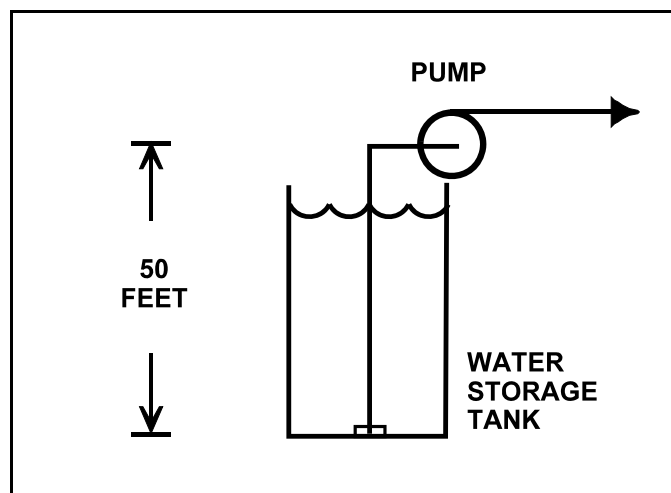

TOPIC: 291004
KNOWLEDGE: K1.06 [3.3/3.3]
QID: B5510 (P5511)

Refer to the drawing of a steam condenser, hotwell, and condensate pump (see figure below).

Given the following:

- The eye of the pump impeller is located 6.0 feet below the bottom of the hotwell.
- The pump requires 10.0 ft-lbf/lbm of net positive suction head (NPSH).
- Condenser pressure is 1.2 psia.
- Hotwell water temperature is 90°F.
- Pump suction head losses are zero.

What is the minimum hotwell water level necessary to provide the required NPSH?

- A. 1.2 feet
- B. 2.8 feet
- C. 4.0 feet
- D. 5.2 feet

ANSWER: B.

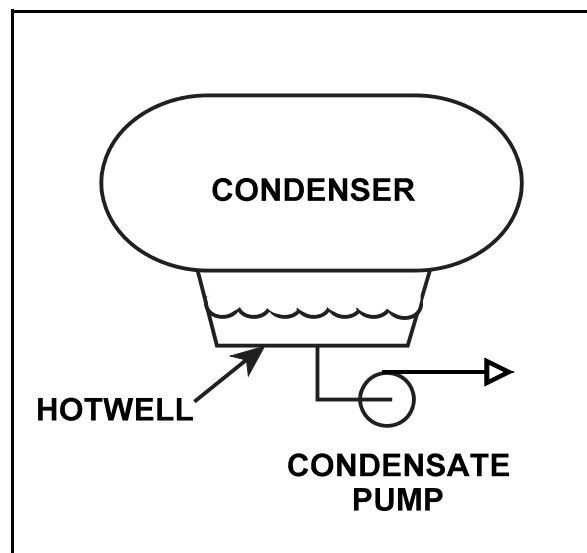

TOPIC: 291004
KNOWLEDGE: K1.06 [3.3/3.3]
QID: B5610 (P5611)

A centrifugal pump is taking suction on a water storage tank and delivering the makeup water to a cooling water system. The pump will have the lowest net positive suction head requirement if the pump is operated at a relatively _____ speed with a _____ discharge flow control valve.

- A. high; fully open
- B. high; throttled
- C. low; fully open
- D. low; throttled

ANSWER: D.

TOPIC: 291004
KNOWLEDGE: K1.06 [3.3/3.3]
QID: B5810 (P5810)

Refer to the drawing below of a centrifugal pump taking suction from the bottom of an open storage tank containing water at 75°F. Pump and water level elevations are indicated in the figure. Assume standard atmospheric pressure.

Assuming that pump suction head loss is negligible, what is the approximate value of net positive suction head available to the pump.

- A. 5 feet
- B. 10 feet
- C. 17 feet
- D. 23 feet

ANSWER: D.

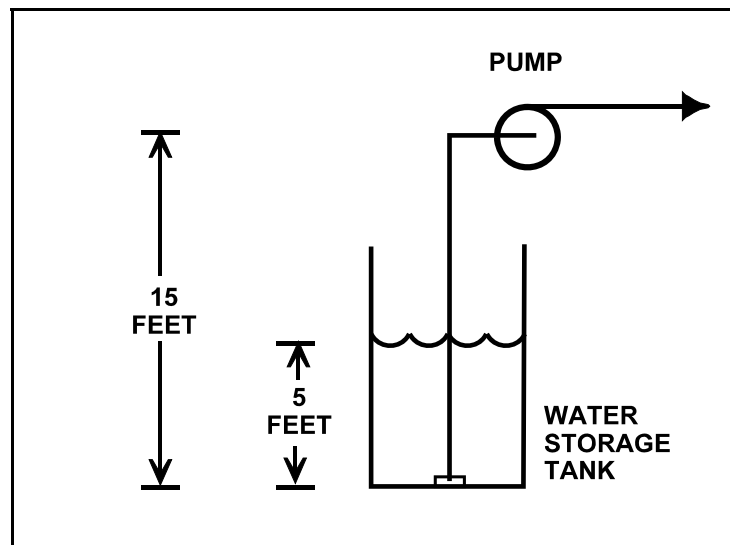

TOPIC: 291004
KNOWLEDGE: K1.06 [3.3/3.3]
QID: B5911 (P5910)

Refer to the drawing of a steam condenser, hotwell, and condensate pump (see figure below).

Given the following initial conditions:

- Condenser pressure is 1.2 psia.
- Condensate temperature is 96°F.
- Hotwell level is 10 feet above the condensate pump suction.

Which one of the following will provide the greatest increase in NPSH available to the condensate pump? (Assume that condenser pressure does not change.)

- A. Hotwell level decreases by 6 inches.
- B. Hotwell level increases by 6 inches.
- C. Condensate temperature decreases by 6°F.
- D. Condensate temperature increases by 6°F.

ANSWER: B.

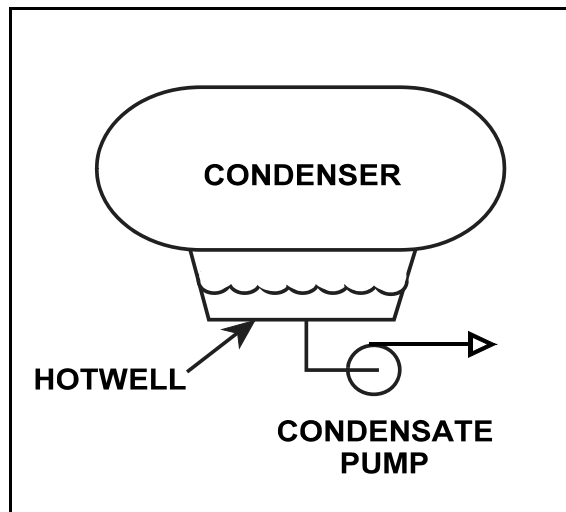

TOPIC: 291004
KNOWLEDGE: K1.06 [3.3/3.3]
QID: B6211 (P6211)

A centrifugal pump is taking suction on a water storage tank and discharging through a flow control valve. The pump will have the highest net positive suction head requirement if the pump is operated at a _____ speed with a _____ discharge flow control valve.

- A. high; fully open
- B. high; throttled
- C. low; fully open
- D. low; throttled

ANSWER: A

TOPIC: 291004
KNOWLEDGE: K1.06 [3.3/3.3]
QID: B6410 (P6410)

An operating centrifugal pump has a net positive suction head (NPSH) requirement of 150 ft-lbf/lbm. Water at 300°F is entering the pump. Which one of the following is the lowest listed pump inlet pressure that will ensure adequate NPSH for the pump?

- A. 60 psia
- B. 83 psia
- C. 108 psia
- D. 127 psia

ANSWER: D.

TOPIC: 291004
KNOWLEDGE: K1.06 [3.3/3.3]
QID: B6510 (P6510)

Refer to the drawing of a steam condenser, hotwell, and condensate pump (see figure below).

Given the following:

- The eye of the pump impeller is located 6.0 feet below the bottom of the hotwell.
- Hotwell water level is 6.0 feet.
- Hotwell water temperature is 90°F.
- Condenser pressure is 1.3 psia.
- Fluid velocity and friction head losses are zero.

What is the net positive suction head available to the condensate pump?

- A. 6.0 feet
- B. 7.4 feet
- C. 12.0 feet
- D. 13.4 feet

ANSWER: D.

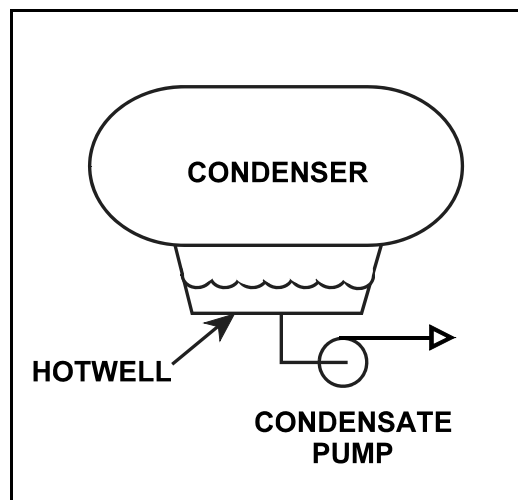

TOPIC: 291004
KNOWLEDGE: K1.06 [3.3/3.3]
QID: B6811 (P6810)

The current conditions for a centrifugal water pump are as follows:

Pump suction pressure: 140 psia
Pump suction temperature: 300°F

The pump requires a net positive suction head (NPSH) of 150 ft-lbf/lbm for pumping water at 300°F. Which one of the following is the lowest pump suction pressure that will provide the required NPSH for the current conditions?

- A. 132 psia
- B. 127 psia
- C. 73 psia
- D. 67 psia

ANSWER: B.

TOPIC: 291004
KNOWLEDGE: K1.07 [2.8/2.8]
QID: B115 (P1924)

A constant-speed radial-flow centrifugal pump motor draws the least current when the pump is...

- A. at maximum rated flow conditions.
- B. operating on recirculation flow only.
- C. accelerating to normal speed during start.
- D. at shutoff head with no recirculation flow.

ANSWER: D.

TOPIC: 291004
KNOWLEDGE: K1.07 [2.8/2.8]
QID: B119

A centrifugal pump is initially operating at normal discharge pressure and flow conditions with the pump discharge valve fully open. Then, the discharge valve is throttled to the 50 percent open position. Which one of the following parameter changes will occur when the discharge valve is throttled?

- A. Pump motor current decreases.
- B. Pump flow rate increases.
- C. Pump discharge head decreases.
- D. Available net positive suction head decreases.

ANSWER: A.

TOPIC: 291004
KNOWLEDGE: K1.07 [2.8/2.8]
QID: B419 (P424)

Refer to the drawing of a cooling water system (see figure below).

The centrifugal pump is circulating water at 100°F. After several hours the water temperature has increased to 200°F. Assuming system flow rate (gpm) is constant, pump motor amps will have _____ because _____.

- A. decreased; water density has decreased
- B. increased; water density has decreased
- C. decreased; pump shaft speed has increased
- D. increased; pump shaft speed has increased

ANSWER: A.

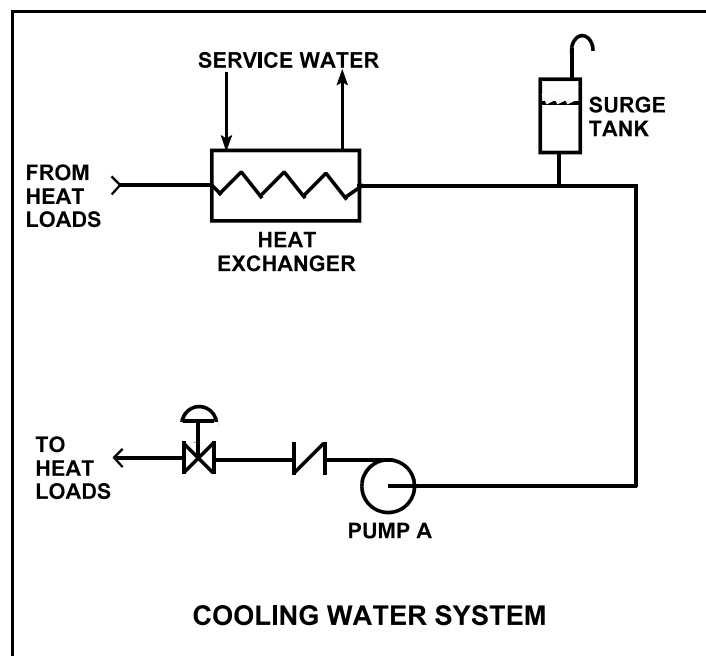

TOPIC: 291004
KNOWLEDGE: K1.07 [2.8/2.8]
QID: B922 (P1622)

An AC induction motor-driven centrifugal pump is circulating water at 180°F with a motor current of 100 amps. After several hours, system temperature has changed such that the water density has increased by 4 percent.

Assuming pump head and volumetric flow rate do not change, which one of the following is the new pump motor current?

- A. 84 amps
- B. 96 amps
- C. 104 amps
- D. 116 amps

ANSWER: C.

TOPIC: 291004
KNOWLEDGE: K1.07 [2.8/2.8]
QID: B1026

A motor-driven centrifugal pump exhibited indications of pump failure while being started. Which one of the following pairs of observations indicate that the pump failure is a sheared impeller shaft?

- A. Excessive duration of high starting current and motor breaker trips
- B. Excessive duration of high starting current and no change in system flow rate
- C. Lower than normal running current and motor breaker trips
- D. Lower than normal running current and no change in system flow rate

ANSWER: D.

TOPIC: 291004
KNOWLEDGE: K1.07 [2.8/2.8]
QID: B1726

A cooling water pump is being driven by an AC induction motor. Which one of the following describes how and why pump motor current will change if the pump shaft shears?

- A. Decreases due to decreased pump work
- B. Decreases due to decreased counter electromotive force
- C. Increases due to increased pump work
- D. Increases due to decreased counter electromotive force

ANSWER: A.

TOPIC: 291004
KNOWLEDGE: K1.07 [2.8/2.8]
QID: B2020 (P2023)

A reactor recirculation pump is circulating reactor coolant at 150°F. After several hours the reactor coolant temperature has increased to 200°F.

Assuming recirculation pump flow rate (gpm) is constant, recirculation pump motor amps will have _____ because _____.

- A. decreased; coolant density has decreased
- B. decreased; system head losses have increased
- C. increased; coolant density has increased
- D. increased; system head losses have decreased

ANSWER: A.

TOPIC: 291004
KNOWLEDGE: K1.07 [2.8/2.8]
QID: B2219 (P1420)

A centrifugal pump is circulating water at 150°F in a cooling water system. After several hours the water temperature has decreased to 100°F. Assuming system flow rate (gpm) is constant, pump motor amps will have _____ because _____ has increased.

- A. increased; water density
- B. increased; motor efficiency
- C. decreased; water density
- D. decreased; motor efficiency

ANSWER: A.

TOPIC: 291004
KNOWLEDGE: K1.07 [2.8/2.8]
QID: B2423 (P2124)

A centrifugal pump in a cooling water system is circulating water at 180°F with a motor current of 200 amps. After several hours, system temperature has changed such that the water density has increased by 3 percent.

Assuming pump head remains the same, which one of the following is the new pump motor current?

- A. 203 amps
- B. 206 amps
- C. 218 amps
- D. 236 amps

ANSWER: B.

TOPIC: 291004
KNOWLEDGE: K1.07 [2.8/2.8]
QID: B2520 (P2520)

A constant-speed centrifugal pump motor draws the most current when the pump is...

- A. at maximum rated flow conditions.
- B. operating at runout flow.
- C. accelerating to normal speed during start.
- D. at shutoff head with no recirculation flow.

ANSWER: C.

TOPIC: 291004
KNOWLEDGE: K1.07 [2.8/2.8]
QID: B2822 (P2821)

An AC motor-driven centrifugal pump was just started. During the start, motor current remained peaked for 6 seconds before decreasing to standard running current. Normally, the starting current peak lasts about 4 seconds.

Which one of the following could have caused the extended starting current peak?

- A. The pump shaft was seized and did not turn.
- B. The pump was initially rotating slowly in the reverse direction.
- C. The pump discharge check valve was stuck closed and did not open.
- D. The pump was initially air bound, and then primed itself after 6 seconds of operation.

ANSWER: B.

TOPIC: 291004
KNOWLEDGE: K1.07 [2.8/2.8]
QID: B2921 (P2925)

A centrifugal pump is circulating water at 180°F with a pump motor current of 200 amps. After several hours, system temperature has changed such that the water density has increased by 6 percent.

Assuming pump head and volumetric flow rate do not change, which one of the following is the new pump motor current?

- A. 203 amps
- B. 206 amps
- C. 212 amps
- D. 224 amps

ANSWER: C.

TOPIC: 291004
KNOWLEDGE: K1.07 [2.8/2.8]
QID: B3820 (P3822)

An AC motor-driven centrifugal water pump was just started. During the start, motor current remained peaked for 2 seconds, and then decreased and stabilized at about one-fifth the standard running current. Normally, the starting current peak lasts about 4 seconds.

Which one of the following could have caused the abnormal start indications above?

- A. The pump shaft was initially seized and the motor breaker opened.
- B. The pump was initially rotating slowly in the reverse direction.
- C. The pump was initially air bound, and then primed itself after 2 seconds of operation.
- D. The coupling between the motor and pump shafts was left unfastened after maintenance.

ANSWER: D.

TOPIC: 291004
KNOWLEDGE: K1.07 [2.8/2.8]
QID: B4811 (P4811)

A radial flow centrifugal cooling water pump is driven by an AC induction motor. The pump can supply cooling water to several heat loads, all of which are in parallel alignment. The following pump conditions initially exist:

Pump motor current: 100 amps
Pump flow rate: 400 gpm
Pump suction temperature: 70°F

Four hours later, the motor is drawing 95 amps. Which one of the following could be responsible for the observed decrease in motor amps?

- A. The temperature of the cooling water being pumped decreased to 60°F with no change in pump flow rate.
- B. The temperature of the cooling water being pumped increased to 80°F with no change in pump flow rate.
- C. Cooling water flow was established to an additional heat load with no change in the temperature of the cooling water being pumped.
- D. Cooling water flow was isolated from an out-of-service heat load with no change in the temperature of the cooling water being pumped.

ANSWER: D.

TOPIC: 291004
KNOWLEDGE: K1.07 [2.8/2.8]
QID: B6311 (P6310)

A radial flow centrifugal cooling water pump is driven by an AC induction motor. The pump can supply cooling water to several heat loads, all of which are in parallel alignment. The following pump conditions initially exist:

Pump motor current: 100 amps
Pump flow rate: 400 gpm
Pump suction temperature: 70°F

Four hours later, the motor is drawing 105 amps. Which one of the following could be responsible for the observed increase in motor current?

- A. The temperature of the cooling water being pumped decreased to 60°F with no change in pump flow rate.
- B. The temperature of the cooling water being pumped increased to 80°F with no change in pump flow rate.
- C. Cooling water flow was established to an additional heat load with no change in the temperature of the cooling water being pumped.
- D. Cooling water flow was isolated from an out-of-service heat load with no change in the temperature of the cooling water being pumped.

ANSWER: C.

TOPIC: 291004
KNOWLEDGE: K1.08 [2.8/2.8]
QID: B519

Many large centrifugal pumps are interlocked so that the pump will not start unless its discharge valve is at least 90 percent closed. This interlock is provided to minimize the...

- A. duration of the pump motor starting current.
- B. required net positive suction head.
- C. loading on the pump thrust bearing.
- D. pump discharge pressure.

ANSWER: A.

TOPIC: 291004
KNOWLEDGE: K1.08 [2.8/2.8]
QID: B619

Which one of the following pumps should be started with its discharge valve throttled?

- A. Centrifugal
- B. Gear
- C. Reciprocating
- D. Screw

ANSWER: A.

TOPIC: 291004
KNOWLEDGE: K1.08 [2.8/2.8]
QID: B821 (P2622)

Which one of the following contains two reasons for starting a typical radial-flow centrifugal pump with the discharge piping full of water and the discharge valve shut?

- A. Prevent pump runout and prevent motor overspeed.
- B. Prevent pump runout and ensure lubrication of pump seals.
- C. Prevent water hammer and ensure adequate pump recirculation flow.
- D. Prevent water hammer and prevent excessive duration of starting current.

ANSWER: D.

TOPIC: 291004
KNOWLEDGE: K1.08 [2.8/2.8]
QID: B1822 (P1325)

Some large centrifugal pumps are interlocked so that the pump will not start unless its discharge valve is at least 90 percent closed. This interlock is provided to minimize...

- A. pump discharge pressure.
- B. heating of the pumped fluid.
- C. the potential for cavitation at the pump suction.
- D. the duration of the pump motor starting current.

ANSWER: D.

TOPIC: 291004
KNOWLEDGE: K1.08 [2.8/2.8]
QID: B2120 (P624)

Which one of the following specifies the proper pump discharge valve position and the basis for that position when starting a large centrifugal pump?

- A. Discharge valve fully open to reduce duration of motor starting current
- B. Discharge valve throttled to reduce duration of motor starting current
- C. Discharge valve fully open to ensure adequate pump net positive suction head
- D. Discharge valve throttled to ensure adequate pump net positive suction head

ANSWER: B.

TOPIC: 291004
KNOWLEDGE: K1.11 [2.4/2.5]
QID: B520 (P2322)

A centrifugal fire water pump takes a suction on an open storage tank and discharges through a fire hose. Which one of the following will cause the pump to operate at shutoff head?

- A. The fire hose nozzle is raised to an elevation that prevents any flow.
- B. Suction temperature is increased to the point that gas binding occurs.
- C. Pump speed is adjusted to the value at which cavitation occurs.
- D. Suction pressure is adjusted until available net positive suction head is reduced to zero feet.

ANSWER: A.

TOPIC: 291004
KNOWLEDGE: K1.11 [2.4/2.5]
QID: B1823 (P109)

When a centrifugal pump is operating at shutoff head, it is pumping at _____ capacity and _____ discharge head.

- A. maximum; maximum
- B. maximum; minimum
- C. minimum; maximum
- D. minimum; minimum

ANSWER: C.

TOPIC: 291004
KNOWLEDGE: K1.11 [2.4/2.5]
QID: B2018 (P2022)

A variable-speed centrifugal fire water pump is taking a suction on an open storage tank and discharging through a 4-inch diameter fire hose and through a nozzle located 50 feet above the pump.

Which one of the following will cause the pump to operate at shutoff head?

- A. The fire hose is replaced with a 6-inch diameter fire hose.
- B. The fire hose is replaced with a 2-inch diameter fire hose.
- C. Pump speed is increased until steam formation at the eye of the pump prevents pump flow.
- D. Pump speed is decreased until pump discharge pressure is insufficient to cause flow.

ANSWER: D.

TOPIC: 291004
KNOWLEDGE: K1.11 [2.4/2.5]
QID: B2121 (P1523)

Which one of the following describes centrifugal pump operating parameters at shutoff head?

- A. High discharge pressure, low flow, low power demand
- B. High discharge pressure, high flow, low power demand
- C. Low discharge pressure, low flow, high power demand
- D. Low discharge pressure, high flow, high power demand

ANSWER: A.

TOPIC: 291004
KNOWLEDGE: K1.11 [2.4/2.5]
QID: B2721 (P2721)

A centrifugal fire water pump takes a suction on an open storage tank and discharges through a fire hose. Which one of the following will cause the pump to operate at shutoff head?

- A. A firefighter inadvertently severs the fire hose.
- B. The fire hose becomes completely crimped in a fire door.
- C. Fire water storage tank level drops below the pump suction tap.
- D. A firefighter adjusts the fire hose nozzle spray pattern from “deluge” to “fog.”

ANSWER: B.

TOPIC: 291004
KNOWLEDGE: K1.11 [2.4/2.5]
QID: B3320 (P2820)

A centrifugal fire water pump takes a suction on an open storage tank and discharges through a fire hose. Which one of the following will cause the pump to operate at shutoff head?

- A. A firefighter inadvertently severs the fire hose.
- B. The fire hose becomes partially crimped in a fire door.
- C. Fire water storage tank level drops below the pump suction tap.
- D. A firefighter adjusts the fire hose nozzle spray pattern from “deluge” to “off”.

ANSWER: D.

TOPIC: 291004
KNOWLEDGE: K1.12 [2.8/2.8]
QID: B23

Which one of the following will occur if a motor-driven centrifugal pump is operated continuously at runout conditions?

- A. Pump failure due to excessive pump cavitation
- B. Pump failure due to overheating caused by the increased impeller-to-casing friction
- C. Motor failure due to excessive current being drawn through the motor windings
- D. Motor failure due to overheating caused by increased windage losses

ANSWER: C.

TOPIC: 291004
KNOWLEDGE: K1.12 [2.8/2.8]
QID: B321

A centrifugal pump is operating at rated conditions in an open system. If a system transient results in the pump operating at runout, which one of the following indications will be present?

- A. Increased discharge pressure
- B. Decreased pump motor current
- C. Increased pump vibration
- D. Decreased pump flow rate

ANSWER: C.

TOPIC: 291004
KNOWLEDGE: K1.12 [2.8/2.8]
QID: B424

Operating a motor-driven centrifugal pump under "pump runout" conditions causes...

- A. pump overheating, cavitation, and ultimately pump failure.
- B. excessive motor current to be drawn, damage to the motor windings, and ultimately motor failure.
- C. excessive motor current to be drawn, overheating of pump and motor bearings, and ultimately pump failure.
- D. no damage, because most pumps and motors are designed to operate without failure under pump runout conditions.

ANSWER: B.

TOPIC: 291004
KNOWLEDGE: K1.12 [2.8/2.8]
QID: B1024 (P1721)

Refer to the drawing of centrifugal pump and system operating curves (see figure below).

Which point represents pump operation at runout conditions?

- A. Point A
- B. Point B
- C. Point C
- D. Point D

ANSWER: C.

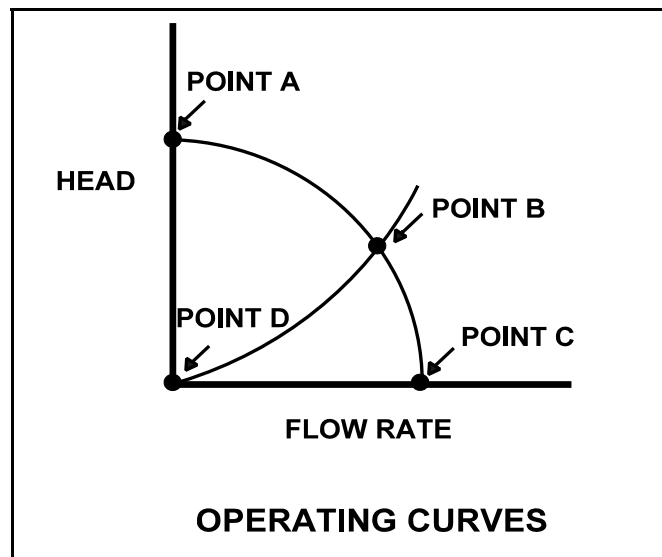

TOPIC: 291004
KNOWLEDGE: K1.12 [2.8/2.8]
QID: B1323 (P1623)

A centrifugal pump is operating at its maximum design flow rate, delivering water through two parallel valves. Valve "A" is half open, and valve "B" is one quarter open.

Which one of the following will occur if both valves are fully opened?

- A. The pump will operate at shutoff head.
- B. The pump available net positive suction head will increase.
- C. The pump required net positive suction head will decrease.
- D. The pump will operate at runout conditions.

ANSWER: D.

TOPIC: 291004
KNOWLEDGE: K1.12 [2.8/2.8]
QID: B1425

What adverse effect is caused by operating a motor-driven centrifugal pump under runout conditions?

- A. Pump failure due to overspeed of the pump impeller
- B. Pump failure due to excessive pump cavitation
- C. Motor failure due to excessive motor winding current
- D. Motor failure due to loss of cooling from pumped fluid

ANSWER: C.

TOPIC: 291004
KNOWLEDGE: K1.12 [2.8/2.8]
QID: B1920 (P1123)

Which one of the following describes typical radial-flow centrifugal pump runout conditions?

- A. High discharge pressure, low flow, high power demand
- B. High discharge pressure, high flow, low power demand
- C. Low discharge pressure, low flow, low power demand
- D. Low discharge pressure, high flow, high power demand

ANSWER: D.

TOPIC: 291004
KNOWLEDGE: K1.12 [2.8/2.8]
QID: B3910 (P3910)

Refer to the drawing of a cooling water system in which only centrifugal pump A is operating and the common pump discharge valve is currently 90 percent open (see figure below).

An abnormal total heat load on the cooling water system is causing pump A to approach operation at runout conditions. Which one of the following will cause pump A to operate farther away from runout conditions? (Assume that satisfactory available net positive suction head is maintained at all times.)

- A. Starting pump B.
- B. Positioning the discharge valve to 100 percent open.
- C. Raising the water level in the surge tank by 2 feet.
- D. Decreasing heat exchanger service water flow rate by 10 percent.

ANSWER: A.

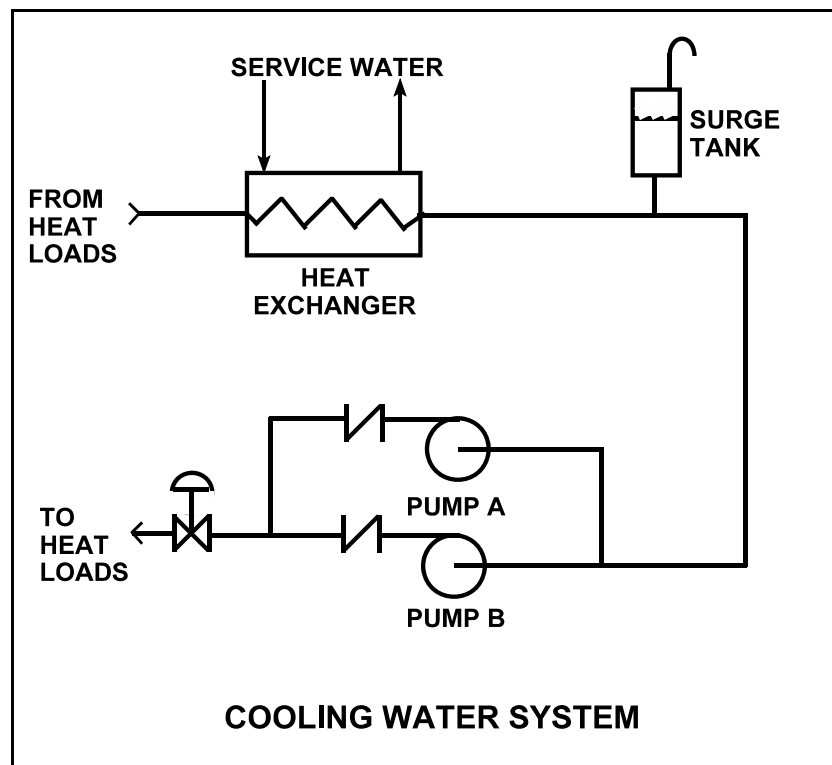

TOPIC: 291004
KNOWLEDGE: K1.12 [2.8/2.8]
QID: B5111 (P5111)

A flow-limiting venturi in the discharge piping of a centrifugal pump decreases the potential for the pump to experience...

- A. runout
- B. reverse flow
- C. shutoff head
- D. water hammer

ANSWER: A.

TOPIC: 291004
KNOWLEDGE: K1.13 [2.6/2.7]
QID: B325

Refer to the drawing of a cooling water system and the associated pump/system operating curves (see figure below).

Pumps A and B are identical single-speed centrifugal pumps and only pump A is operating. If pump B is started, system flow rate will be _____ and common pump discharge pressure will be _____.

- A. the same; higher
- B. higher; the same
- C. the same; the same
- D. higher; higher

ANSWER: D.

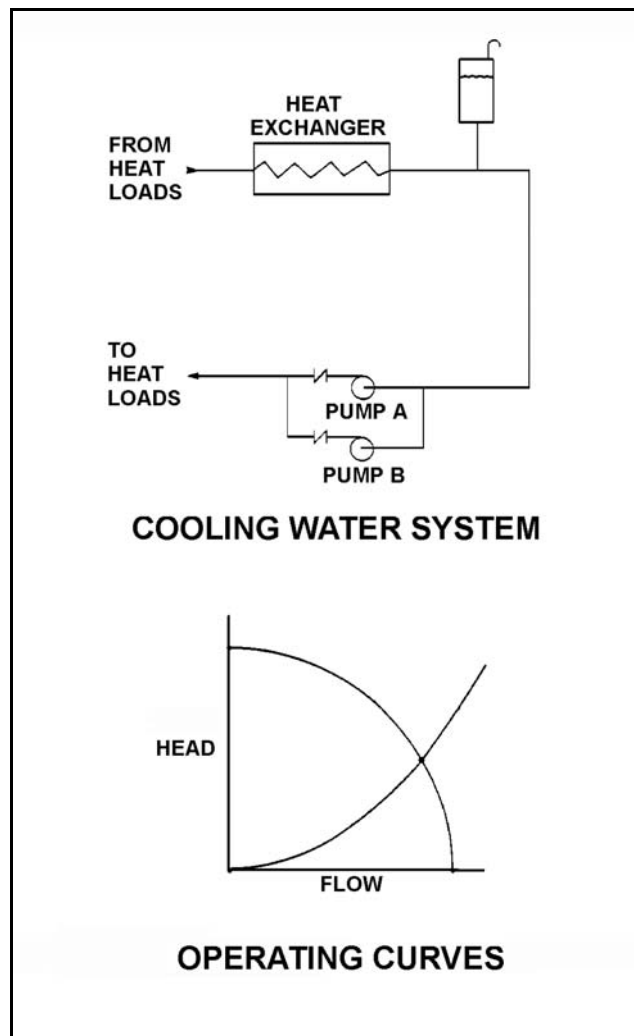

TOPIC: 291004
KNOWLEDGE: K1.13 [2.6/2.7]
QID: B521 (P2224)

A motor-driven centrifugal pump is operating in an open system with its discharge valve throttled to 50 percent. How will the pump be affected if the discharge valve is fully opened?

- A. Total developed head decreases, and motor current decreases.
- B. Total developed head increases, and available net positive suction head decreases.
- C. The potential for pump cavitation decreases, and pump differential pressure decreases.
- D. Available net positive suction head decreases, and pump differential pressure decreases.

ANSWER: D.

TOPIC: 291004
KNOWLEDGE: K1.13 [2.6/2.7]
QID: B622

A typical radial-flow centrifugal pump is operating at rated conditions in an open system with all valves fully open. If the pump discharge valve is throttled to 50 percent closed, pump discharge pressure will _____ and pump motor current will _____.

- A. decrease; decrease
- B. decrease; increase
- C. increase; increase
- D. increase; decrease

ANSWER: D.

TOPIC: 291004
 KNOWLEDGE: K1.13 [2.6/2.7]
 QID: B722 (P723)

Refer to the drawing of a lube oil temperature control system and the associated pump/system operating curves (see figure below).

The pump is operating at point B on the operating curve. If the temperature control valve modulates farther closed, operating point B will be located on curve _____, closer to point _____.
 (The options below assume that curves 1 and 2 are exactly as shown in the figure.)

- A. 1; D
- B. 2; A
- C. 1; E
- D. 2; C

ANSWER: B.

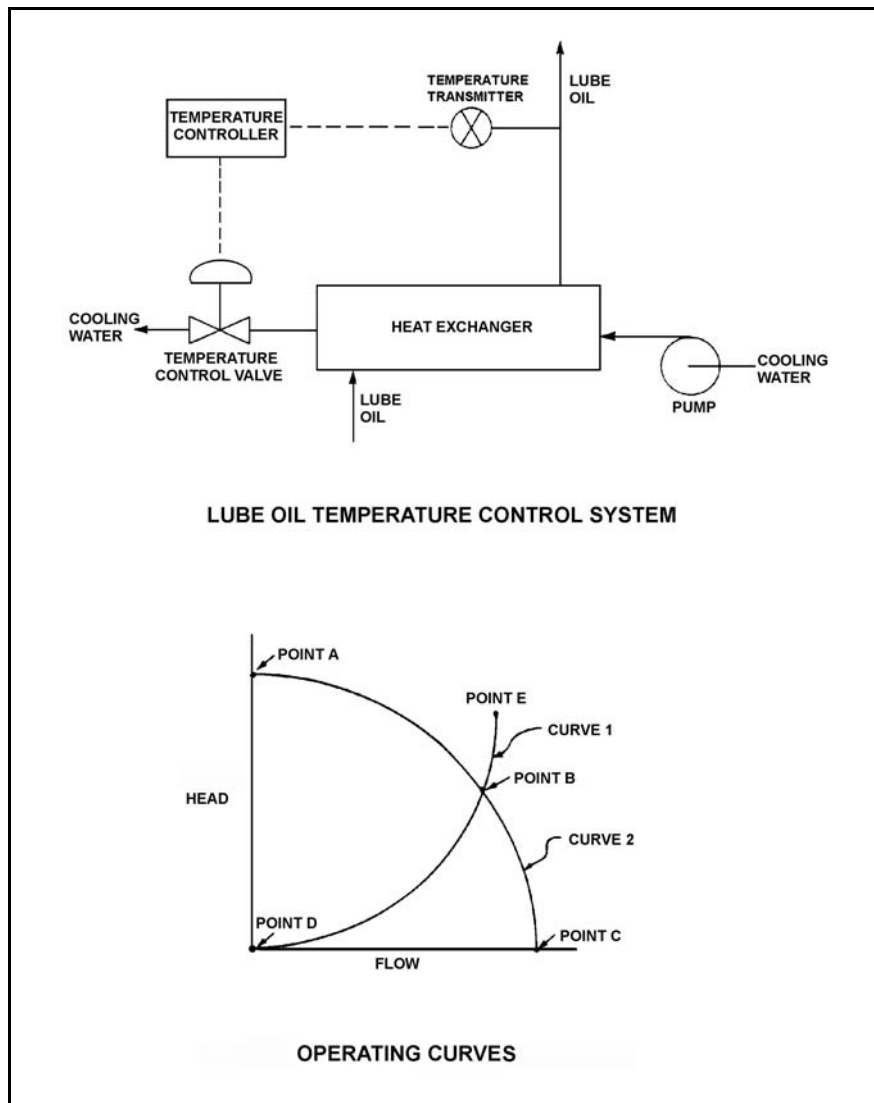

TOPIC: 291004
KNOWLEDGE: K1.13 [2.6/2.7]
QID: B823

Which one of the following actions will correct a cavitating centrifugal pump?

- A. Increasing the pump speed
- B. Lowering the pump suction pressure
- C. Lowering the pump suction temperature
- D. Cycling the pump off and on a few times

ANSWER: C.

TOPIC: 291004
KNOWLEDGE: K1.13 [2.6/2.7]
QID: B1122

A centrifugal pump is operating at rated conditions in an open system. If the pump discharge valve is fully closed, pump discharge pressure will _____ and motor current will _____.

- A. increase; decrease
- B. decrease; decrease
- C. increase; increase
- D. decrease; increase

ANSWER: A.

TOPIC: 291004
 KNOWLEDGE: K1.13 [2.6/2.7]
 QID: B1423 (P623)

Refer to the drawing of a lube oil temperature control system and the associated pump/system operating curves (see figure below).

The pump is initially operating at point B. If the temperature control valve modulates farther open, operating point B will be located on curve _____, closer to point _____. (The options below refer to curves 1 and 2 exactly as shown in the figure.)

- A. 1; D
- B. 2; A
- C. 1; E
- D. 2; C

ANSWER: D.

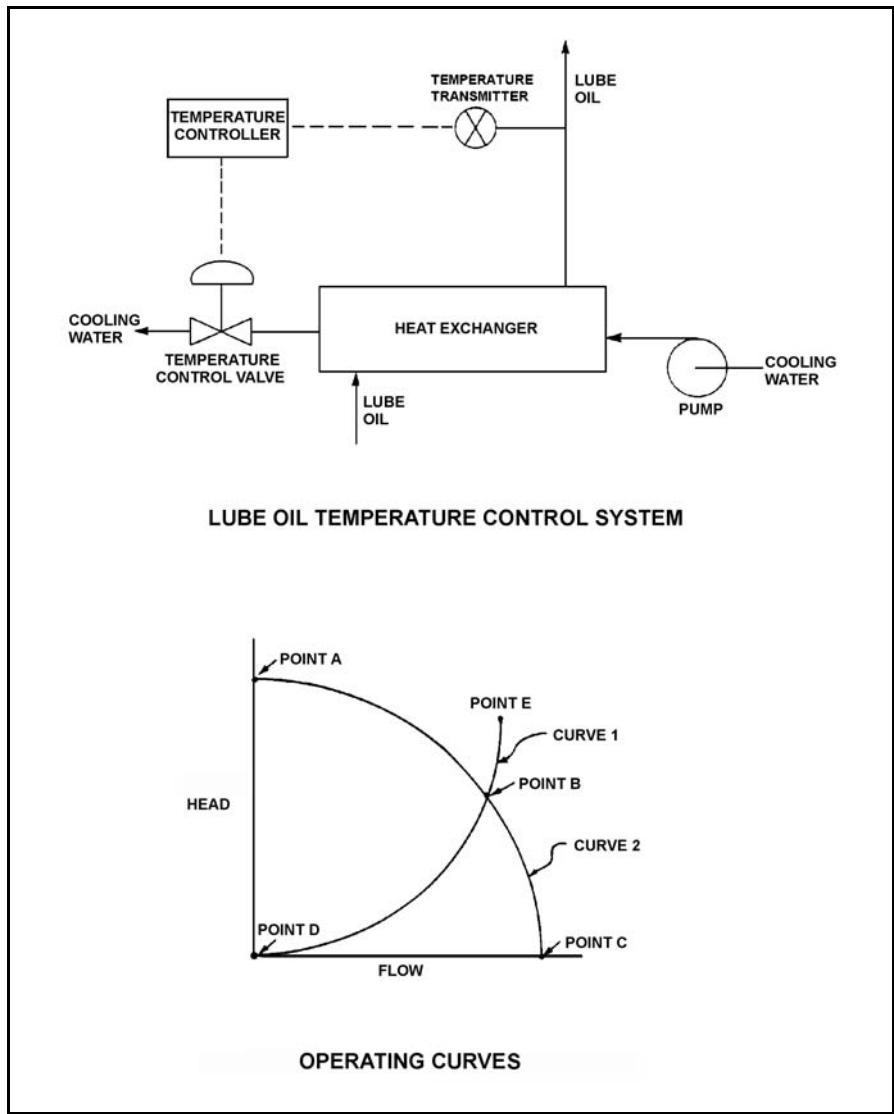

TOPIC: 291004
KNOWLEDGE: K1.13 [2.6/2.7]
QID: B1522

Which one of the following components of a centrifugal pump has the specific primary function of increasing the kinetic energy of a fluid?

- A. Volute
- B. Impeller
- C. Diffuser
- D. Discharge nozzle

ANSWER: B.

TOPIC: 291004
KNOWLEDGE: K1.13 [2.6/2.7]
QID: B1722 (P1725)

A typical single-stage radial-flow centrifugal pump is being returned to service following maintenance on its three-phase AC induction motor. Which one of the following will occur when the pump is started if two of the three motor power leads were inadvertently swapped during restoration?

- A. The motor breaker will trip on instantaneous overcurrent.
- B. The motor will not turn and will emit a humming sound.
- C. The pump will rotate in the reverse direction with reduced or no flow rate.
- D. The pump will rotate in the normal direction with reduced flow rate.

ANSWER: C.

TOPIC: 291004
KNOWLEDGE: K1.13 [2.6/2.7]
QID: B2323 (P2325)

Refer to the drawing of centrifugal pump and system operating curves (see figure below).

A centrifugal pump is initially operating at point B. If the pump speed is reduced by one-half, the new operating point will be located on curve _____, closer to point _____. (Assume that no other changes occur in the system.)

- A. 1; D
- B. 2; A
- C. 1; E
- D. 2; C

ANSWER: A.

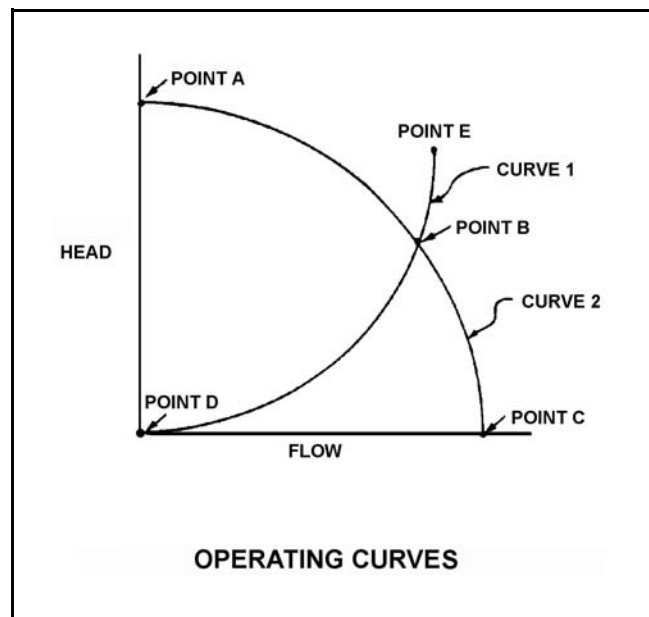

TOPIC: 291004
KNOWLEDGE: K1.13 [2.6/2.7]
QID: B2422 (P2422)

Refer to the drawing of a lube oil temperature control system (see figure below).

The pump is operating with the temperature control valve one-half open. If the temperature control valve modulates farther closed, system head loss will _____ and pump head will _____.

- A. increase, decrease
- B. increase, increase
- C. decrease, decrease
- D. decrease, increase

ANSWER: B.

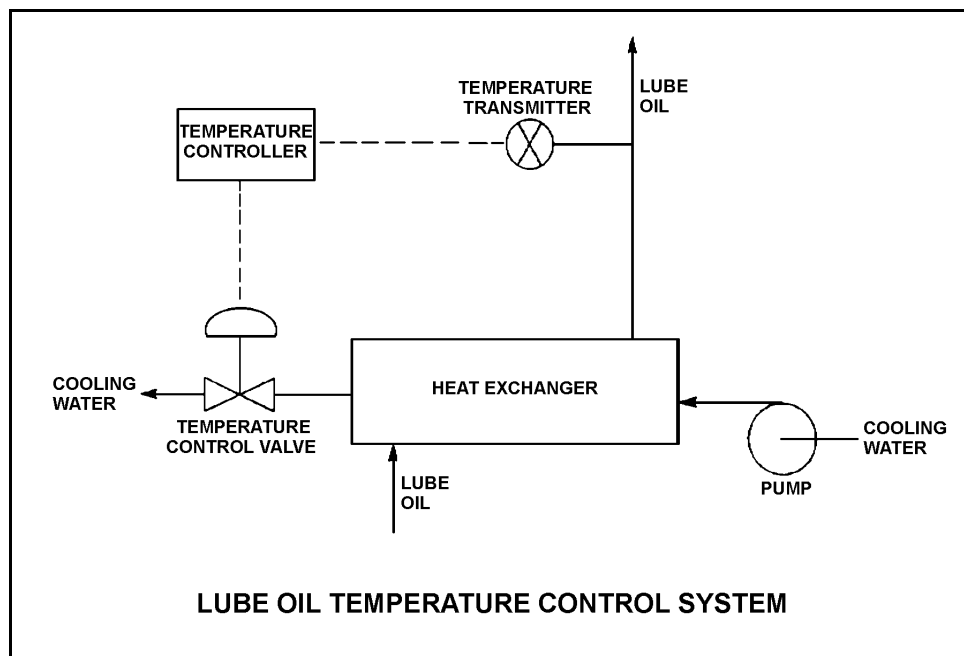

TOPIC: 291004
KNOWLEDGE: K1.13 [2.6/2.7]
QID: B2524 (P2523)

Refer to the drawing of a lube oil temperature control system and the associated pump/system operating curves (see figure below).

If the pump is initially operating at point B, how will the operating point change if the temperature controller setpoint is decreased by 10°F ?

- A. Operating point B will be located on curve 1 closer to point E.
- B. Operating point B will be located on curve 1 closer to point D.
- C. Operating point B will be located on curve 2 closer to point A.
- D. Operating point B will be located on curve 2 closer to point C.

ANSWER: D.

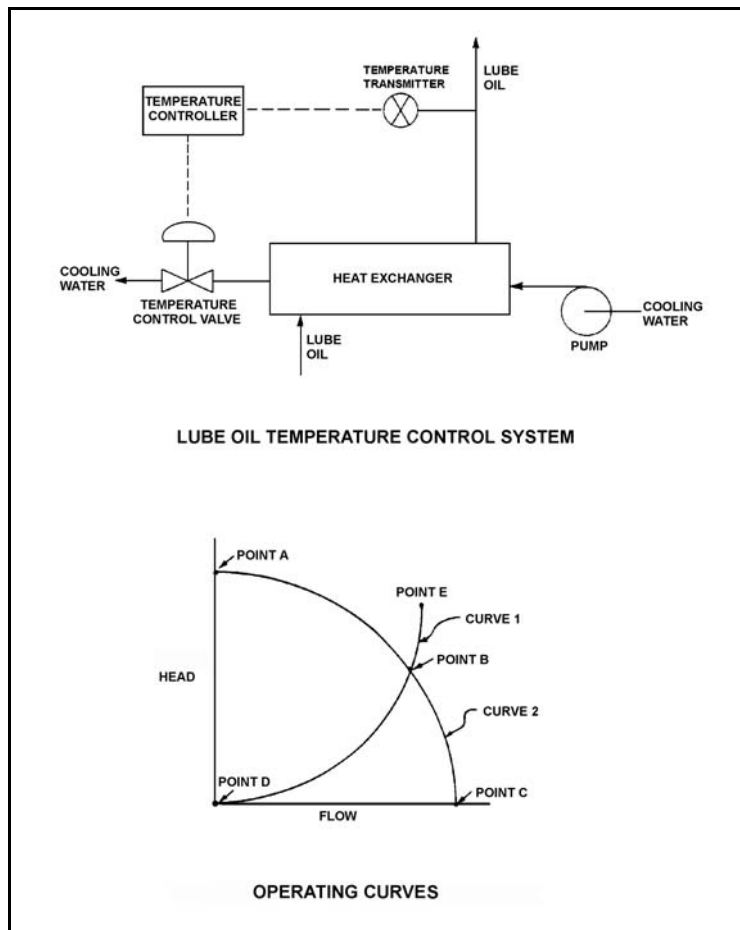

TOPIC: 291004
KNOWLEDGE: K1.13 [2.6/2.7]
QID: B2622 (P2624)

Which one of the following describes a reason for designing centrifugal pumps with suction nozzles that are larger than their discharge nozzles?

- A. Increases total pump head by increasing the velocity head at the suction of the pump.
- B. Increases the differential pressure across the pump by decreasing pump head loss.
- C. Increases pump available net positive suction head by decreasing head loss at the pump suction.
- D. Increases pump capacity by decreasing turbulence at the suction of the pump.

ANSWER: C.

TOPIC: 291004
KNOWLEDGE: K1.13 [2.6/2.7]
QID: B2623

Refer to the drawing of a cooling water system and the associated pump/system operating curves (see figure below).

Pumps A and B are identical single-speed centrifugal pumps and both pumps are operating. If pump B trips, after the system stabilizes, system flow rate will be...

- A. more than one-half the original flow.
- B. one-half the original flow.
- C. less than one-half the original flow.
- D. the same; only the pump head will change.

ANSWER: A.

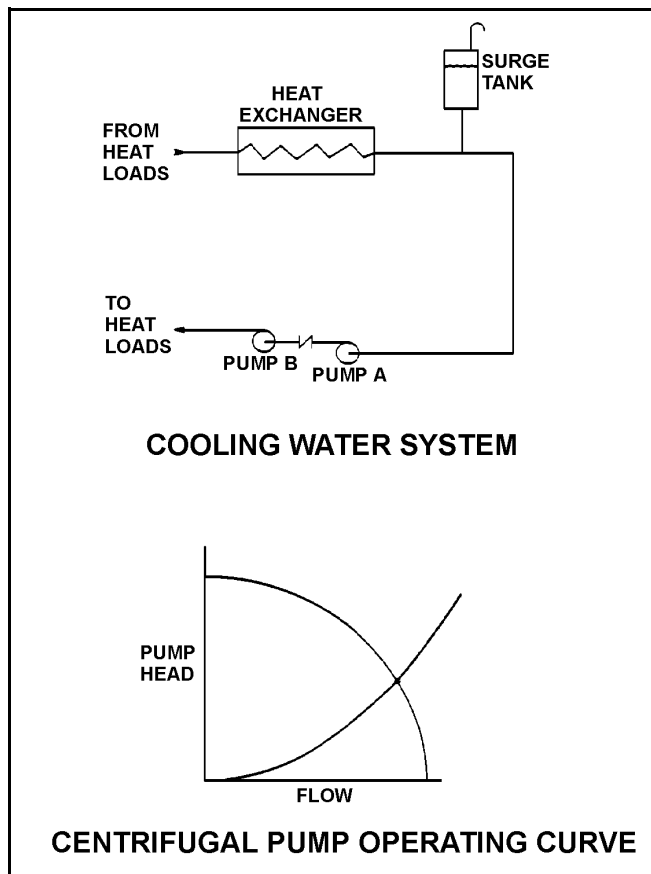

TOPIC: 291004
KNOWLEDGE: K1.13 [2.6/2.7]
QID: B3022 (P3020)

A centrifugal pump is needed to take suction on a water storage tank and deliver high pressure water to a water spray system. To minimize axial thrust on the pump shaft, the pump should have _____ stage(s); and to maximize the available NPSH at the impeller inlet, the pump should have a _____ suction impeller.

- A. a single; single
- B. a single; double
- C. multiple opposed; single
- D. multiple opposed; double

ANSWER: D.

TOPIC: 291004
KNOWLEDGE: K1.13 [2.6/2.7]
QID: B3522

A single-speed centrifugal pump is needed to supply river water to a storage facility. The pump must be capable of providing a very high flow rate at a low discharge pressure. Which one of the following types of centrifugal pumps is best suited for this application?

- A. Single-stage, axial flow
- B. Single-stage, radial flow
- C. Multiple-stage, axial flow
- D. Multiple-stage, radial flow

ANSWER: A.

TOPIC: 291004
KNOWLEDGE: K1.13 [2.6/2.7]
QID: B5812 (P5813)

Centrifugal pumps A and B are identical except that pump A uses a single-suction impeller while pump B uses a double-suction impeller. If both pumps are pumping water at the same inlet temperature, inlet pressure, and flow rate, single-suction pump A typically will have the _____ impeller axial thrust and the _____ required net positive suction head.

- A. greater; greater
- B. greater; smaller
- C. smaller; greater
- D. smaller; smaller

ANSWER: A.

TOPIC: 291004
KNOWLEDGE: K1.13 [2.6/2.7]
QID: B6012

A single-stage (single impeller) centrifugal pump and a two-stage (two impellers) centrifugal pump have identical head-capacity curves. The pumps are connected to identical suction and discharge piping in a water system.

Compared to the single-stage pump, the two-stage pump produces the same flow rate at about _____ pump discharge head; and for the same flow rate, the two-stage pump requires _____ net positive suction head.

- A. twice the; less
- B. twice the; more
- C. the same; less
- D. the same; more

ANSWER: C.

TOPIC: 291004
KNOWLEDGE: K1.13 [2.6/2.7]
QID: B6712 (P6711)

A centrifugal pump is located adjacent to the bottom of an open water storage tank. The pump is taking suction from a river and discharging to the bottom of the tank. Initially the tank was empty and the pump was operating at point B on the drawing below.

When tank water level reaches 30 feet, the new pump operating point will be located on curve _____, closer to point _____ . (Assume that no other changes occur in the system.)

- A. 1; D
- B. 2; A
- C. 1; E
- D. 2; C

ANSWER: B.

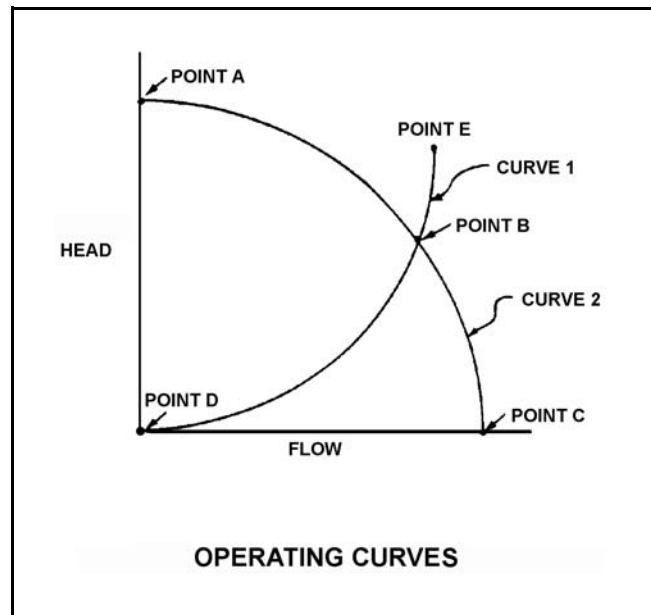

TOPIC: 291004
KNOWLEDGE: K1.14 [2.5/2.5]
QID: B24

A single-speed centrifugal fire pump takes suction on a water storage tank and discharges through a flexible fire hose. Which one of the following describes the response of the pump discharge flow rate?

- A. Decreases as the level in the storage tank decreases
- B. Increases as the height of the fire hose nozzle is increased
- C. Remains constant as the level in the storage tank decreases
- D. Remains constant as the height of the fire hose nozzle is increased

ANSWER: A.

TOPIC: 291004
KNOWLEDGE: K1.14 [2.5/2.5]
QID: B623

A centrifugal pump is operating at rated conditions in an open system with all valves fully open. If the pump suction valve is throttled to 50 percent closed, pump suction pressure will _____ and pump flow rate will _____.

- A. increase; decrease
- B. decrease; remain the same
- C. increase; remain the same
- D. decrease; decrease

ANSWER: D.

TOPIC: 291004
KNOWLEDGE: K1.14 [2.5/2.5]
QID: B723 (P724)

A centrifugal pump is operating normally in an open system. If the pump recirculation valve is opened farther, pump discharge pressure will _____ and pump flow rate will _____.

- A. increase; decrease
- B. decrease; increase
- C. increase; increase
- D. decrease; decrease

ANSWER: B.

TOPIC: 291004
KNOWLEDGE: K1.14 [2.5/2.5]
QID: B1123 (P826)

If the fully-open discharge valve of a reciprocating positive displacement pump is throttled closed approximately 10 percent, pump flow rate will _____ and pump head will _____.
(Assume "ideal" pump response.)

- A. decrease; increase
- B. remain constant; increase
- C. decrease; remain constant
- D. remain constant; remain constant

ANSWER: B.

TOPIC: 291004
KNOWLEDGE: K1.14 [2.5/2.5]
QID: B1421 (P1421)

A centrifugal pump is operating normally in an open system with all valves fully open. If the pump discharge valve is throttled to 50 percent, pump suction pressure will _____ and pump discharge pressure will _____.

- A. increase; decrease
- B. decrease; increase
- C. increase; increase
- D. decrease; decrease

ANSWER: C.

TOPIC: 291004
KNOWLEDGE: K1.14 [2.5/2.5]
QID: B2722 (P2722)

A centrifugal pump is operating at maximum design flow rate, taking suction on a vented water storage tank and discharging through two parallel valves. Valve "A" is fully open and valve "B" is half open.

Which one of the following will occur if valve B is fully closed?

- A. The pump will operate at shutoff head.
- B. The pump will operate at runout conditions.
- C. The pump available net positive suction head will increase.
- D. The pump required net positive suction head will increase.

ANSWER: C.

TOPIC: 291004
KNOWLEDGE: K1.14 [2.5/2.5]
QID: B2825 (P2224)

A motor-driven centrifugal pump is operating in an open system with its discharge valve throttled to 50 percent. How will the pump be affected if the discharge valve is fully opened?

- A. Motor current decreases and total developed head decreases.
- B. Available net positive suction head (NPSH) decreases, and pump differential pressure decreases.
- C. Total developed head increases and available NPSH decreases.
- D. The potential for pump cavitation decreases, and pump differential pressure decreases.

ANSWER: B.

TOPIC: 291004
KNOWLEDGE: K1.14 [2.5/2.5]
QID: B3623 (P3623)

A centrifugal firewater pump is operating to pressurize a fire main. The pump takes suction on a water reservoir. The reservoir water level and the eye of the pump impeller are both at sea level.

Given:

- The pump has a design shutoff head of 100 feet.
- The required net positive suction head (NPSH) for the pump is 15 feet.
- The reservoir water temperature is 60°F.
- A fire hose connected to the fire main is being used to suppress an elevated fire.

At which one of the following elevations (referenced to sea level) will the fire hose spray nozzle first be unable to provide flow? (Disregard head loss in the fire main and fire hose.)

- A. 86 feet
- B. 101 feet
- C. 116 feet
- D. 135 feet

ANSWER: B.

TOPIC: 291004
KNOWLEDGE: K1.14 [2.5/2.5]
QID: B3911 (P3912)

A centrifugal firewater pump is operating to pressurize a fire main. The pump takes suction from a water reservoir. A fire hose connected to the fire main is being used to suppress an elevated fire.

Given:

- The eye of the pump impeller is located 5 feet above the reservoir water level.
- The pump has a design shutoff head of 120 feet.
- The required net positive suction head (NPSH) for the pump is 15 feet.
- The reservoir water temperature is 60°F.

At which one of the following elevations above the eye of the pump impeller will the fire hose spray nozzle first be unable to provide flow? (Disregard all sources of head loss.)

- A. 111 feet
- B. 116 feet
- C. 121 feet
- D. 126 feet

ANSWER: B.

TOPIC: 291004
KNOWLEDGE: K1.14 [2.5/2.5]
QID: B4312 (P4313)

A centrifugal firewater pump is operating to pressurize a fire main. The pump takes suction from a vented water storage tank. A fire hose connected to the fire main is being used to suppress an elevated fire.

Given:

- The eye of the pump impeller is located 30 feet below the tank water level.
- The pump has a design shutoff head of 120 feet.
- The required net positive suction head (NPSH) for the pump is 15 feet.
- The tank water temperature is 60°F.

At which one of the following elevations above the eye of the pump impeller will the fire hose spray nozzle first be unable to provide flow? (Disregard all sources of head loss.)

- A. 106 feet
- B. 121 feet
- C. 136 feet
- D. 151 feet

ANSWER: D.

TOPIC: 291004
KNOWLEDGE: K1.14 [2.5/2.5]
QID: B4513 (P1423)

Which one of the following is at a relatively high value when a centrifugal pump is operating at shutoff head?

- A. Pump motor current
- B. Pump volumetric flow rate
- C. Available net positive suction head
- D. Required net positive suction head

ANSWER: C.

TOPIC: 291004
KNOWLEDGE: K1.14 [2.5/2.5]
QID: B4911 (P4912)

A centrifugal firewater pump is operating to pressurize a fire main. The pump takes suction from a water reservoir. A fire hose connected to the fire main is being used to suppress an elevated fire.

Given:

- The eye of the pump impeller is located 15 feet below the reservoir water level.
- The pump has a design shutoff head of 120 feet.
- The required net positive suction head (NPSH) for the pump is 15 feet.
- The reservoir water temperature is 60°F.

At which one of the following elevations above the reservoir water level will the fire hose spray nozzle first be unable to provide flow? (Disregard all sources of head loss.)

- A. 91 feet
- B. 106 feet
- C. 121 feet
- D. 136 feet

ANSWER: C.

TOPIC: 291004
KNOWLEDGE: K1.14 [2.5/2.5]
QID: B5412 (P5412)

A motor-driven centrifugal pump is operating in a closed-loop cooling water system and is unable to achieve its rated volumetric flow rate due to cavitation. Which one of the following will enable the pump to achieve a higher volumetric flow rate before cavitation occurs?

- A. Operate the system at a higher pressure.
- B. Operate the system at a higher temperature.
- C. Remove the existing pump motor and install a motor with a higher horsepower rating.
- D. Remove the existing pump and install a same-capacity pump with a higher minimum required net positive suction head rating.

ANSWER: A.

TOPIC: 291004
KNOWLEDGE: K1.14 [2.5/2.5]
QID: B5712 (P5712)

Refer to the graph that represents the head-capacity characteristics for a single-speed centrifugal cooling water pump (see figure below).

Which one of the following lists a pair of parameters that could be represented by curves A and B?
(Note: NPSH = net positive suction head.)

- | | <u>Curve A</u> | <u>Curve B</u> |
|----|------------------|------------------|
| A. | Pump Head | Available NPSH |
| B. | Available NPSH | Required NPSH |
| C. | Required NPSH | System Head Loss |
| D. | System Head Loss | Pump Head |

ANSWER: B.

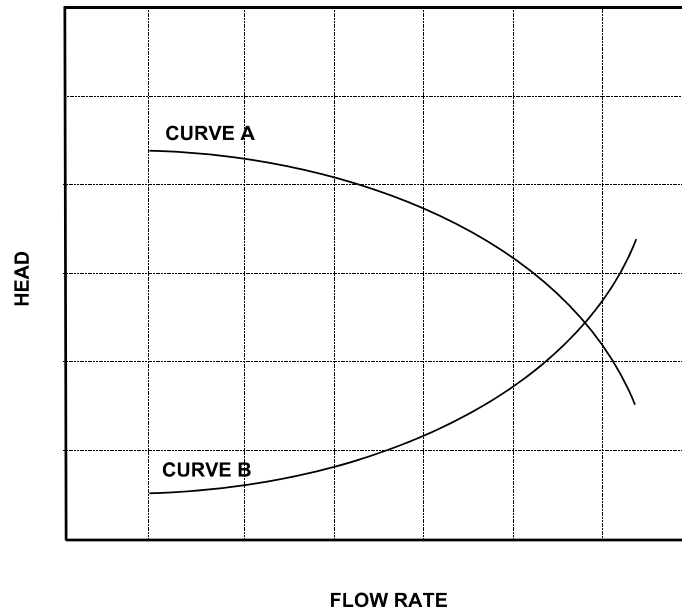

TOPIC: 291004
KNOWLEDGE: K1.14 [2.5/2.5]
QID: B6511 (P6512)

A motor-driven centrifugal pump is operating normally in a closed loop cooling water system. When the pump discharge flow control valve is opened further, the pump is unable to provide the desired volumetric flow rate due to cavitation. Which one of the following will enable a higher pump volumetric flow rate before cavitation occurs?

- A. Remove the existing motor and install a motor with a lower horsepower rating.
- B. Remove the existing motor and install a motor with a higher horsepower rating.
- C. Remove the existing pump and install a same-capacity pump with a lower minimum net positive suction head requirement.
- D. Remove the existing pump and install a same-capacity pump with a higher minimum net positive suction head requirement.

ANSWER: C.

TOPIC: 291004
KNOWLEDGE: K1.15 [2.9/2.9]
QID: B624

A centrifugal pump is susceptible to overheating and possible cavitation while operating with its discharge valve closed, unless...

- A. the pump is steam driven.
- B. the suction valve is also closed.
- C. pump seal cooling is provided.
- D. minimum flow protection is provided.

ANSWER: D.

TOPIC: 291004
KNOWLEDGE: K1.15 [2.9/2.9]
QID: B1623

Which one of the following describes the typical purpose of minimum flow piping for a centrifugal pump?

- A. Prevent pump runout during high flow conditions.
- B. Prevent vortexing at the pump suction during high flow conditions.
- C. Ensure adequate net positive suction head during low flow conditions.
- D. Ensure adequate pump cooling during low flow conditions.

ANSWER: D.

TOPIC: 291004
KNOWLEDGE: K1.16 [2.5/2.7]
QID: B323 (P326)

A positive displacement pump (PDP) is operating in an open system. PDP parameters are as follows:

PDP speed	= 1,000 rpm
PDP discharge pressure	= 2,000 psig
PDP suction pressure	= 50 psig
PDP flow rate	= 150 gpm

Which one of the following changes will cause PDP flow rate to exceed 200 gpm?

- A. A second identical discharge path is opened.
- B. PDP speed is increased to 1,500 rpm.
- C. PDP suction pressure is increased to 120 psig.
- D. Downstream system pressure is decreased to 1,000 psig.

ANSWER: B.

TOPIC: 291004
KNOWLEDGE: K1.16 [2.5/2.7]
QID: B824

The volumetric flow rate of a positive displacement pump is directly proportional to the:

- A. fluid density.
- B. motor horsepower.
- C. slip ratio.
- D. pump speed.

ANSWER: D.

TOPIC: 291004
KNOWLEDGE: K1.16 [2.5/2.7]
QID: B1021 (P2223)

A centrifugal pump is operating in parallel with a positive displacement pump in an open water system. Each pump has the same maximum design pressure.

If pump discharge pressure increases to the maximum design pressure of each pump, the centrifugal pump will be operating at _____ flow and the positive displacement pump will be operating near _____ flow.

- A. minimum; minimum
- B. minimum; maximum rated
- C. maximum rated; minimum
- D. maximum rated; maximum rated

ANSWER: B.

TOPIC: 291004
KNOWLEDGE: K1.16 [2.5/2.7]
QID: B1424

A positive displacement pump is operating at a constant speed in an open system with its suction and discharge valves fully open. Which one of the following will increase if the pump discharge valve is throttled to 50 percent closed?

- A. Proximity to cavitation
- B. Required net positive suction head
- C. Pump flow rate
- D. Pump slip

ANSWER: D.

TOPIC: 291004
KNOWLEDGE: K1.16 [2.5/2.7]
QID: B1525 (P1526)

A positive displacement pump (PDP) is operating in an open system. PDP parameters are as follows:

PDP speed	= 480 rpm
PDP discharge pressure	= 1,000 psig
PDP suction pressure	= 10 psig
PDP flow rate	= 60 gpm

Which one of the following changes will cause PDP flow rate to exceed 100 gpm?

- A. A second identical discharge path is opened.
- B. PDP speed is increased to 900 rpm.
- C. PDP suction pressure is increased to 40 psig.
- D. Downstream system pressure is decreased to 500 psig.

ANSWER: B.

TOPIC: 291004
KNOWLEDGE: K1.16 [2.5/2.7]
QID: B1824 (P2126)

A variable-speed positive displacement pump is operating at 100 rpm with a flow rate of 60 gpm in an open system. To decrease pump flow rate to 25 gpm, pump speed must be decreased to approximately...

- A. 17 rpm.
- B. 33 rpm.
- C. 41 rpm.
- D. 62 rpm.

ANSWER: C.

TOPIC: 291004
KNOWLEDGE: K1.16 [2.5/2.7]
QID: B1919 (P1726)

An ideal (no slip) reciprocating positive displacement pump is operating to provide makeup water to a reactor coolant system that is being maintained at 1,000 psig. The discharge valve of the pump was found to be throttled to 80 percent open.

If the valve is subsequently fully opened, pump flow rate will _____ and pump head will _____.

- A. increase; decrease
- B. remain constant; decrease
- C. increase; remain constant
- D. remain constant; remain constant

ANSWER: B.

TOPIC: 291004
KNOWLEDGE: K1.16 [2.5/2.7]
QID: B2525 (P2526)

Which one of the following conditions will result in the greatest increase in volumetric flow rate in a water system with one positive displacement pump operating at 400 rpm and a discharge pressure of 100 psig?

- A. Increasing pump speed to 700 rpm.
- B. Decreasing pump discharge pressure to 40 psig.
- C. Starting a second identical positive displacement pump in series with the first.
- D. Starting a second identical positive displacement pump in parallel with the first.

ANSWER: D.

TOPIC: 291004
KNOWLEDGE: K1.16 [2.5/2.7]
QID: B2724

Which one of the following conditions will result in the greatest increase in volumetric flow rate from a positive displacement pump operating at 300 rpm and a discharge pressure of 100 psig?

- A. Increasing pump speed to 700 rpm.
- B. Decreasing pump discharge pressure to 30 psig.
- C. Starting a second identical positive displacement pump in series with the first.
- D. Starting a second identical positive displacement pump in parallel with the first.

ANSWER: A.

TOPIC: 291004
KNOWLEDGE: K1.16 [2.5/2.7]
QID: B2925 (P2926)

An ideal (no slip) reciprocating positive displacement pump is operating in an open system to provide makeup water to a coolant system that is being maintained at 800 psig. The discharge valve of the pump is full open.

If the pump discharge valve is subsequently throttled to 80 percent open, pump flow rate will _____ and pump head will _____.

- A. decrease; increase
- B. decrease; remain constant
- C. remain constant; increase
- D. remain constant; remain constant

ANSWER: C.

TOPIC: 291004
KNOWLEDGE: K1.16 [2.5/2.7]
QID: B3224 (P925)

A variable-speed positive displacement pump is operating at 100 rpm with a flow rate of 60 gpm in an open system. To decrease pump flow rate to 30 gpm, pump speed must be decreased to approximately...

- A. 25 rpm.
- B. 33 rpm.
- C. 50 rpm.
- D. 71 rpm.

ANSWER: C.

TOPIC: 291004
KNOWLEDGE: K1.16 [2.5/2.7]
QID: B3722 (P3730)

A rotary positive displacement pump (PDP) is being used to supply water to a piping system. The PDP is driven by an AC induction motor. The initial parameters are:

System pressure: 500 psig
PDP flow rate: 50 gpm
PDP motor current: 40 amps

After several hours, the PDP motor speed is increased such that the new PDP flow rate is 100 gpm. If system pressure does not change, what is the approximate value of the PDP motor current at the 100 gpm flow rate?

- A. 80 amps
- B. 160 amps
- C. 320 amps
- D. 640 amps

ANSWER: A.

TOPIC: 291004
KNOWLEDGE: K1.17 [2.5/2.6]
QID: B324 (P322)

The available net positive suction head for a pump may be expressed as...

- A. discharge pressure minus saturation pressure of the fluid being pumped.
- B. discharge pressure minus suction pressure.
- C. suction pressure minus saturation pressure of the fluid being pumped.
- D. suction pressure plus discharge pressure.

ANSWER: C.

TOPIC: 291004
KNOWLEDGE: K1.17 [2.5/2.6]
QID: B825

Which one of the following will occur as a direct result of operating a positive displacement pump with insufficient net positive suction head?

- A. Increased slip
- B. Decreased pump speed
- C. Increased flow rate
- D. Vapor binding

ANSWER: D.

TOPIC: 291004
KNOWLEDGE: K1.17 [2.5/2.6]
QID: B6113 (P6139)

Water enters a positive displacement pump at 50 psig and 90°F. What is the available net positive suction head for the pump?

- A. 80 feet
- B. 114 feet
- C. 133 feet
- D. 148 feet

ANSWER: D.

TOPIC: 291004
KNOWLEDGE: K1.18 [3.3/3.3]
QID: B1125 (P1425)

Which one of the following describes the proper location for a relief valve that will be used to prevent exceeding the design pressure of a positive displacement pump and associated piping?

- A. On the pump suction piping upstream of the suction isolation valve.
- B. On the pump suction piping downstream of the suction isolation valve.
- C. On the pump discharge piping upstream of the discharge isolation valve.
- D. On the pump discharge piping downstream of the discharge isolation valve.

ANSWER: C.

TOPIC: 291004
KNOWLEDGE: K1.18 [3.3/3.3]
QID: B2425 (P626)

What is the purpose of the safety/relief valve located between the pump outlet and the discharge isolation valve of most positive displacement pumps?

- A. Protect the pump and suction piping from overpressure if the discharge valve is open during system startup.
- B. Protect the pump and suction piping from overpressure if the suction valve is closed during pump operation.
- C. Protect the pump and discharge piping from overpressure if the discharge valve is closed during pump operation.
- D. Protect the pump and discharge piping from overpressure due to thermal expansion of pump contents when the pump is stopped with its suction valve closed.

ANSWER: C.

TOPIC: 291004
KNOWLEDGE: K1.19 [2.6/2.6]
QID: B1625

A pump that moves liquid by means of a piston within a cylinder that displaces a given volume of fluid for each stroke is a _____ pump.

- A. centrifugal
- B. screw
- C. reciprocating
- D. radial

ANSWER: C.

TOPIC: 291004
KNOWLEDGE: K1.19 [2.6/2.6]
QID: B2624 (P2626)

A section of reactor coolant piping is being hydrostatically tested to 1,400 psig using a positive displacement pump. The operating characteristics of the positive displacement pump are shown below, identifying ideal, expected, and actual pump performance.

Which one of the following could cause the observed difference between the expected and the actual pump performance?

- A. Pump internal leakage is greater than expected.
- B. Reactor coolant piping boundary valve leakage is greater than expected.
- C. Available NPSH has decreased more than expected, but remains slightly above required NPSH.
- D. A relief valve on the pump discharge piping has opened prior to its setpoint of 1,400 psig.

ANSWER: A.

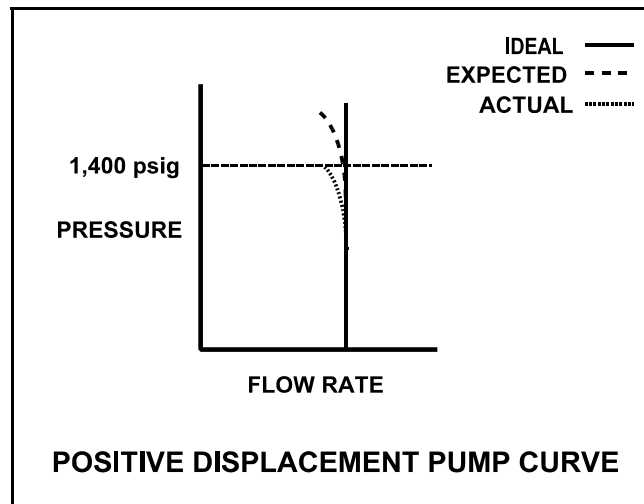

TOPIC: 291004
KNOWLEDGE: K1.19 [2.6/2.6]
QID: B3025 (P3024)

A pump is needed to supply fuel oil from a day tank to a diesel engine fuel injection system. The pump must maintain a nearly constant flow rate with a minimum of discharge pressure fluctuations as system pressure varies between 200 psig and 1,900 psig.

Which one of the following types of pumps would typically be used in this application?

- A. Axial flow centrifugal
- B. Radial flow centrifugal
- C. Rotary positive displacement
- D. Reciprocating positive displacement

ANSWER: C.

TOPIC: 291004
KNOWLEDGE: K1.19 [2.6/2.6]
QID: B5013 (P5012)

Use the following drawing of system and pump operating curves for a positive displacement pump with discharge relief valve protection to answer the following question.

A positive displacement pump is initially supplying water at 40 gpm with a pump discharge pressure of 400 psia. Then, pump speed is increased until pump flow rate is 80 gpm. What is the pump discharge pressure at the new pump flow rate of 80 gpm?

- A. 800 psia
- B. 1,000 psia
- C. 1,200 psia
- D. 1,600 psia

ANSWER: B.

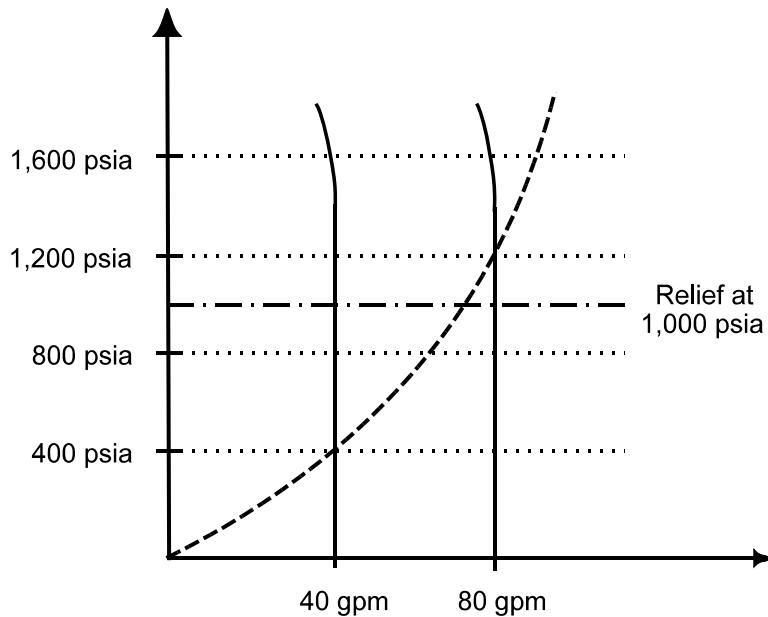

TOPIC: 291004
KNOWLEDGE: K1.19 [2.6/2.6]
QID: B5313 (P5313)

Use the following drawing of system and pump operating curves for an operating positive displacement pump with relief valve protection to answer the following question.

A positive displacement pump is initially supplying water at 40 gpm with a pump discharge pressure of 200 psia. Then, pump speed is increased until pump flow rate is 80 gpm. What is the pump discharge pressure at the new pump flow rate of 80 gpm?

- A. 400 psia
- B. 800 psia
- C. 1,000 psia
- D. 1,600 psia

ANSWER: B.

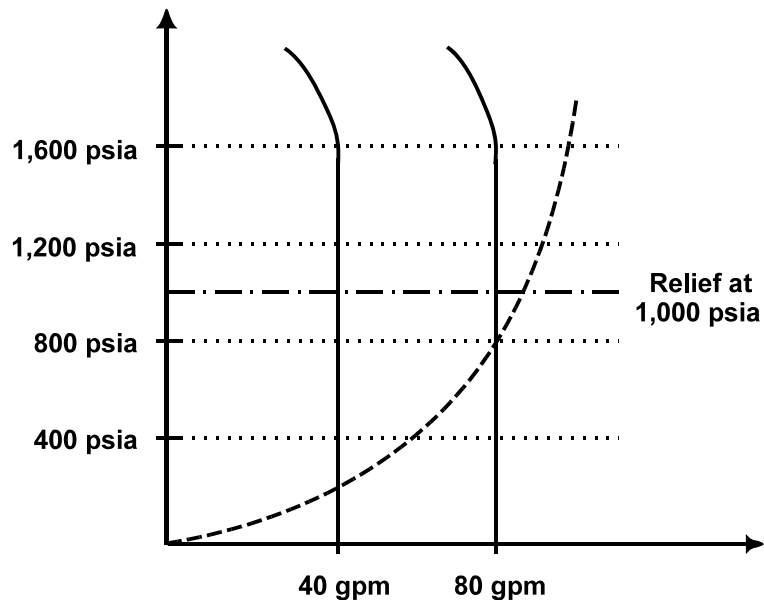

TOPIC: 291004
KNOWLEDGE: K1.20 [3.1/3.1]
QID: B117

Prior to starting a positive displacement pump, the discharge valve should be open to...

- A. prevent rupturing the pump casing.
- B. limit the pump motor starting time.
- C. ensure the pump casing fills by backflow.
- D. reduce pressure fluctuations in the discharge piping.

ANSWER: A.

TOPIC: 291004
KNOWLEDGE: K1.20 [3.1/3.1]
QID: B923

A _____ pump in a liquid system should be started with its discharge valve _____ to avoid rupturing the pump casing and/or discharge piping.

- A. centrifugal; fully closed
- B. centrifugal; fully open
- C. positive displacement; fully closed
- D. positive displacement; fully open

ANSWER: D.

TOPIC: 291004
KNOWLEDGE: K1.21 [3.1/3.0]
QID: B525 (P1923)

A positive displacement pump should be started with its suction valve _____ and its discharge valve _____.

- A. closed; closed
- B. closed; open
- C. open; closed
- D. open; open

ANSWER: D.

TOPIC: 291004
KNOWLEDGE: K1.21 [3.1/3.1]
QID: B1724 (P1722)

A positive displacement pump should be started with its suction valve _____ and its discharge valve _____.

- A. throttled; throttled
- B. throttled; fully open
- C. fully open; throttled
- D. fully open; fully open

ANSWER: D.