



REGULATORY GUIDE

OFFICE OF NUCLEAR REGULATORY RESEARCH

REGULATORY GUIDE 1.82

(Draft was issued as DG-1107)

WATER SOURCES FOR LONG-TERM RECIRCULATION COOLING FOLLOWING A LOSS-OF-COOLANT ACCIDENT

A. INTRODUCTION

General Design Criterion (GDC) 35, "Emergency Core Cooling"; GDC 38, "Containment Heat Removal"; and GDC 41, "Containment Atmosphere Cleanup," of Appendix A, "General Design Criteria for Nuclear Power Plants," to 10 CFR Part 50, "Domestic Licensing of Production and Utilization Facilities," require that systems be provided to perform specific functions, i.e., emergency core cooling, containment heat removal, and containment atmosphere clean up following a postulated design basis accident. Pursuant to GDC 36, "Inspection of Emergency Core Cooling System"; GDC 39, "Inspection of Containment Heat Removal System"; and GDC 42, "Inspection of Containment Atmosphere Cleanup Systems" of Appendix A to 10 CFR Part 50, these systems must be designed to permit appropriate periodic inspection of important components. Pursuant to GDC 37, "Testing of Emergency Core Cooling System"; GDC 40, "Testing of Containment Heat Removal System"; and GDC 43, "Testing of Containment Atmosphere Cleanup Systems" of Appendix A to 10 CFR Part 50, these systems must be designed to permit appropriate periodic testing to ensure their integrity and operability. In addition, GDC 1, "Quality Standards and Records," of Appendix A to 10 CFR Part 50 requires that structures, systems, and components important to safety be designed, fabricated, erected, and tested to quality standards commensurate with the importance of the safety functions to be performed.

Regulatory guides are issued to describe and make available to the public such information as methods acceptable to the NRC staff for implementing specific parts of the NRC's regulations, techniques used by the staff in evaluating specific problems or postulated accidents, and data needed by the NRC staff in its review of applications for permits and licenses. Regulatory guides are not substitutes for regulations, and compliance with them is not required. Methods and solutions different from those set out in the guides will be acceptable if they provide a basis for the findings requisite to the issuance or continuance of a permit or license by the Commission.

This guide was issued after consideration of comments received from the public. Comments and suggestions for improvements in these guides are encouraged at all times, and guides will be revised, as appropriate, to accommodate comments and to reflect new information or experience. Written comments may be submitted to the Rules and Directives Branch, ADM, U.S. Nuclear Regulatory Commission, Washington, DC 20555-0001.

Regulatory guides are issued in ten broad divisions: 1, Power Reactors; 2, Research and Test Reactors; 3, Fuels and Materials Facilities; 4, Environmental and Siting; 5, Materials and Plant Protection; 6, Products; 7, Transportation; 8, Occupational Health; 9, Antitrust and Financial Review; and 10, General.

Single copies of regulatory guides (which may be reproduced) may be obtained free of charge by writing the Distribution Services Section, U.S. Nuclear Regulatory Commission, Washington, DC 20555-0001, or by fax to (301)415-2289, or by email to DISTRIBUTION@NRC.GOV. Electronic copies of this guide and other recently issued guides are available at NRC's home page at WWW.NRC.GOV through the Electronic Reading Room, Accession Number ML033140347.

This guide describes methods acceptable to the NRC staff for implementing these requirements with respect to the sumps and suppression pools performing the functions of water sources for emergency core cooling, containment heat removal, or containment atmosphere clean up. The guide also provides guidelines for evaluating the adequacy of the availability of the sump and suppression pool for long-term recirculation cooling following a loss-of-coolant accident (LOCA). This guide applies to light-water-cooled reactors.

Additional information is provided in NRC Bulletin 2003-01, "Potential Impact of Debris Blockage on Emergency Sump Recirculation at Pressurized-Water Reactors"; NRC Bulletin 96-03, "Potential Plugging of Emergency Core Cooling Suction Strainers by Debris in Boiling Water Reactors"; NRC Bulletin 95-02, "Unexpected Clogging of a Residual Heat Removal Pump Strainer While Operating in Suppression Pool Cooling Mode"; NRC Bulletin 93-02, "Debris Plugging of Emergency Core Cooling Suction Strainers"; Supplement 1 to NRC Bulletin 93-02, "Debris Plugging of Emergency Core Cooling Suction Strainers"; Generic Letter 85-22, "Potential for Loss of Post-LOCA Recirculation Capability Due to Insulation Debris Blockage"; and Generic Letter 97-04, "Assurance of Sufficient Net Positive Suction Head for Emergency Core Cooling and Containment Heat Removal Pumps."

This regulatory guide has been revised to enhance the debris blockage evaluation guidance for pressurized water reactors. Research after the issuance of Revision 2 indicated that the previous guidance was not comprehensive enough to ensure adequate evaluation of a pressurized water reactor (PWR) plant's susceptibility to the detrimental effects caused by debris accumulation on debris interceptors (e.g., trash racks and sump screens). The sections pertaining to PWRs have been changed, and minor changes have been made to the sections on boiling water reactors (BWRs) to make them consistent with current staff positions as described in the Safety Evaluation on the Boiling Water Reactor Owners Group's (BWROG's) Utility Resolution Guide (URG) for ECCS Suction Strainer Blockage (1998).

This regulatory guide has also been revised to include guidance previously provided in Regulatory Guide 1.1, "Net Positive Suction Head for Emergency Core Cooling and Containment Heat Removal Pumps." The provisions of Regulatory Guide 1.1 have been updated in this guide to reflect the results of the NRC's review of responses to Generic Letter 97-04, "Assurance of Sufficient Net Positive Suction Head for Emergency Core Cooling and Containment Heat Removal Pumps," dated October 7, 1997.

The information collections contained in this regulatory guide are covered by the requirements of 10 CFR Part 50, which were approved by the Office of Management and Budget (OMB), approval number 3150-0011. The NRC may not conduct or sponsor, and a person is not required to respond to, a request for information or an information collection requirement unless the requesting document displays a currently valid OMB control number.

B. DISCUSSION

GENERAL

The primary safety concerns regarding long-term recirculation cooling following a LOCA are (1) LOCA-generated and pre-LOCA debris materials transported to the debris interceptors (i.e., trash racks, debris screens, suction strainers) resulting in adverse blockage effects, (2) post-LOCA hydraulic effects, particularly air ingestion, and (3) the combined effects of items (1) and (2) on long-term recirculation pumping operability (i.e., effect on net positive suction head (NPSH) available at the pump inlet). These emergency core cooling system (ECCS) safety concerns extend to the containment spray systems (CSS) for plants with containment designs in which the containment spray systems draw suction from the recirculation sump. In some cases, the containment spray systems would draw from the recirculation sump significantly earlier than would the ECCS.

Debris resulting from a LOCA, together with debris that exists before a LOCA, could block the emergency core cooling (ECC) debris interceptors and result in degradation or loss of NPSH margin. Such debris can be divided into the following categories: (1) debris that is generated by the LOCA and is transported by blowdown forces (e.g., insulation, paint), (2) debris that is generated or transported by washdown, and (3) other debris that existed before a LOCA (e.g., corrosion material, sludge in a BWR suppression pool) and that may become suspended in the containment sump or suppression pool. Debris can be further subdivided into (1) debris that has a high density and could sink but is still subject to fluid transport if local recirculation flow velocities are high enough, (2) debris that has an effective specific gravity near 1.0 and tends to remain suspended or sink slowly and will nonetheless be transported by very low velocities or local fluid turbulence phenomena, and (3) debris that will float indefinitely by virtue of low density and will be transported to and possibly through the debris interceptors. Debris generation, early debris transport, long-term debris transport, and attendant blockage of debris interceptors should be evaluated to ensure that the ability of the ECCS to provide long-term post-LOCA core cooling is not jeopardized. All potential debris sources should be evaluated, including but not limited to, the fire barrier material, insulation materials (e.g., fibrous, ceramic, and metallic), filters, corrosion material, and paints or coatings. Relevant information for such evaluations is provided in the Regulatory Position and in Appendix A to this guide. Additional information relative to the above concerns may be found in Revision 1 of NUREG-0897, NUREG/CR-2758, NUREG/CR-2759, NUREG/CR-2760, NUREG/CR-2761, NUREG/CR-2772, NUREG/CR-2791, NUREG/CR-2792, NUREG/CR-2982, NUREG/CR-3170, NUREG/CR-3394, NUREG/CR-3616, NUREG/CR-6224, NUREG/CR-6369, NUREG/CR-6762, NUREG/CR-6772, NUREG/CR-6773, NRC Information Notice 94-57, NRC Information Notice 95-06, NRC Information Notice 95-47, Regulatory Guide 1.1, Safety Evaluation on the BWROG's URG for ECCS Suction Strainer Blockage, NEDO-32686, Generic Letter 97-04, and Generic Letter 98-04. A current knowledge base describing results of research on the BWR suction-strainer and PWR sump screen blockage is provided in NUREG/CR-6808.

This regulatory guide provides separate guidance for PWR and BWR plants based on the design features of currently operating reactors. Advanced PWR or BWR designs may employ

design features that this regulatory guide only associates with the opposite reactor design (e.g., an advanced PWR design that employs an in-containment refueling water storage tank that is similar to the suppression pool of a current BWR design, or an advanced BWR design that employs a large dry containment that is similar to a current PWR design). Therefore, for advanced PWR and BWR designs, the guidance provided in both the PWR and BWR sections of this regulatory guide that is appropriate and consistent with the plant's design features should be considered.

In the process of resolving the strainer blockage issue associated with existing BWRs, advanced strainer designs were developed (e.g., stacked disk strainer) and installed. Similarly, it is anticipated that alternative sump screen designs may be developed for the currently licensed PWRs. Much of the guidance in this regulatory guide relates to sump designs currently in use by PWR plants (e.g., vertically or horizontally oriented screens). However, the regulatory guide is not intended to show any preference toward a particular sump screen orientation. The concepts and the intent of the guidance apply to all alternative sump screen designs.

PRESSURIZED WATER REACTORS

In PWRs, the containment emergency sumps provide for the collection of reactor coolant and chemically reactive spray solutions following a LOCA; thus, the sumps serve as water sources to support long-term recirculation for the functions of residual heat removal, emergency core cooling, containment cooling, and containment atmosphere cleanup. These water sources, the related pump inlets, and the piping between the sources and inlets are important safety components. In this guide, the term ECCS implicitly includes the containment spray systems (CSS), and the sumps servicing the ECCS and the CSS are referred to as ECC sumps. Features and relationships of the ECC sumps pertinent to this guide are shown in Figure 1. In operating PWRs, the ECC sump designs may vary from this figure (e.g., in some plants sump screens may be located below the floor level). A more comprehensive description of various ECC sump designs is included in NUREG/CR-6762.

The design of PWR sumps and their outlets includes consideration of the avoidance of air ingestion and other undesirable hydraulic effects (e.g., circulatory flow patterns, outlets leading to high head losses). The location and size of the sump outlets within ECC sumps is important in order to minimize air ingestion since ingestion is a function of submergence level and velocity in the outlet piping. It has been experimentally determined for PWRs that air ingestion can be minimized or eliminated if the sump hydraulic design considerations provided in Appendix A to this guide are followed. Revision 1 of NUREG-0897, NUREG/CR-2758, NUREG/CR-2761, and NUREG/CR-2792 provide additional technical information relevant to sump ECC hydraulic performance and design guidelines.

In order for a centrifugal pump to perform its safety function, there must be adequate margin between the available NPSH and the required NPSH.¹ The available NPSH is the total suction head of liquid absolute, determined at the first stage impeller datum, less the absolute

¹ANSI/HI 1.1-1.5-1994, "American National Standard for Centrifugal Pumps for Nomenclature, Definitions, Application and Operation," which this guide references, defines NPSH parameters, including required NPSH. See Appendix A of this guide. Required NPSH, as defined in in ANSI/HI 1.1-1.5-1994, is not an NRC regulatory requirement.

vapor pressure of the liquid. The required NPSH is the amount of suction head, over vapor pressure, required to prevent more than 3% loss in total head of the first stage of the pump at a specific capacity.

NPSH margin is the amount by which available NPSH exceeds required NPSH. Failure to provide and maintain adequate NPSH margin for the ECCS pumps could result in cavitation and their subsequent failure to deliver the amount of water assumed in design basis LOCA calculations. Failure to provide and maintain adequate NPSH margin for the containment heat removal pumps could result in pressurization of the containment above the design pressure and an increase in the offsite and control room radiological doses.

The head loss due to debris is not included in the definition of the available NPSH. The value of the head loss due to debris should be compared to the value of the NPSH margin in order to determine whether pump cavitation will occur.

Predicted performance of the ECCS and the containment heat removal pumps should be independent of the calculated increases in containment pressure caused by postulated LOCAs in order to ensure reliable operation under a variety of possible accident conditions. For example, if proper operation of the ECCS or the containment heat removal system depends on containment pressure above a specified minimum amount, operation of these systems at a containment pressure less than this amount (resulting, for example, from impaired containment integrity or operation of the containment heat removal systems at too high a rate) could significantly affect the ability of this system to accomplish its safety functions. However, for some operating reactors, some credit for containment accident pressure may be necessary. This should be minimized to the extent possible.

ANSI/HI 1.1-1.5-1994 specifies a method of accounting for the decrease in required NPSH with an increase in temperature of the pumped fluid. This method is subject to restrictions specified in the standard dealing with experience with the specific pump, the amount of air dissolved in the fluid, and the transient nature of the pressure and temperature of the pumped fluid. The staff considers it prudent to not take credit for the reduction in required NPSH that is due to the temperature of the pumped fluid because of the uncertainty in these factors.

Transient NPSH calculations should be performed to ensure that the most limiting conditions are chosen and that the results are conservative.

Placement of the ECC sumps at the lowest level practical ensures maximum use of available recirculation coolant. Areas within the containment in which coolant could accumulate during the containment spray period are provided, as necessary, with drains or flow paths to the sumps to prevent coolant holdup. It is also a concern that these drains or flow paths may themselves be blocked either totally or partially, diverting water away from the active sump region. This guide does not address the design of such drains or flow paths. Because debris can migrate to the sump via these drains or paths, they are best terminated in a manner that will prevent debris from being transported to and accumulating on or within the ECC sumps.

Containment drainage sumps are used to collect and monitor normal leakage flow for leakage detection systems within containments. They are separated from the ECC sumps and are located at an elevation lower than the ECC sumps to minimize inadvertent spillover into the ECC sumps from minor leaks or spills within containment. The floor adjacent to the ECC sumps would normally slope downward, away from the ECC sumps, toward the drainage collection sumps. This downward slope away from the ECC sumps will minimize the transport and collection of debris against the debris interceptors. High-density debris may be swept along the floor by the flow toward the trash rack. A debris curb upstream of and in close proximity to the rack will decrease the amount of such debris reaching the trash rack and debris screens. Debris blockage of the sump screen may also be mitigated by placement of an active device or system that performs an active function to prevent debris (which could block restrictions or damage components in the systems served by the ECC pumps) from entering the ECC pump suction lines, to remove debris from the sump screen and flow stream upstream of the ECC pumps, or to mitigate any detrimental effects of debris accumulation. Examples of active mitigation systems are listed in Appendix B.

It is necessary to protect sump outlets with sump screens and trash racks of sufficient strength to withstand the vibratory motion of seismic events, to resist jet loads and impact loads that could be imposed by missiles that may be generated by the initial LOCA, and to withstand the differential pressure loads imposed by the accumulation of debris. Considerations for selecting materials for the debris interceptors include long periods of inactivity, i.e., no submergence, and periods of operation involving partial or full submergence in a fluid that may contain chemically reactive materials. Isolation of the ECC sumps from high-energy pipe lines is an important consideration in protection against missiles, and it is necessary to shield the screens and racks adequately from impacts of ruptured high-energy piping and associated jet loads. When the screen and rack structures are oriented vertically or nearly vertically, the adverse effects from large pieces of debris (e.g., partially torn insulation blankets or damaged reflective metallic insulation cassettes) collecting on them will be reduced. Consistent with the plant licensing basis single-failure criterion, redundant ECC sumps and sump outlets should be separated to the extent practical to reduce the possibility that a single event could render both sumps inoperable.

It is generally expected that the water surface will be above the top of the debris interceptor structure after completion of the safety injection and before the ECC sumps become operational. However, the uncertainties about the extent of water coverage on the structure, the amount of floating debris that may accumulate, and the potential for early clogging do not favor the use of a horizontal top interceptor. Therefore, in the computation of available interceptor surface area, no credit may be taken for any horizontal interceptor surface unless plant evaluations that adequately account for inherent water source uncertainties demonstrate that the horizontal surface will be submerged at the time of recirculation. For certain sump designs, it is preferable that the top of the interceptor structure be a solid cover plate that will provide additional protection from LOCA-generated loads and be designed to provide for the venting of any trapped air. It is possible that ECC sumps in some plants may not be submerged completely under water at the time of recirculation, either because of unique sump designs or uncertainties in water level estimates. Such partially submerged sumps may be subject to failure criteria other than NPSH margin as discussed in Regulatory Position 1.3.4.4 and Appendix A of this guide. In the case of partially

submerged sumps, credit should only be given for the portion of the sump screen that is expected to be submerged as a function of time.

All debris that is transportable to the trash rack, the debris screen, and the outlets needs to be analyzed for head loss effects. Debris that is small enough to pass through the trash rack and the debris screen needs to be analyzed for head loss effects together with the fibrous debris bed that may filter small particulates. Blockage of the trash rack, sump screen, and sump outlet is a function of the types, combinations, sizes, shapes, and quantities of insulation debris that can be transported to these components. A vertical or nearly vertical inner debris screen located above the containment floor level would minimize the deposition or settling of debris on screen surfaces and thus help to ensure the greatest possible free flow through the fine inner debris screen. Similarly, locating the sump screens and trash racks above the containment floor level, preferably on a pedestal, minimizes the potential for debris buildup. NUREG/CR-6773 provides test results for transport of various types, sizes, and shapes of debris.

The size of openings in the screens is dependent on the physical restrictions that may exist in the systems that are supplied with coolant from the ECC sump. The size of the mesh of the fine debris screen is determined by considering a number of factors, including the size of the openings in the containment spray nozzles; coolant channel openings in the core fuel assemblies; the presence of fuel assembly inlet debris screens; the minimum dimension within the flow-path (e.g., high pressure safety injection (HPSI) throttle valves); such pump design characteristics as seals, bearings, and impeller running clearances; the clean screen head loss; and the consequences of the downstream accumulation of debris passing through the sump screen.

As noted above, degraded pumping can be caused by a number of factors, including plant design and layout. In particular, debris blockage effects on debris interceptor and sump outlet configurations and post-LOCA hydraulic conditions (e.g., air ingestion) must be considered in a combined manner. Small amounts of air ingestion, i.e., 2% or less, will not lead to severe pumping degradation if the required NPSH from the pump manufacturer's curves is increased based on the calculated air ingestion. Thus it is important to use the combined results of all post-LOCA effects to estimate NPSH margin as calculated for the pump inlet. Appendix A to this guide provides information for estimating NPSH margins in PWR sump designs where estimated levels of air ingestion are low (2% or less). Revision 1 of NUREG-0897 and NUREG/CR-2792 provide additional technical findings relevant to NPSH effects on pumps performing the functions of residual heat removal, emergency core cooling, and containment atmosphere cleanup. When air ingestion is 2% or less, compensation for its effects may be achieved without redesign if the available NPSH is greater than the required NPSH plus a margin based on the percentage of air ingestion. If air ingestion is not small, redesign of one or more of the recirculation loop components may be necessary.

BOILING WATER REACTORS

In BWRs, the suppression pool, in conjunction with the primary containment, downcomers, and vents, serves as the water source for effecting long-term recirculation cooling. This source, the related pump suction inlets, and the piping between them are important safety

components. Features and relationships of the suppression pool pertinent to this guide are shown in Figure 2. Concerns with the performance of the suppression pool hydraulics and ECC pump suction strainers include consideration of air ingestion effects, blockage of suction strainers (by debris), and the combined effects of these items on the operability of the ECC pumps (e.g., the impact on NPSH available at the pump inlets). Revision 1 of NUREG-0897 and NUREG/CR-2772 provide data on the performance and air ingestion characteristics of BWR suction strainer configurations.

In order for a centrifugal pump to perform its safety function, there must be adequate margin between the available and the required NPSH. Failure to provide and maintain adequate NPSH for the emergency core cooling system pumps could result in cavitation and their subsequent failure to deliver the amount of water assumed in design basis LOCA calculations. For BWRs that credit containment spray systems in the safety analyses, failure to provide and maintain adequate NPSH of the containment heat removal pumps could result in overpressurization of the containment and an increase in the offsite and control room radiological dose.

Since the safety of a nuclear power plant depends on the expected performance of the centrifugal pumps in the ECCS and the containment heat removal system, it is important to maintain adequate margin between the available and required NPSH under all potential conditions.

The available NPSH is the total suction head of liquid absolute, determined at the first stage impeller datum, less the absolute vapor pressure of the liquid. The required NPSH is the amount of suction head, over vapor pressure, required to prevent more than 3% loss in total head of the first stage of the pump at a specific capacity.

Predicted performance of the ECC and the containment heat removal pumps should be independent of the calculated increases in containment pressure caused by postulated LOCAs in order to ensure reliable operation under a variety of possible accident conditions. For example, if proper operation of the ECCS or the containment heat removal system depends on containment pressure above a specified minimum amount, operation of these systems at a containment pressure less than this amount (resulting, for example, from impaired containment integrity or operation of the containment heat removal systems at too high a rate) could significantly affect the ability of this system to accomplish its safety functions. However, for some operating reactors, credit for containment accident pressure may be necessary. This should be minimized to the extent possible.

ANSI/HI 1.1-1.5-1994 specifies a method of accounting for the decrease in required NPSH with an increase in temperature of the pumped fluid. This method is subject to restrictions specified in the standard dealing with experience with the specific pump, the amount of air dissolved in the fluid, and the transient nature of the pressure and temperature of the pumped fluid. The staff has considered it prudent to not take credit for the reduction in required NPSH that is due to the temperature of the pumped fluid because of the uncertainty in these factors.

Transient NPSH calculations should be performed to ensure that the most limiting conditions are chosen and that the results are conservative.

It is desirable to consider the use of debris interceptors (i.e., suction strainers) in BWR designs to protect the pump inlets and NPSH margins. The debris interceptor can be a passive suction strainer or an active suction strainer or active strainer system. A passive suction strainer is a device that prevents debris, which may block restrictions in the systems served by the ECC pumps or damage components, from entering the ECC pump suction line by accumulating debris on a porous surface. An example of a passive suction strainer is a truncated-cone-shaped, perforated plate strainer. An active suction strainer or an active strainer system is a device or system that will take some action to prevent debris, which may block restrictions in the systems served by the ECC pumps or damage components, from entering the ECC pump suction lines, remove debris from the flow stream upstream of the ECC pumps, or mitigate any detrimental effects of debris accumulation. Examples of active mitigation systems are listed in Appendix B.

Suppression pool debris transport analysis should include the effects of LOCA progression because LOCAs of different sizes will affect the duration of LOCA-related hydrodynamic phenomena (e.g., condensation oscillation, chugging). The LOCA-related hydrodynamic phenomena and long-term recirculation hydrodynamic conditions will affect the transport of debris in the suppression pool.

Debris that is transported to the suppression pool during a LOCA, or that is present in the suppression pool prior to a LOCA (NRC Information Notices 94-57, 95-06, and 95-47), could block or damage the suction strainers and needs to be analyzed for head loss effects. This head loss analysis should include filtering of particulate debris by the accumulated debris bed. The head loss characteristics of a debris bed will be a function of the types and quantities of the debris, suction strainer approach velocities, and LOCA-related hydrodynamic phenomena in the suppression pool.

C. REGULATORY POSITION

This section states regulatory positions on design criteria, performance standards, and analysis methods that relate to PWRs (Regulatory Position 1) and BWRs (Regulatory Position 2). As stated in the Introduction to this guide, the purpose of the guidance is to identify information and methods acceptable to the NRC staff for evaluating analytical techniques and implementing regulations related to water sources for long-term cooling of both existing and future reactor systems. The guidance, to a great extent, is generic and it may go beyond the current design of some operating reactor systems.

1. PRESSURIZED WATER REACTORS

1.1 Features Needed To Minimize the Potential for Loss of NPSH

The ECC sumps, which are the source of water for such functions as ECC and containment heat removal following a LOCA, should contain an appropriate combination of the following features and capabilities to ensure the availability of the ECC sumps for long-term cooling. The

adequacy of the combinations of the features and capabilities should be evaluated using the criteria and assumptions in Regulatory Position 1.3.

1.1.1 ECC Sumps, Debris Interceptors, and Debris Screens

- 1.1.1.1** A minimum of two sumps should be provided, each with sufficient capacity to service one of the redundant trains of the ECCS and CSS. Distribution of water sources and containment spray between the sumps should be considered in the calculation of boron concentration in the sumps for evaluating post-LOCA subcriticality and shutdown margins. Typically, these calculations are performed assuming minimum boron concentration and minimum dilution sources. Similar considerations should also be given in the calculation of time for Hot Leg Switchover, which is calculated assuming maximum boron concentration and a minimum of dilution sources.
- 1.1.1.2** To the extent practical, the redundant sumps should be physically separated by structural barriers from each other and from high-energy piping systems to preclude damage from LOCA, and, if within the design basis, main steam or main feedwater break consequences to the components of both sumps (e.g., trash racks, sump screens, and sump outlets) by whipping pipes or high-velocity jets of water or steam.
- 1.1.1.3** The sumps should be located on the lowest floor elevation in the containment exclusive of the reactor vessel cavity to maximize the pool depth relative to the sump screens. The sump outlets should be protected by appropriately oriented (e.g., at least two vertical or nearly vertical) debris interceptors: (1) a fine inner debris screen and (2) a coarse outer trash rack to prevent large debris from reaching the debris screen. A curb should be provided upstream of the trash racks to prevent high-density debris from being swept along the floor into the sump. To be effective, the height of the curb should be appropriate for the pool flow velocities, as the debris can jump over a curb if the velocities are sufficiently high. Experiments documented in NUREG/CR-6772 and NUREG/CR-6773 have demonstrated that substantial quantities of settled debris could transport across the sump pool floor to the sump screen by sliding or tumbling.
- 1.1.1.4** The floor in the vicinity of the ECC sump should slope gradually downward away from the sump to further retard floor debris transport and reduce the fraction of debris that might reach the sump screen.
- 1.1.1.5** All drains from the upper regions of the containment should terminate in such a manner that direct streams of water, which may contain entrained debris, will not directly impinge on the debris interceptors or discharge in close proximity to the sump. The drains and other narrow pathways that connect compartments with potential break locations to the ECC sump should be designed to ensure that they would not become blocked by the debris; this is to ensure that water needed for an adequate NPSH margin could not be held up or diverted from the sump.

- 1.1.1.6** The strength of the trash racks should be adequate to protect the debris screens from missiles and other large debris. Trash racks and sump screens should be capable of withstanding the loads imposed by expanding jets, missiles, the accumulation of debris, and pressure differentials caused by post-LOCA blockage under design-basis flow conditions. When evaluating impact from potential expanding jets and missiles, credit for any protection to trash racks and sump screens offered by surrounding structures or credit for remoteness of trash racks and sump screens from potential high energy sources should be justified.
- 1.1.1.7** Where consistent with overall sump design and functionality, the top of the debris interceptor structures should be a solid cover plate that is designed to be fully submerged after a LOCA and completion of the ECC injection. The cover plate is intended to provide additional protection to debris interceptor structures from LOCA-generated loads. However, the design should also provide means for venting of any air trapped underneath the cover.
- 1.1.1.8** The debris interceptors should be designed to withstand the inertial and hydrodynamic effects that are due to vibratory motion of a safe shutdown earthquake (SSE) following a LOCA without loss of structural integrity.
- 1.1.1.9** Materials for debris interceptors and sump screens should be selected to avoid degradation during periods of both inactivity and operation and should have a low sensitivity to such adverse effects as stress-assisted corrosion that may be induced by chemically reactive spray during LOCA conditions.
- 1.1.1.10** The debris interceptor structures should include access openings to facilitate inspection of these structures, any vortex suppressors, and the sump outlets.
- 1.1.1.11** A sump screen design (i.e., size and shape) should be chosen that will avoid the loss of NPSH from debris blockage during the period that the ECCS is required to operate in order to maintain long-term cooling or maximize the time before loss of NPSH caused by debris blockage when used with an active mitigation system (see Regulatory Position 1.1.4).
- 1.1.1.12** The possibility of debris-clogging flow restrictions downstream of the sump screen should be assessed to ensure adequate long term recirculation cooling, containment cooling, and containment pressure control capabilities. The size of the openings in the sump debris screen should be determined considering the flow restrictions of systems served by the ECCS sump. The potential for long thin slivers passing axially through the sump screen and then reorienting and clogging at any flow restriction downstream should be considered.

Consideration should be given to the buildup of debris at downstream locations such as the following: containment spray nozzle openings, HPSI throttle valves, coolant channel openings in the core fuel assemblies, fuel assembly inlet debris screens, ECCS

pump seals, bearings, and impeller running clearances. If it is determined that a sump screen with openings small enough to filter out particles of debris that are fine enough to cause damage to ECCS pump seals or bearings would be impractical, it is expected that modifications would be made to ECCS pumps or ECCS pumps would be procured that can operate long term under the probable conditions.

- 1.1.1.13** ECC and containment spray pump suction inlets should be designed to prevent degradation of pump performance through air ingestion and other adverse hydraulic effects (e.g., circulatory flow patterns, high intake head losses).
- 1.1.1.14** All drains from the upper regions of the containment building, as well as floor drains, should terminate in such a manner that direct streams of water, which may contain entrained debris, will not discharge downstream of the sump screen, thereby bypassing the sump screen.
- 1.1.1.15** Advanced strainer designs (e.g., stacked disc strainers) have demonstrated capabilities that are not provided by simple flat plate or cone-shaped strainers or screens. For example, these capabilities include built-in debris traps where debris can collect on surfaces while keeping a portion of the screen relatively free of debris. The convoluted structure of such strainer designs increases the total screen area, and these structures tend to prevent the condition referred to as the thin bed effect. It may be desirable to include these capabilities in any new sump strainer/screen designs. The performance characteristics and effectiveness of such designs should be supported by appropriate test data for any particular intended application.

1.1.2 Minimizing Debris

The debris (see Regulatory Position 1.3.2) that could accumulate on the sump screen should be minimized.

- 1.1.2.1** Cleanliness programs should be established to clean the containment on a regular basis, and plant procedures should be established for control and removal of foreign materials from the containment.
- 1.1.2.2** Insulation types (e.g., fibrous and calcium silicate) that can be sources of debris that is known to more readily transport to the sump screen and cause higher head losses may be replaced with insulations (e.g., reflective metallic insulation) that transport less readily and cause less severe head losses once deposited onto the sump screen. If insulation is replaced or otherwise removed during maintenance, abatement procedures should be established to avoid generating latent debris in the containment.
- 1.1.2.3** To minimize potential debris caused by chemical reaction of the pool water with metals in the containment, exposure of bare metal surfaces (e.g., scaffolding) to containment cooling water through spray impingement or immersion should be minimized either by removal or by chemical-resistant protection (e.g., coatings or jackets).

1.1.3 Instrumentation

If relying on operator actions to mitigate the consequences of the accumulation of debris on the ECC sump screens, safety-related instrumentation that provides operators with an indication and audible warning of impending loss of NPSH for ECCS pumps should be available in the control room.

1.1.4 Active Sump Screen System

An active device or system (see examples in Appendix B) may be provided to prevent the accumulation of debris on a sump screen or to mitigate the consequences of accumulation of debris on a sump screen. An active system should be able to prevent debris that may block restrictions found in the systems served by the ECC pumps from entering the system. The operation of the active component or system should not adversely affect the operation of other ECC components or systems. Performance characteristics of an active sump screen system should be supported by appropriate test data that address head loss performance.

1.1.5 Inservice Inspection

To ensure the operability and structural integrity of the trash racks and screens, access openings are necessary to permit inspection of the ECC sump structures and outlets. Inservice inspection of racks, screens, vortex suppressors, and sump outlets, including visual examination for evidence of structural degradation or corrosion, should be performed on a regular basis at every refueling period downtime. Inspection of the ECC sump components late in the refueling period will ensure the absence of construction trash in the ECC sump area.

1.2 Evaluation of Alternative Water Sources

To demonstrate that a combination of the features and actions listed above are adequate to ensure long-term cooling and that the five criteria of 10 CFR 50.46(b) will be met following a LOCA, an evaluation using the guidance and assumptions in Regulatory Position 1.3 should be conducted. If a licensee is relying on operator actions to prevent the accumulation of debris on ECC sump screens or to mitigate the consequences of the accumulation of debris on the ECC sump screens, an evaluation should be performed to ensure that the operator has adequate indications, training, time, and system capabilities to perform the necessary actions. If not covered by plant-specific emergency operating procedures, procedures should be established to use alternative water sources that will be activated when unacceptable head loss renders the sump inoperable. The valves needed to align the ECCS and containment spray systems (taking suction from the recirculation sumps) with an alternative water source should be periodically inspected and maintained.

1.3 Evaluation of Long-Term Recirculation Capability

The following techniques, assumptions, and guidance should be used in a deterministic, plant-specific evaluation to ensure that any implementation of a combination of the features and capabilities listed in Regulatory Position 1.1 are adequate to ensure the availability of a reliable water source for long-term recirculation following a LOCA. The assumptions and guidance listed below can also be used to develop test conditions for sump screens.

Evaluation and confirmation of (1) sump hydraulic performance (e.g., geometric effects, air ingestion), (2) debris effects (e.g., debris transport, interceptor blockage, head loss), and (3) the combined impact on NPSH available at the pump inlet should be performed to ensure that long-term recirculation cooling can be accomplished following a LOCA. Such an evaluation should arrive at a determination of NPSH margin calculated at the pump inlet. An assessment should also be made of the susceptibility to debris blockage of the containment drainage flow paths to the recirculation sump; this is to protect against reduction in available NPSH if substantial amounts of water are held up or diverted away from the sump. An assessment should be made of the susceptibility of the flow restrictions in the ECCS and CSS recirculation flow paths downstream of the sump screens and of the recirculation pump seal and bearing assembly design to failure from particulate ingestion and abrasive effects to protect against degradation of long-term recirculation pumping capacity.

1.3.1 Net Positive Suction Head of ECCS and Containment Heat Removal Pumps

1.3.1.1 ECC and containment heat removal systems should be designed so that sufficient available NPSH is provided to the system pumps, assuming the maximum expected temperature of pumped fluid and no increase in containment pressure from that present prior to the postulated LOCA. (See Regulatory Position 1.3.1.2.)

For sump pools with temperatures less than 212 °F, it is conservative to assume that the containment pressure equals the vapor pressure of the sump water. This ensures that credit is not taken for the containment pressurization during the transient.

For subatmospheric containments, this guidance should apply after the injection phase has terminated. For subatmospheric containments, prior to termination of the injection phase, NPSH analyses should include conservative predictions of the containment atmospheric pressure and sump water temperature as a function of time.

1.3.1.2 For certain operating PWRs for which the design cannot be practicably altered, conformance with Regulatory Position 1.3.1.1 may not be possible. In these cases, no additional containment pressure should be included in the determination of available NPSH than is necessary to preclude pump cavitation. Calculation of available containment pressure and sump water temperature as a function of time should underestimate the expected containment pressure and overestimate the sump water temperature when determining available NPSH for this situation.

1.3.1.3 For certain operating reactors for which the design cannot be practicably altered, if credit is taken for operation of an ECCS or containment heat removal pump in cavitation, prototypical pump tests should be performed along with post-test examination of the pump to demonstrate that pump performance will not be degraded and that the pump continues to meet all the performance criteria assumed in the safety analyses. The time period in the safety analyses during which the pump may be assumed to operate while cavitating should not be longer than the time for which the performance tests demonstrate that the pump meets performance criteria.

- 1.3.1.4** The decay and residual heat produced following accident initiation should be included in the determination of the water temperature. The uncertainty in the determination of the decay heat should be included in this calculation. The residual heat should be calculated with margin.
- 1.3.1.5** The hot channel correction factor specified in ANSI/HI 1.1-1.5-1994 should not be used in determining the margin between the available and required NPSH for ECCS and containment heat removal system pumps.
- 1.3.1.6** The calculation of available NPSH should minimize the height of water above the pump suction (i.e., the level of water on the containment floor). The calculated height of water on the containment floor should not consider quantities of water that do not contribute to the sump pool (e.g., atmospheric steam, pooled water on floors and in refueling canals, spray droplets and other falling water, etc.). The amount of water in enclosed areas that cannot be readily returned to the sump should not be included in the calculated height of water on the containment floor.
- 1.3.1.7** The calculation of pipe and fitting resistance and the calculation of the nominal screen resistance without blockage by debris should be done in a recognized, defensible method or determined from applicable experimental data.
- 1.3.1.8** Sump screen flow resistance that is due to blockage by LOCA-generated debris or foreign material in the containment which is transported to the suction intake screens should be determined using Regulatory Position 1.3.4.
- 1.3.1.9** Calculation of available NPSH should be performed as a function of time until it is clear that the available NPSH will not decrease further.

1.3.2 Debris Sources and Generation

- 1.3.2.1** Consistent with the requirements of 10 CFR 50.46, debris generation should be calculated for a number of postulated LOCAs of different sizes, locations, and other properties sufficient to provide assurance that the most severe postulated LOCAs are calculated. The level of severity corresponding to each postulated break should be based on the potential head loss incurred across the sump screen. Some PWRs may need recirculation from the sump for licensing basis events other than LOCAs. Therefore, licensees should evaluate the licensing basis and include potential break locations in the main steam and main feedwater lines as well in determining the most limiting conditions for sump operation.
- 1.3.2.2** An acceptable method for estimating the amount of debris generated by a postulated LOCA is to use the zone of influence (ZOI). Examples of this approach are provided in NUREG/CR-6224 and Boiling Water Reactor Owners' Group (BWROG) Utility Resolution Guidance (NEDO-32686 and the staff's Safety Evaluation on the BWROG's

response to NRC Bulletin 96-03). A representation of the ZOI for commonly used insulation materials is shown in Figure 3.

- The size and shape of the ZOI should be supported by analysis or experiments for the break and potential debris. The size and shape of the ZOI should be consistent with the debris source (e.g., insulation, fire barrier materials, etc.) damage pressures, i.e., the ZOI should extend until the jet pressures decrease below the experimentally determined damage pressures appropriate for the debris source.
- The volume of debris contained within the ZOI should be used to estimate the amount of debris generated by a postulated break.
- The size distribution of debris created in the ZOI should be determined by analysis or experiments.
- The shock wave generated during the postulated pipe break and the subsequent jet should be the basis for estimating the amount of debris generated and the size or size distribution of the debris generated within the ZOI.

Certain types of material used in a small quantity inside the containment can, with adequate justification, be demonstrated to make a marginal contribution to the debris loading for the ECC sump. If debris generation and debris transport data have not been determined experimentally for such material, it may be grouped with another like material existing in large quantities. For example, a small quantity of fibrous filtering material may be grouped with a substantially large quantity of fibrous insulation debris, and the debris generation and transport data for the filter material need not be determined experimentally. However, such analyses are valid only if the small quantity of material treated in this manner does not have a significant effect when combined with other materials (e.g., a small quantity of calcium silicate combined with fibrous debris).

1.3.2.3 A sufficient number of breaks in each high-pressure system that relies on recirculation should be considered to reasonably bound variations in debris generation by the size, quantity, and type of debris. As a minimum, the following postulated break locations should be considered.

- Breaks in the reactor coolant system (e.g., hot leg, cold leg, pressurizer surge line) and, depending on the plant licensing basis, main steam and main feedwater lines with the largest amount of potential debris within the postulated ZOI,
- Large breaks with two or more different types of debris, including the breaks with the most variety of debris, within the expected ZOI,
- Breaks in areas with the most direct path to the sump,
- Medium and large breaks with the largest potential particulate debris to insulation ratio by weight, and

- Breaks that generate an amount of fibrous debris that, after its transport to the sump screen, could form a uniform thin bed that could subsequently filter sufficient particulate debris to create a relatively high head loss referred to as the 'thin-bed effect.' The minimum thickness of fibrous debris needed to form a thin bed has typically been estimated at 1/8 inch thick based on the nominal insulation density (NUREG/CR-6224).

1.3.2.4 All insulation (e.g., fibrous, calcium silicate, reflective metallic), painted surfaces, fire barrier materials, and fibrous, cloth, plastic, or particulate materials within the ZOI should be considered a debris source. Analytical models or experiments should be used to predict the size of the postulated debris. For breaks postulated in the vicinity of the pressure vessel, the potential for debris generation from the packing materials commonly used in the penetrations and the insulation installed on the pressure vessel should be considered. Particulate debris generated by pipe rupture jets stripping off paint or coatings and eroding concrete at the point of impact should also be considered.

1.3.2.5 The cleanliness of the containment during plant operation should be considered when estimating the amount and type of debris available to block the ECC sump screens. The potential for such material (e.g., thermal insulation other than piping insulation, ropes, fire hoses, wire ties, tape, ventilation system filters, permanent tags or stickers on plant equipment, rust flakes from unpainted steel surfaces, corrosion products, dust and dirt, latent individual fibers) to impact head loss across the ECC sump screens should also be considered.

1.3.2.6 In addition to debris generated by jet forces from the pipe rupture, debris created by the resulting containment environment (thermal and chemical) should be considered in the analyses. Examples of this type of debris would be disbondment of coatings in the form of chips and particulates or formation of chemical debris (precipitants) caused by chemical reactions in the pool.

1.3.2.7 Debris generation that is due to continued degradation of insulation and other debris when subjected to turbulence caused by cascading water flows from upper regions of the containments or near the break overflow region should be considered in the analyses.

1.3.3 Debris Transport

1.3.3.1 The calculation of debris quantities transported from debris sources to the sump screen should consider all modes of debris transport, including airborne debris transport, containment spray washdown debris transport, and containment sump pool debris transport. Consideration of the containment pool debris transport should include (1) debris transport during the fill-up phase, as well as during the recirculation phase, (2) the turbulence in the pool caused by the flow of water, water entering the pool from break overflow, and containment spray drainage, and (3) the buoyancy of the debris. Transport analyses of debris should consider: (1) debris that would float along the pool

surface, (2) debris that would remain suspended due to pool turbulence (e.g., individual fibers and fine particulates), and (3) debris that readily settles to the pool floor.

- 1.3.3.2** The debris transport analyses should consider each type of insulation (e.g., fibrous, calcium silicate, reflective metallic) and debris size (e.g., particulates, fibrous fine, large pieces of fibrous insulation). The analyses should also consider the potential for further decomposition of the debris as it is transported to the sump screen.
- 1.3.3.3** Bulk flow velocity from recirculation operations, LOCA-related hydrodynamic phenomena, and other hydrodynamic forces (e.g., local turbulence effects or pool mixing) should be considered for both debris transport and ECC sump screen velocity computations.
- 1.3.3.4** An acceptable analytical approach to predict debris transport within the sump pool is to use computational fluid dynamics (CFD) simulations in combination with the experimental debris transport data. Examples of this approach are provided in NUREG/CR-6772 and NUREG/CR-6773. Alternative methods for debris transport analyses are also acceptable, provided they are supported by adequate validation of analytical techniques using experimental data to ensure that the debris transport estimates are conservative with respect to the quantities and types of debris transported to the sump screen.
- 1.3.3.5** Curbs can be credited for removing heavier debris that has been shown analytically or experimentally to travel by sliding along the containment floor and that cannot be lifted off the floor within the calculated water velocity range.
- 1.3.3.6** If transported to the sump pool, all debris (e.g., fine fibrous, particulates) that would remain suspended due to pool turbulence should be considered to reach the sump screen.
- 1.3.3.7** The time to switch over to sump recirculation and the operation of containment spray should be considered in the evaluation of debris transport to the sump screen.
- 1.3.3.8** In lieu of performing airborne and containment spray washdown debris transport analyses, it could be assumed that all debris will be transported to the sump pool.

In lieu of performing sump pool debris transport analyses (Regulatory Position 1.3.3.4), it could be assumed that all debris entering the sump pool or originating in the sump will be considered transported to the sump screen when estimating screen debris bed head loss.

If it is credible in a plant that all drains leading to the containment sump could become completely blocked, or an inventory holdup in containment could happen together with debris loading on the sump screen, these situations could pose a worse impact on the recirculation sump performance than the assumed situations mentioned above. In this case, these situations should also be assessed.

- 1.3.3.9** The effects of floating or buoyant debris on the integrity of the sump screen and on subsequent head loss should be considered. For screens that are not fully submerged or are only shallowly submerged, floating debris could contribute to the debris bed head loss. The head loss due to floating or buoyant debris could be minimized by a design feature to keep buoyant debris from reaching the sump screen.
- 1.3.4 Debris Accumulation and Head Loss**
- 1.3.4.1** ECC sump screen blockage should be evaluated based on the amount of debris estimated using the assumptions and criteria described in Regulatory Position 1.3.2 and on the debris transported to the ECC sump per Regulatory Position 1.3.3. This volume of debris should be used to estimate the rate of accumulation of debris on the ECC sump screen.
- 1.3.4.2** Consideration of ECC sump screen submergence (full or partial) at the time of switchover to ECCS should be given in calculating the available (wetted) screen area. For plants in which containment heat removal pumps take suction from the ECC sump before switchover to the ECCS, the available NPSH for these pumps should consider the submergence of the sump screens at the time these pumps initiate suction from the ECC sump. Unless otherwise shown analytically or experimentally, debris should be assumed to be uniformly distributed over the available sump screen surface. Debris mass should be calculated based on the amount of debris estimated to reach the ECC sump screen. (See Revision 1 of NUREG-0897, NUREG/CR-3616, and NUREG/CR-6224.)
- 1.3.4.3** For fully submerged sump screens, the NPSH available to the ECC pumps should be determined using the conditions specified in the plant's licensing basis.
- 1.3.4.4** For partially submerged sumps, NPSH margin may not be the only failure criterion, as discussed in Appendix A. For partially submerged sumps, credit should only be given to the portion of the sump screen that is expected to be submerged, as a function of time. Pump failure should be assumed to occur when the head loss across the sump screen (including only the clean screen head loss and the debris bed head loss) is greater than one-half of the submerged screen height or NPSH margin.
- 1.3.4.5** Estimates of head loss caused by debris blockage should be developed from empirical data based on the sump screen design (e.g., surface area and geometry), postulated combinations of debris (i.e., amount, size distribution, type), and approach velocity. Because debris beds that form on sump screens can trap debris that would pass through an unobstructed sump screen opening, any head loss correlation should conservatively account for filtration of particulates by the debris bed, including particulates that would pass through an unobstructed sump screen.
- 1.3.4.6** Consistent with the requirements of 10 CFR 50.46, head loss should be calculated for the debris beds formed of different combinations of fibers and particulate mixtures (e.g.,

minimum uniform thin bed of fibers supporting a layer of particulate debris) based on assumptions and criteria described in Regulatory Positions 1.3.2 and 1.3.3.

2. BOILING WATER REACTORS

2.1 Features Needed To Minimize the Potential for Loss of NPSH

The suppression pool is the source of water for such functions as ECC and containment heat removal following a LOCA, in conjunction with the vents and downcomers between the drywell and the wetwell. It should combine the following features and capabilities to ensure the availability of the suppression pool for long-term cooling. The adequacy of the combinations of the features and capabilities should be evaluated using the criteria and assumptions in Regulatory Position 2.2.

2.1.1 Net Positive Suction Head of ECCS and Containment Heat Removal Pumps

2.1.1.1 ECC and containment heat removal systems should be designed so that adequate available NPSH is provided to the system pumps, assuming the maximum expected temperature of the pumped fluid and no increase in containment pressure from that present prior to the postulated LOCAs. (See Regulatory Position 2.1.1.2.)

2.1.1.2 For certain operating BWRs for which the design cannot be practicably altered, conformance with Regulatory Position 2.1.1.1 may not be possible. In these cases, no additional containment pressure should be included in the determination of available NPSH than is necessary to preclude pump cavitation. Calculation of available containment pressure should underestimate the expected containment pressure when determining available NPSH for this situation. Calculation of suppression pool water temperature should overestimate the expected temperature when determining available NPSH.

2.1.1.3 For certain operating BWRs for which the design cannot be practicably altered, if credit is taken for operation of an ECCS or containment heat removal pump in cavitation, prototypical pump tests should be performed along with post-test examination of the pump to demonstrate that pump performance will not be degraded and that the pump continues to meet all the performance criteria assumed in the safety analyses. The time period in the safety analyses during which the pump may be assumed to operate while cavitating should not be longer than the time for which the performance tests demonstrate the pump meets performance criteria.

2.1.1.4 The decay and residual heat produced following accident initiation should be included in the determination of the water temperature. The uncertainty in the determination of the decay heat should be included in this calculation. The residual heat should be calculated with margin.

- 2.1.1.5 The hot channel correction factor specified in ANSI/HI 1.1-1.5-1994 should not be used in determining the margin between the available and required NPSH for ECCS and containment heat removal system pumps.
- 2.1.1.6 The level of water in suppression pools should be the minimum value given in the technical specifications reduced by the drawdown due to suppression pool water in the drywell and the sprays.
- 2.1.1.7 Pipe and fitting resistance and the nominal screen resistance without blockage by debris should be calculated in a recognized, defensible method or determined from applicable experimental data.
- 2.1.1.8 Suction strainer screen flow resistance caused by blockage by LOCA-generated debris or foreign material in the containment that is transported to the suction intake screens should be determined using the methods in Regulatory Position 2.3.3.
- 2.1.1.9 Calculation of available NPSH should be performed as a function of time until it is clear that the available NPSH will not decrease further.

2.1.2 **Passive Strainer**

The inlet of pumps performing the above functions should be protected by a suction strainer placed upstream of the pumps; this is to prevent the ingestion of debris that may damage components or block restrictions in the systems served by the ECC pumps. The following items should be considered in the design and implementation of a passive strainer.

- 2.1.2.1 The suction strainer design (i.e., size and shape) should be chosen to avoid the loss of NPSH from debris blockage during the period that the ECCS is required to operate in order to maintain long-term cooling or maximize the time before loss of NPSH caused by debris blockage when used with an active mitigation system (see Regulatory Position 2.1.5).
- 2.1.2.2 The possibility of debris clogging flow restrictions downstream of the strainers should be assessed to ensure adequate long-term ECCS performance. The size of openings in the suppression pool suction strainers should be based on the minimum restrictions found in systems served by the suppression pool. The potential for long thin slivers passing axially through the strainer and then reorienting and clogging at any flow restriction downstream should be considered.

Consideration should be given to the buildup of debris at the following downstream locations: spray nozzle openings, throttle valves, coolant channel openings in the core fuel assemblies, fuel assembly inlet debris screens, ECCS pump seals, bearings, and impeller running clearances. If it is determined that a strainer with openings small enough to filter out particles of debris that are fine enough to cause damage to ECCS pump seals or bearings would be impractical, it is expected that modifications would be

made to ECCS pumps or ECCS pumps would be procured that can operate long term under the probable conditions.

- 2.1.2.3 ECC pump suction inlets should be designed to prevent degradation of pump performance through air ingestion and other adverse hydraulic effects (e.g., circulatory flow patterns, high intake head losses).
- 2.1.2.4 All drains from the upper regions of the containment should terminate in such a manner that direct streams of water, which may contain entrained debris, will not impinge on the suppression pool suction strainers.
- 2.1.2.5 The strength of the suction strainers should be adequate to protect the debris screen from missiles and other large debris. The strainers and the associated structural supports should be adequate to withstand loads imposed by missiles, debris accumulation, and hydrodynamic loads induced by suppression pool dynamics. To the extent practical, the strainers should be located outside the zone of influence of the vents, downcomers, or spargers to minimize hydrodynamic loads. The strainer design, vis-a-vis the hydrodynamic loads, should be validated analytically or experimentally.
- 2.1.2.6 The suction strainers should be designed to withstand the inertial and hydrodynamic effects that are due to vibratory motion of a safe shutdown earthquake (SSE) without loss of structural integrity.
- 2.1.2.7 Material for suction strainers should be selected to avoid degradation during periods of inactivity and operation and should have a low sensitivity to such adverse effects as stress-assisted corrosion that may be induced by coolant during LOCA conditions.

2.1.3 **Minimizing Debris**

The amount of potential debris (see Regulatory Position 2.3.1) that could clog the ECC suction strainers should be minimized.

- 2.1.3.1 Containment cleanliness programs should be instituted to clean the suppression pool on a regular basis, and plant procedures should be established for control and removal of foreign materials from the containment.
- 2.1.3.2 Debris interceptors in the drywell in the vicinity of the downcomers or vents may serve effectively in reducing debris transport to the suppression pool. In addition to meeting Regulatory Position 2.1.2, debris interceptors between the drywell and wetwell should not reduce the suppression capability of the containment.
- 2.1.3.3 Insulation types (e.g., fibrous and calcium silicate) that can be sources of debris that is known to more readily transport to the strainer and cause higher head losses should be avoided. Insulations (e.g., reflective metallic insulation) that transport less readily and cause less severe head losses once deposited onto the strainers should be used. If

insulation is replaced or otherwise removed during maintenance, abatement procedures should be established to avoid generating latent debris in the containment.

- 2.1.3.4** To minimize potential debris caused by chemical reaction of coolant with metals in the containment, exposure of bare metal surfaces (e.g., scaffolding) to spray impingement or immersion should be minimized either by removal or by using chemical-resistant protection (e.g., coatings or jackets).

2.1.4 Instrumentation

If relying on operator actions to mitigate the consequences of the accumulation of debris on the suction strainers, safety-related instrumentation that provides operators with an indication and audible warning of impending loss of NPSH for ECCS pumps should be available in the control room.

2.1.5 Active Strainers

An active component or system (see Appendix B) may be provided to prevent the accumulation of debris on a suction strainer or to mitigate the consequences of accumulation of debris on a suction strainer. An active system should be able to prevent debris that may block restrictions found in the systems served by the ECC pumps from entering the system. The operation of the active component or system should not adversely affect the operation of other ECC components or systems. The use of active strainers should be validated by adequate testing.

2.1.6 Inservice Inspection

Inservice inspection requirements should be established that include (1) inspection of the cleanliness of the suppression pool, (2) a visual examination for evidence of structural degradation or corrosion of the suction strainers and strainer system, and (3) an inspection of the wetwell and the drywell, including the vents, downcomers, and deflectors, for the identification and removal of debris or trash that could contribute to the blockage of suppression pool suction strainers. These inservice inspections should be performed on a regular basis at every refueling period downtime.

2.2 Evaluation of Alternative Water Sources

To demonstrate that a combination of the features and actions listed above are adequate to ensure long-term cooling and that the five criteria of 10 CFR 50.46(b) will be met following a LOCA, an evaluation using the guidance and assumptions in Regulatory Position 2.3 should be conducted. If a licensee is relying on operator actions to prevent the accumulation of debris on suction strainers or to mitigate the consequences of the accumulation of debris on the suction strainers, an evaluation should be performed to ensure that the operator has adequate indications, training, time, and system capabilities to perform the necessary actions. If not covered by plant-specific emergency operating procedure, procedures should be established to use alternative water sources. The valves needed to align the ECCS with an alternative water source should be periodically inspected and maintained.

2.3 Evaluation of Long-Term Recirculation Capability

During any evaluation of the susceptibility of a BWR to debris blockage, the considerations and events shown in Figures 4 and 5 should be addressed. The following techniques, assumptions, and guidance should be used in a deterministic evaluation to ensure that any implementation of a combination of the features and capabilities listed in Regulatory Position 2.1 are adequate to ensure the availability of a reliable water source for long-term recirculation after a LOCA. An assessment should be made of the susceptibility to debris blockage of the containment drainage flowpaths to the suppression pool, flow restrictions in the ECCS, and containment spray recirculation flowpaths downstream of the suction strainer to protect against degradation of long-term recirculation pumping capacity. Unless otherwise noted, the techniques, assumptions, and guidance listed below are applicable to an evaluation of passive and active strainers. The assumptions and guidance listed below can also be used to develop test conditions for suction strainers or strainer systems.

2.3.1 Debris Sources and Generation

2.3.1.1 Consistent with the requirements of 10 CFR 50.46, debris generation should be calculated for a number of postulated LOCAs of different sizes, locations, and other properties sufficient to provide assurance that the most severe postulated LOCAs are calculated.

2.3.1.2 An acceptable method for determining the shape of the zone of influence (ZOI) of a break is described in NUREG/CR-6224 and NEDO-32686. The volume contained within the ZOI should be used to estimate the amount of debris generated by a postulated break. The distance of the ZOI from the break should be supported by analysis or experiments for the break and potential debris. The shock wave generated during postulated pipe break and the subsequent jet should be the basis for estimating the amount of debris generated and the size or size distribution of the debris generated within the ZOI.

Certain types of material used in a small quantity inside the containment can, with adequate justification, be demonstrated to make a marginal contribution to the debris loading for the ECC sump. If debris generation and debris transport data have not been determined experimentally for such material, it may be grouped with another like material existing in large quantities. For example, a small quantity of fibrous filtering material may be grouped with a substantially larger quantity of fibrous insulation debris, and the debris generation and transport data for the filter material need not be determined experimentally. However, such analyses are valid only if the small quantity of material treated in this manner does not have a significant effect when combined with other materials (e.g., a small quantity of calcium silicate combined with fibrous debris).

2.3.1.3 All sources of fibrous materials in the containment such as fire protection materials, thermal insulation, or filters that are present during operation should be identified.

- 2.3.1.4** All insulation, painted surfaces, and fibrous, cloth, plastic, or particulate materials within the ZOI should be considered debris sources. Analytical models or experiments should be used to predict the size of the postulated debris.
- 2.3.1.5** A sufficient number of breaks in each high-pressure system that relies on recirculation should be considered to reasonably bound variations in debris generation by the size, quantity, and type of debris. As a minimum, the following postulated break locations should be considered.
- Breaks in the main steam, feedwater, and recirculation lines with the largest amount of potential debris within the postulated ZOI,
 - Large breaks with two or more different types of debris, including the breaks with the most variety of debris, within the expected ZOI,
 - Breaks in areas with the most direct path between the drywell and wetwell,
 - Medium and large breaks with the largest potential particulate debris to insulation ratio by weight, and
 - Breaks that generate an amount of fibrous debris that, after its transport to the suction strainer, could form a uniform thin bed that could subsequently filter sufficient particulate debris to create a relatively high head loss referred to as the ‘thin-bed effect.’ The minimum thickness of fibrous debris needed to form a thin bed has typically been estimated at 1/8 inch thick based on the nominal insulation density (NUREG/CR-6224).
- 2.3.1.6** The cleanliness of the suppression pool and containment during plant operation should be considered when estimating the amount and type of debris available to block the suction strainers. The potential for such material (e.g., thermal insulation other than piping insulation, ropes, fire hoses, wire ties, tape, ventilation system filters, permanent tags or stickers on plant equipment, rust flakes from unpainted steel surfaces, corrosion products, dust and dirt, latent individual fibers) to impact head loss across the suction strainer should also be considered.
- 2.3.1.7** The amount of particulates estimated to be in the pool prior to a LOCA should be considered to be the maximum amount of corrosion products (i.e., sludge) expected to be generated since the last time the pool was cleaned. The size distribution and amount of particulates should be based on plant samples.
- 2.3.1.8** In addition to debris generated by jet forces from the pipe rupture, debris created by the resulting containment environment (thermal and chemical) should be considered in the analyses. Examples of this type of debris would be disbondment of coatings in the form of chips and particulates or formation of chemical debris (precipitants) caused by chemical reactions in the pool.

2.3.2 Debris Transport

- 2.3.2.1** It should be assumed that all debris fragments smaller than the clearances in the gratings will be transported to the suppression pool during blowdown. Credit may be taken for filtration of larger pieces of debris by floor gratings and other interdicting structures present in a drywell (NEDO-32686 and NUREG/CR-6369). However, it should be assumed that a fraction of large fragments captured by the gratings would be eroded by the combined effects of cascading break overflow and the drywell spray flow. The fraction of the smaller debris generated and thus transported to the suppression pool during the blowdown, as well as the fraction of the larger debris that may be eroded during the washdown phase, should be determined analytically or experimentally.
- 2.3.2.2** It should be assumed that LOCA-induced phenomena (i.e., pool swell, chugging, condensation oscillations) will suspend all the debris assumed to be in the suppression pool at the onset of the LOCA.
- 2.3.2.3** The concentration of debris in the suppression pool should be calculated based on the amount of debris estimated to reach the suppression pool from the drywell and the amount of debris and foreign materials estimated to be in the suppression pool prior to a postulated break.
- 2.3.2.4** Credit should not be taken for debris settling until LOCA-induced turbulence in the suppression pool has ceased. The debris settling rate for the postulated debris should be validated analytically or experimentally.
- 2.3.2.5** Bulk suppression pool velocity from recirculation operations, LOCA-related hydrodynamic phenomena, and other hydrodynamic forces (e.g., local turbulence effects or pool mixing) should be considered for both debris transport and suction strainer velocity computations.

2.3.3 Strainer Blockage and Head Loss

- 2.3.3.1** Strainer blockage should be based on the amount of debris estimated using the assumptions and guidance described in Regulatory Position 2.3.1 and on the debris transported to the wetwell per Regulatory Position 2.3.2. This volume of debris, as well as other materials that could be present in the suppression pool prior to a LOCA, should be used to estimate the rate of accumulation of debris on the strainer surface.
- 2.3.3.2** The flow rate through the strainer should be used to estimate the rate of accumulation of debris on the strainer surface.
- 2.3.3.3** The suppression pool suction strainer area used in determining the approach velocity should conservatively account for blockage that may result. Unless otherwise shown analytically or experimentally, debris should be assumed to be uniformly distributed over the available suction strainer surface. Debris mass should be calculated based on

the amount of debris estimated to reach or to be in the suppression pool. (See Revision 1 of NUREG-0897, NUREG/CR-3616, and NUREG/CR-6224.)

- 2.3.3.4** The NPSH available to the ECC pumps should be determined using the conditions specified in the plant's licensing basis.
- 2.3.3.5** Estimates of head loss caused by debris blockage should be developed from empirical data based on the strainer design (e.g., surface area and geometry), postulated debris (i.e., amount, size distribution, type), and velocity. Any head loss correlation should conservatively account for filtration of particulates by the debris bed.
- 2.3.3.6** The performance characteristics of a passive or an active strainer should be supported by appropriate test data that addresses, at a minimum, (1) suppression pool hydrodynamic loads and (2) head loss performance.

D. IMPLEMENTATION

The purpose of this guide is to describe methods acceptable to the NRC staff for analyzing nuclear power plant sumps and suppression pools and for demonstrating their capability to perform long-term recirculation cooling following a loss-of-coolant accident in accordance with the requirements set forth in 10 CFR 50.46.

REFERENCES

ANSI/HI 1.1-1.5-1994, "Standard for Centrifugal Pumps for Nomenclature, Definitions, Application and Operation," American National Standards Institute, 1994.

Generic Letter 85-22, "Potential for Loss of Post-LOCA Recirculation Capability Due to Insulation Debris Blockage," USNRC, December 3, 1985.¹

Generic Letter 97-04, "Assurance of Sufficient Net Positive Suction Head for Emergency Core Cooling and Containment Heat Removal Pumps," USNRC, October 7, 1997.¹

Generic Letter 98-04, "Potential for Degradation of the Emergency Core Cooling System and the Containment Spray System after a Loss-of Coolant Accident Because of Construction and Protective Coating Deficiencies and Foreign Material in Containment," USNRC, July 14, 1998.¹

NEDO-32686, "Utility Resolution Guidance for ECCS Suction Strainer Blockage," Boiling Water Reactor Owners Group Topical Report, General Electric, November 1996.¹

NRC Bulletin No. 93-02, "Debris Plugging of Emergency Core Cooling Suction Strainers," USNRC, May 11, 1993.¹

NRC Bulletin No. 93-02, Supplement 1, "Debris Plugging of Emergency Core Cooling Suction Strainers," USNRC, February 18, 1994.¹

NRC Bulletin No. 95-02, "Unexpected Clogging of a Residual Heat Removal Pump Strainer While Operating in Suppression Pool Cooling Mode," USNRC, October 17, 1995.¹

NRC Bulletin No. 96-03, "Potential Plugging of Emergency Core Cooling Suction Strainers by Debris in Boiling Water Reactors," USNRC, May 6, 1996.¹

NRC Bulletin No. 2003-01, "Potential Impact of Debris Blockage on Emergency Sump Recirculation at Pressurized-Water Reactors," USNRC, June 9, 2003.¹

NRC Information Notice 94-57, "Debris in Containment and the Residual Heat Removal System," USNRC, August 12, 1994.¹

NRC Information Notice 95-06, "Potential Blockage of Safety-Related Strainers by Material Brought Inside Containment," USNRC, January 25, 1995.¹

NRC Information Notice 95-47, "Unexpected Opening of a Safety/Relief Valve and Complications Involving Suppression Pool Cooling Strainer Blockage," USNRC, October 4, 1995.¹

¹ Copies are available for inspection or copying for a fee from the NRC Public Document Room at 11555 Rockville Pike, Rockville, MD; the PDR's mailing address is USNRC PDR, Washington, DC 20555; telephone (301)415-4737 or 1-(800)397-4209; fax (301)415-3548; e-mail <PDR@NRC.GOV>. Copies of most are also available electronically on NRC's web page, www.nrc.gov, under Document Collections, Generic Communications.

NUREG-0897, A.W. Serkiz, "Containment Emergency Sump Performance (Technical Findings Related to Unresolved Safety Issue A-43)," Revision 1, USNRC, October 1985.²

NUREG/CR-2758, G.G. Weigand et al., "A Parametric Study of Containment Emergency Sump Performance" (SAND82-0624), USNRC, July 1982.²

NUREG/CR-2759, M.S. Krein et al., "A Parametric Study of Containment Emergency Sump Performance: Results of Vertical Outlet Sump Tests" (SAND82-7062), USNRC, October 1982.²

NUREG/CR-2760, M. Padmanabhan and G.E. Hecker, "Assessment of Scale Effects on Vortexing, Swirl, and Inlet Losses in Large Scale Sump Models" (ARL-48-82), USNRC, June 1982.²

NUREG/CR-2761, M. Padmanabhan, "Results of Vortex Suppressor Tests, Single Outlet Sump Tests, and Miscellaneous Sensitivity Tests" (SAND82-7065), USNRC, September 1982.²

NUREG/CR-2772, M. Padmanabhan, "Hydraulic Performance of Pump Suction Inlets for Emergency Core Cooling Systems in Boiling Water Reactors" (ARL-398A), USNRC, June 1982.²

NUREG/CR-2791, J. Wysocki and R. Kolbe, "Methodology for Evaluation of Insulation Debris Effects" (SAND82-7067), USNRC, September 1982.²

NUREG/CR-2792, P.S. Kammath, T.J. Tantillo, W.L. Swift, "An Assessment of Residual Heat Removal and Containment Spray Pump Performance Under Air and Debris Ingesting Conditions" (CREARE TM-825), USNRC, September 1982.²

NUREG/CR-2982, D.N. Brocard, "Buoyancy, Transport, and Head Loss of Fibrous Reactor Insulation" (SAND82-7205), Revision 1, USNRC, July 1983.²

NUREG/CR-3170, W.W. Durgin and J. Noreika, "The Susceptibility of Fibrous Insulation Pillows to Debris Formation Under Exposure to Energetic Jet Flows" (SAND83-7008), USNRC, March 1983.²

NUREG/CR-3394, J.J. Wysocki, "Probabilistic Assessment of Recirculation Sump Blockage Due to Loss-of-Coolant Accidents," Volumes 1 and 2 (SAND83-7116), USNRC, July 1983.²

NUREG/CR-3616, D.N. Brocard, "Transport and Screen Blockage Characteristics of Reflective Metallic Insulation Materials" (SAND83-7471), USNRC, January 1984.²

NUREG/CR-6224, G. Zigler et al., "Parametric Study of the Potential for BWR ECCS Strainer Blockage Due to LOCA Generated Debris" (SEA No. 93-554-06-A:1), USNRC, October 1995.²

² Copies are available at current rates from the U.S. Government Printing Office, P.O. Box 37082, Washington, DC 20402-9328 (telephone (202)512-1800); or from the National Technical Information Service by writing NTIS at 5285 Port Royal Road, Springfield, VA 22161; telephone (703)487-4650; <<http://www.ntis.gov/ordernow>>. Copies are available for inspection or copying for a fee from the NRC Public Document Room at 11555 Rockville Pike, Rockville, MD; the PDR's mailing address is USNRC PDR, Washington, DC 20555; telephone (301)415-4737 or (800)397-4209; fax (301)415-3548; email is PDR@NRC.GOV.

NUREG/CR-6369, "Drywell Debris Transport Study," USNRC, October 1999.²

NUREG/CR-6762, "GSI-191: Technical Assessment: Parametric Evaluations for Pressurized Water Reactor Recirculation Sump Performance" (Report LA-UR-01-4083, Rev. 1 by LANL), Volumes 1-4, USNRC, August 2002.²

NUREG/CR-6772, "GSI-191: Separate-Effects Characterization of Debris Transport in Water," USNRC, August 2002.²

NUREG/CR-6773, "GSI-191: Integrated Debris Transport Tests in Water Using Simulated Containment Floor Geometries," USNRC, December 2002.²

NUREG/CR-6808, "Knowledge Base for the Effect of Debris on Pressurized Water Reactor Emergency Core Cooling Sump Performance," USNRC, February 2003.²

Regulatory Guide 1.1, "Net Positive Suction Head for Emergency Core Cooling and Containment Heat Removal System Pumps," USNRC (U.S. Atomic Energy Commission), November 2, 1970.³

Safety Evaluation by the Office of Nuclear Reactor Regulation Related to NRC Bulletin 96-03, Boiling Water Reactor Owners Group Topical Report NEDO-32686, "Utility Resolution Guidance for ECCS Suction Strainer Blockage," August 20, 1998. (Electronically available at <http://nrr10/projects/ser/1998/m96920.htm> .)

³ Requests for single copies of draft or active regulatory guides (which may be reproduced) or for placement on an automatic distribution list for single copies of future draft guides in specific divisions should be made in writing to the U.S. Nuclear Regulatory Commission, Washington, DC 20555, Attention: Reproduction and Distribution Services Section, or by fax to (301)415-2289; email <DISTRIBUTION@NRC.GOV>. Copies are available for inspection or copying for a fee from the NRC Public Document Room at 11555 Rockville Pike (first floor), Rockville, MD; the PDR's mailing address is USNRC PDR, Washington, DC 20555; telephone (301)415-4737 or 1-(800)397-4209; fax (301)415-3548; e-mail <PDR@NRC.GOV>.

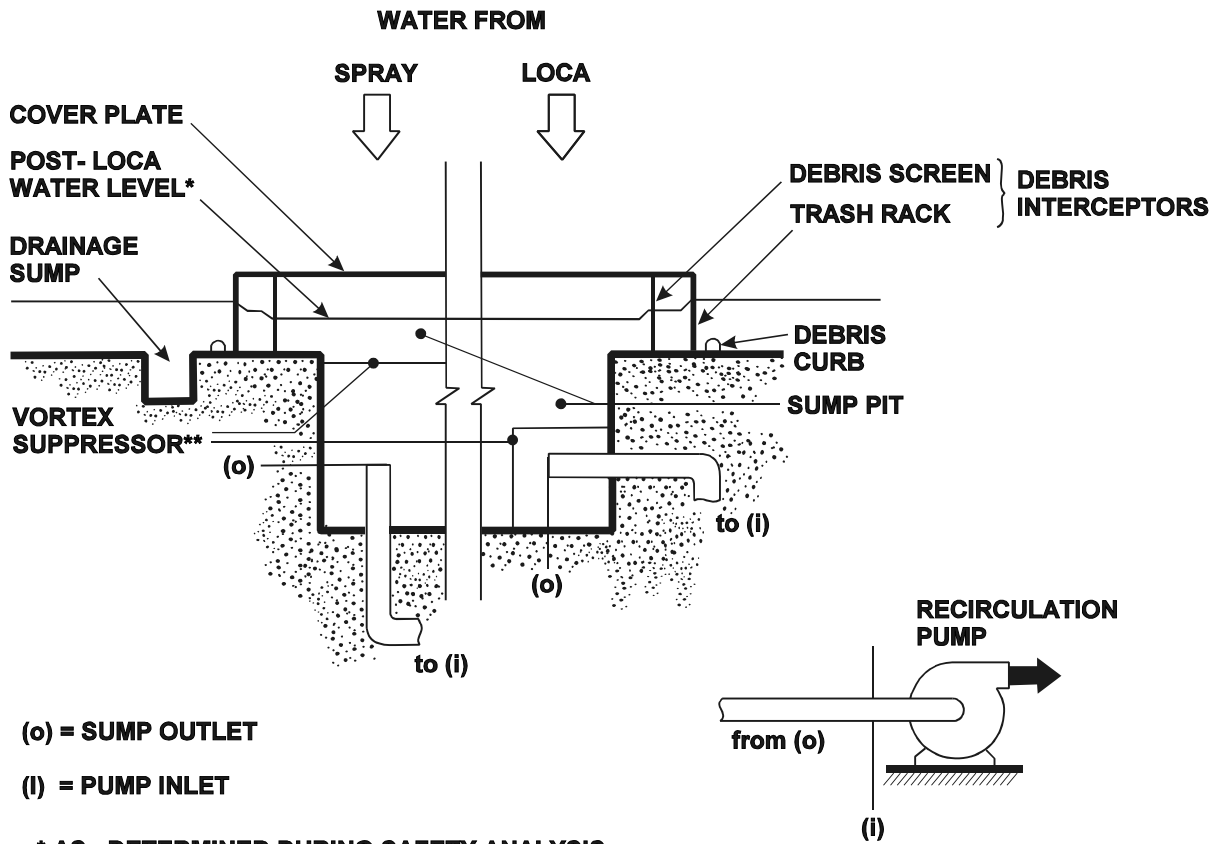

(o) = SUMP OUTLET

(i) = PUMP INLET

*** AS DETERMINED DURING SAFETY ANALYSIS**

**** CUBIC HORIZONTAL SUPPRESSOR MAY BE USED WITH EITHER SUMP OUTLET**

Note: Variations in Sump Features (e.g., Debris screen orientation and submergence level) exist, but not shown.

Figure 1. Conceptual Features of a PWR ECCS Recirculation Sump

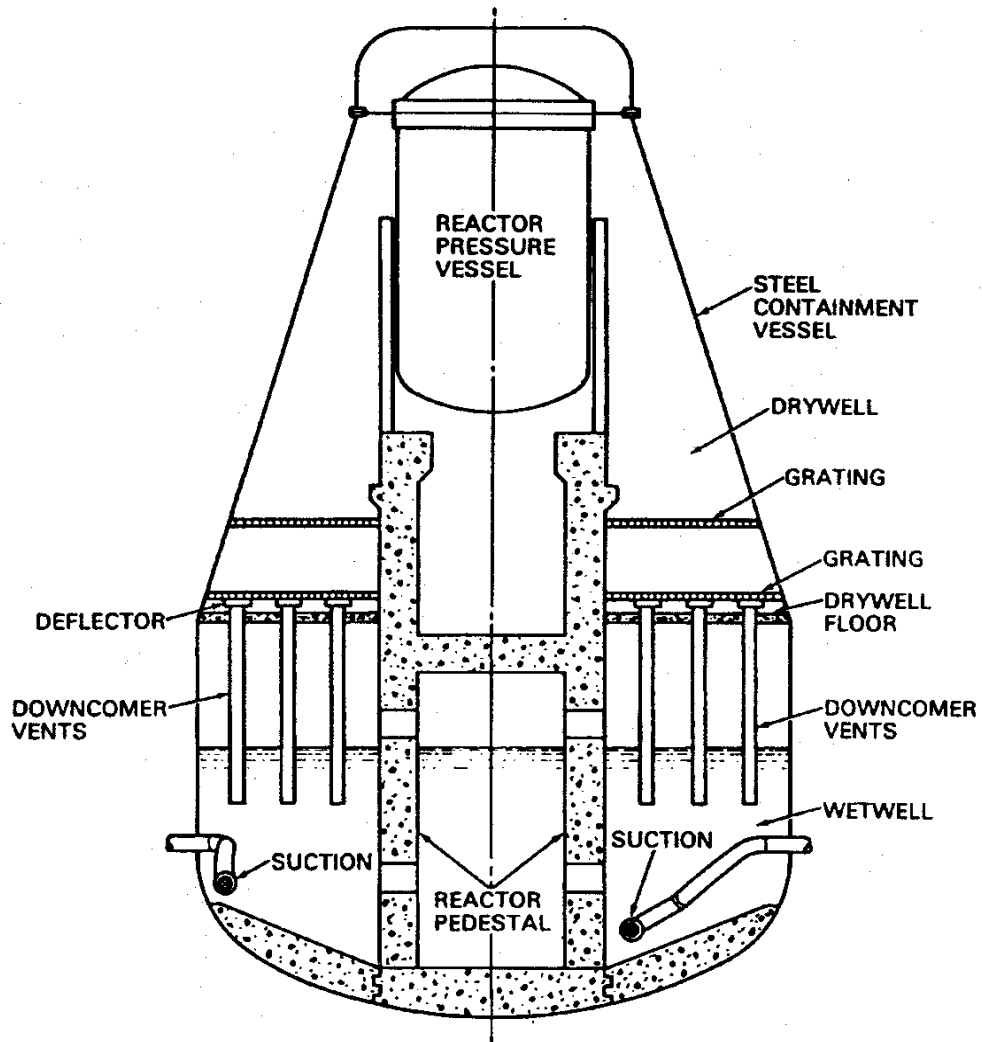

Note: Variations in suppression pool features (e.g., number, design and location of suction screen and down comer vents) exist but are not shown.

Figure 2: Conceptual Features of a BWR Containment

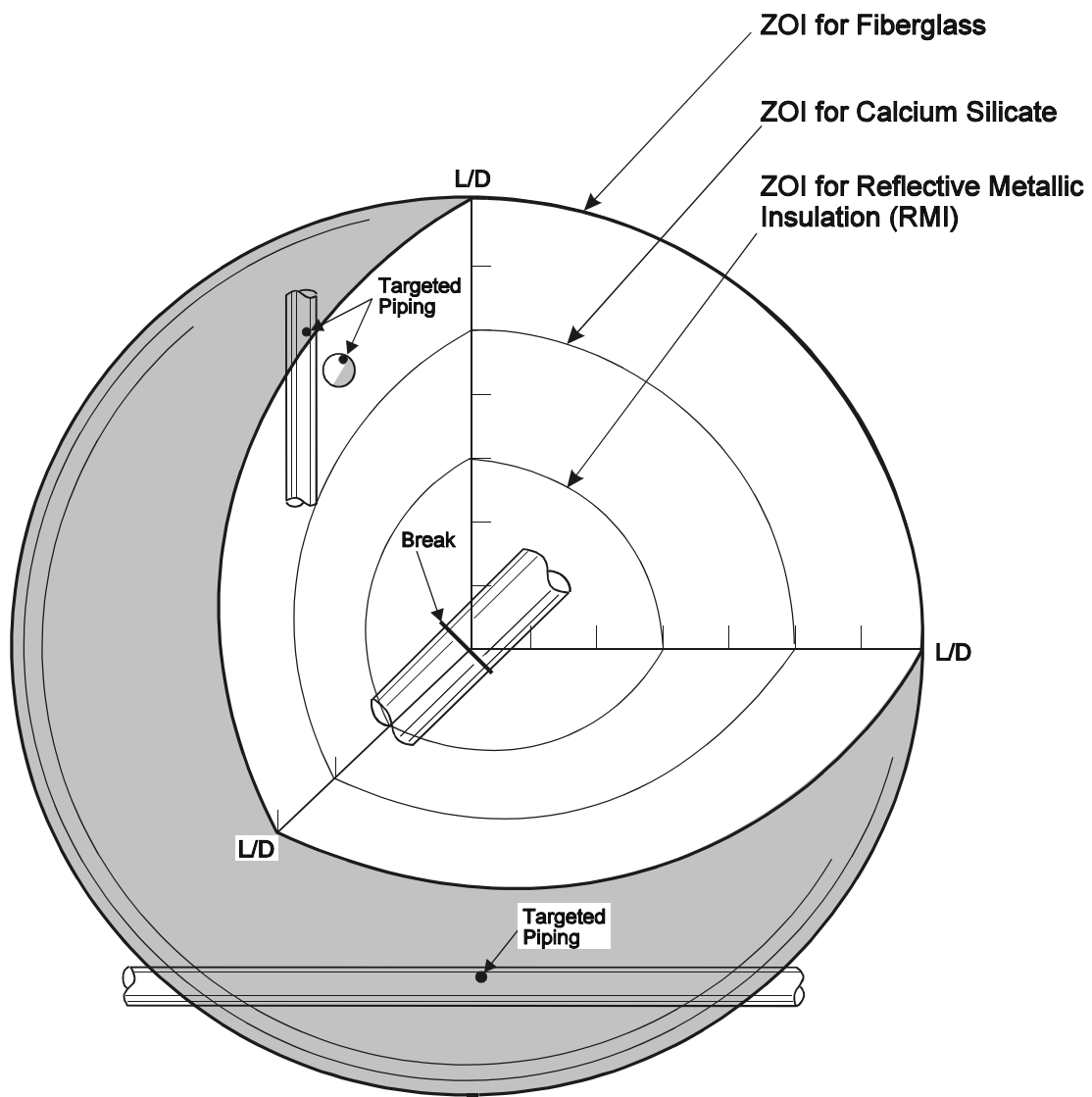

Note:
 L = Distance from break to target
 D = Diameter of broken pipe

Figure 3. Zone of Influence (ZOI)

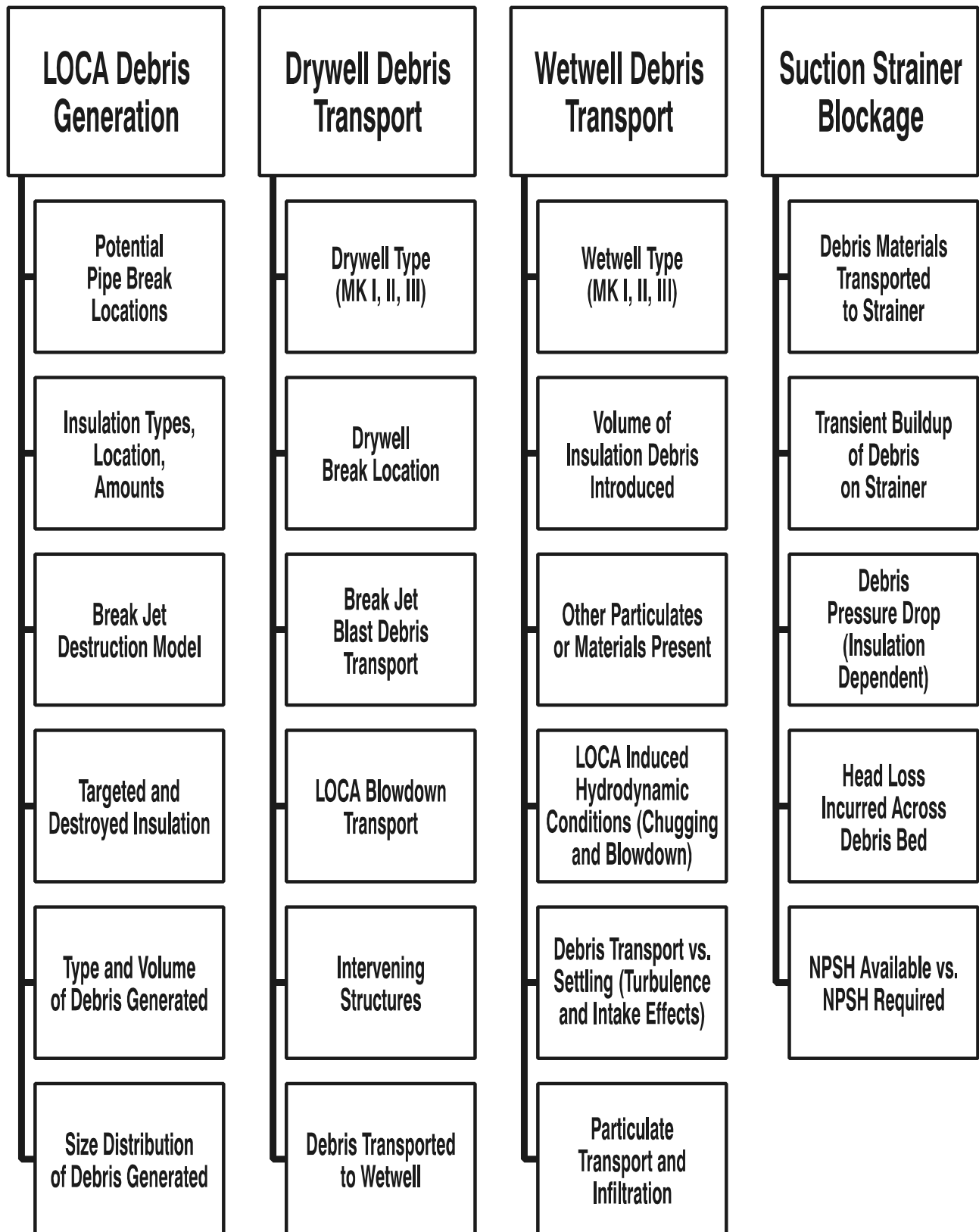

Figure 4. Debris Blockage Considerations for BWR LOCA Sequences

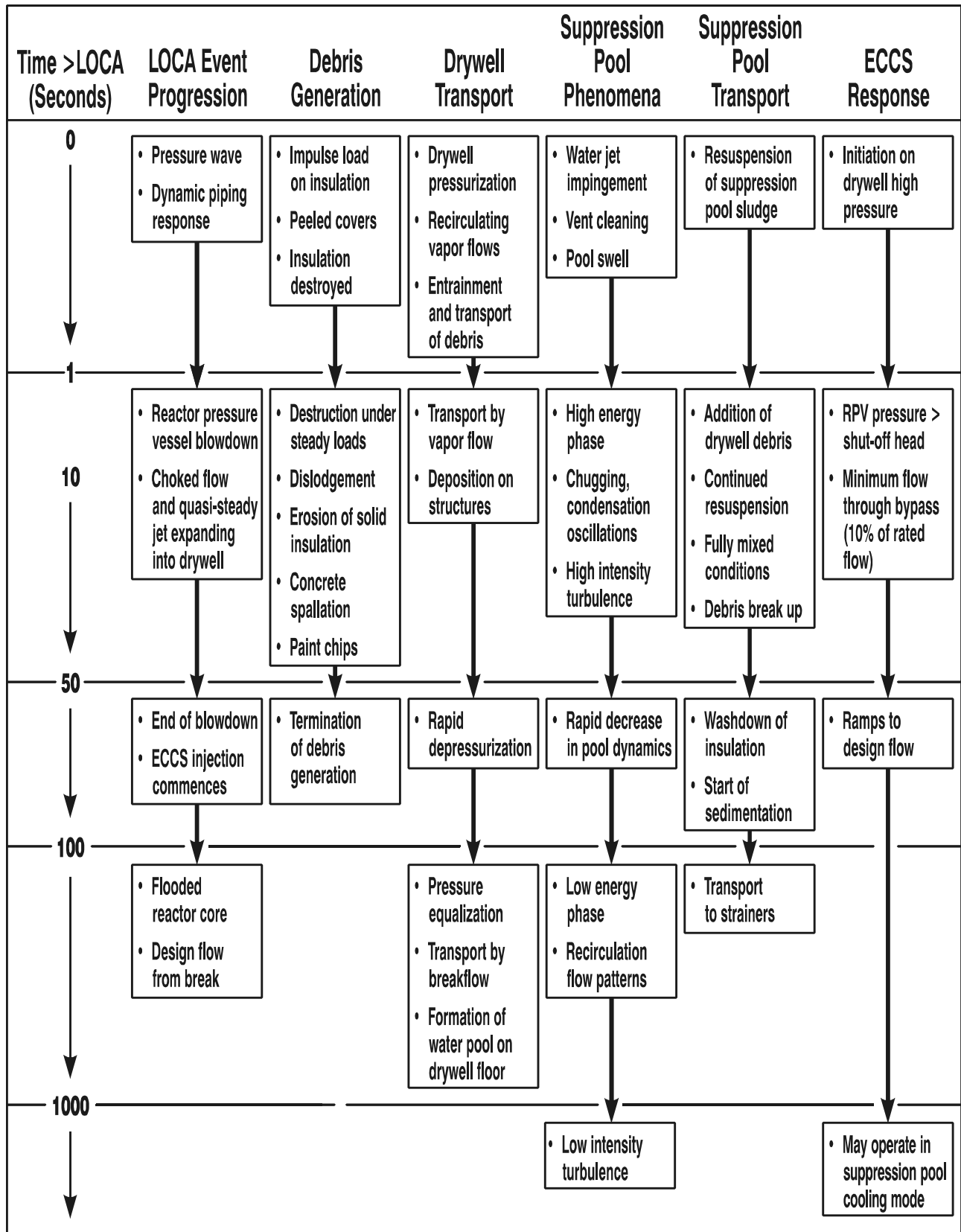

Figure 5. Events That May Effect Debris Blockage for BWR LOCA Sequences

APPENDIX A

GUIDELINES FOR REVIEW OF WATER SOURCES FOR EMERGENCY CORE COOLING

Water sources for long-term recirculation should be evaluated under possible post-LOCA conditions to determine the adequacy of their design for providing long-term recirculation. Technical evaluations can be subdivided into (1) sump hydraulic performance, (2) LOCA-induced debris effects, and (3) pump performance under adverse conditions. Specific considerations within these categories, and the combination thereof, are shown in Figure A-1. The final acceptance criterion is that adequate NPSH margin exists at the pump inlet under all postulated post-LOCA conditions.

SUMP HYDRAULIC PERFORMANCE

Sump hydraulic performance (with respect to air ingestion potential) can be evaluated on the basis of submergence level (or water depth above the PWR sump or BWR suction strainer outlets) and necessary pumping capacity (or pump inlet velocity). The water depth above the pipe centerlines and the inlet pipe velocity (U) can be expressed non-dimensionally as the Froude number:

$$\text{Froude number} = \frac{U}{\sqrt{gs}}$$

where g is the acceleration due to gravity. Extensive experimental results have shown that the hydraulic performance of ECC sumps (particularly the potential for air ingestion) is a strong function of the Froude number. Other nondimensional parameters (e.g., Reynolds number and Weber number) are of secondary importance.

Sump hydraulic performance can be divided into three performance categories:

1. Zero air ingestion, for which vortex suppressors or increases in the required NPSH above that from the pump manufacturer's curves are not needed.
2. Air ingestion of 2% or less, a conservative level at which degradation of pumping capability is not expected based on an increase of the required NPSH.
3. Vortex suppressors to reduce air ingestion effects to zero.

For PWRs, zero air ingestion can be ensured by use of the design guidance set forth in Table A-1. Determination of those designs having ingestion levels of 2% or less can be obtained using correlations given in Table A-2 and the attendant sump geometric envelope. Geometric and screen guidelines for PWRs are contained in Tables A-3.1, A-3.2, A-4, and A-5. Table A-6 presents design guidelines for vortex suppressors that have shown the capability to reduce air ingestion to zero. These guidelines (Tables A-1 through A-6) were developed from extensive hydraulic tests on full-scale sumps and provide a rapid means of assessing sump hydraulic performance. If the PWR

sump design deviates significantly from the bounding values of design parameters noted, similar performance data should be obtained for verification of adequate sump hydraulic performance.

For BWRs, full-scale tests of suppression pool suction strainer screen outlet designs for recirculation pumps have shown that air ingestion is zero for Froude numbers less than 0.8 with a minimum submergence of 6 feet, and operation up to a Froude number 1.0 with the same minimum submergence may be possible before air ingestion levels of 2% may occur (Revision 1 of NUREG-0897 and NUREG-2772).

LOCA-INDUCED DEBRIS EFFECTS

Assessment of LOCA debris generation and the determination of possible debris interceptor blockage is complex. The evaluation of this safety question is dependent on the types and quantities of insulation employed, the location of such insulation materials within containment and with respect to the sump or suppression pool strainer location, the estimation of quantities of debris generated by a pipe break, and the migration of such debris to the interceptors. Thus blockage estimates (i.e., generation, transport, and head loss) are specific to the insulation material, the piping layout, and the plant design.

Since break jet forces are the dominant debris generator, the predicted jet envelope will determine the quantities and types of insulation debris. Figure A-2 provides a conceptual three-region model that has been developed from analytical and experimental considerations as identified in Revision 1 of NUREG-0897 and NUREG/CR-6224. The destructive results (e.g., volume of insulation and other debris generated, size of debris) of the break jet forces will be considerably different for different types of insulation (Figure A-2), different types of installation methods, and distance from the break. Region I represents a total destruction zone; Region II represents a region where high levels of damage are possible depending on insulation type, whether encapsulation is employed, methods of attachment, etc.; and Region III represents a region where dislodgement of insulation in whole, or as-fabricated, segments is likely to occur. NUREG-0897 and NUREG/CR-6224 provide a more detailed discussion of these considerations. NUREG-0897, NUREG/CR-6224, NUREG/CR-2982, NUREG/CR-3170, NUREG/CR-3394, NUREG/CR-3616, NUREG/CR-6772, and NUREG/CR-6773 provide more detailed information relevant to assessing debris generation and transport.

PUMP PERFORMANCE UNDER ADVERSE CONDITIONS

The pump industry historically has determined required NPSH for pumps on the basis of a percentage degradation in pumping capacity. The percentage has at times been arbitrary, but generally is in the range of 1% to 3%. A 2% limit on allowed air ingestion is recommended since higher levels have been shown to initiate degradation of pumping capacity.

The 2% by volume limit on sump air ingestion and the NPSH criteria are applied independently. However, air ingestion levels less than 2% can also affect NPSH margin. If air ingestion is indicated, correct the required NPSH from the pump curves by the relationship:

$$\text{NPSH}_{\text{required}(\alpha_p < 2\%)} = \text{NPSH}_{\text{required}(\text{liquid})} \times \beta$$

where $\beta = 1 + 0.50\alpha_p$ and α_p is the air ingestion rate (in percent by volume) at the pump inlet flange.

COMBINED EFFECTS

As shown in Figure A-1, three interdependent effects (i.e., sump or suction strainer performance, debris generation and transport, and pump operation under adverse conditions) warrant evaluation for determining long-term recirculation capability (i.e., loss of NPSH margin).

CRITERIA FOR EVALUATING SUMP FAILURE

The sump failure criterion depends on sump submergence and may be pump or system dependent. Figures A-3(a) and A-3(b) illustrate the two basic sump configurations of fully and partially submerged screens. Although only vertical sump configurations are shown here, the same designations are applicable to other screen designs. The key distinction between the fully and partially submerged configurations is that partially submerged screens allow equal pressure above both the pit and the pool, which are potentially separated by a debris bed. Fully submerged screens have a complete seal of water between the pump inlet and the containment atmosphere along all water paths passing through the sump screen. The effect of this difference in evaluation of the sump failure criterion is described below.

Fully Submerged Sump Screens

Figure A-3(a) presents a schematic of a fully submerged sump. The most likely mode of failure for sumps in this configuration is due to cavitation within the pump housing when head loss caused by debris accumulation exceeds the $\text{NPSH}_{\text{Margin}}^*$. For this set of plants (in which sump screens are fully submerged at the time of switchover), the onset of cavitation is determined by comparing plant $\text{NPSH}_{\text{Margin}}$, which is part of the plant's licensing basis, with the screen head loss calculated in the plant evaluations performed per Regulatory Position 1.3. For this case, therefore, the sump failure criterion is assumed to be reached when

$$\text{Head Loss Across the Debris Bed} \geq \text{NPSH}_{\text{Margin}}$$

Note that cavitation could occur in one pump housing while a different pump with a different NPSH margin may not have cavitation. Only in certain conditions (Regulatory Position 1.3.1.3) may credit be taken for continued operation under cavitating conditions, which could relax the above sump failure criterion for a brief period and provide an opportunity for recovery action.

* $\text{NPSH}_{\text{Margin}}$ is the amount by which NPSHA exceeds NPSHR. This definition is given in ANSI/HI 1.1-1.5 1994, "American National Standard for Centrifugal Pumps for Nomenclature, Definitions, Application and Operation," Section 1.3.3.1.16.2, "NPSH Margin Considerations."

The same standard, in Section 1.3.3.1.16, defines NPSHA and NPSHR.

- Net positive suction head available (NPSHA) is the total suction head of liquid absolute, determined at the first stage impeller datum, less the absolute vapor pressure of the liquid.
- Net positive suction head required (NPSHR) is the amount of suction head, over vapor pressure, required to prevent more than 3% loss in total head of the first stage of the pump at a specific capacity.

The head loss due to debris is not included in the definition of NPSHA. The value of the head loss due to debris is compared to the value of $\text{NPSH}_{\text{Margin}}$ in order to determine whether pump cavitation will occur.

Partially Submerged Sump Screens

Figure A-3(b) presents a schematic of a partially submerged sump. Failure can occur for sumps in this configuration in one of two ways: by pump cavitation as explained above or when head loss caused by debris buildup prevents sufficient water from entering the sump. This flow imbalance occurs when water infiltration through a debris bed on the screen can no longer satisfy the volumetric demands of the pump or pumps taking suction from the sump. Because the pit and the pool are at equal atmospheric overpressure, the only force available to move water through a debris bed is the static pressure head in the pool. Numeric simulations confirm that an effective head loss across a debris bed approximately equal to half the submerged screen height is sufficient to prevent adequate water flow, i.e., the force available to move water through the debris bed is approximately the average between the gravitational head at the full depth of the pool and zero head at the pool surface. For all partially submerged sump screens, the sump failure criterion is assumed to be reached when

$$\text{Head Loss Across the Debris Bed} \geq \text{NPSH}_{\text{Margin}} \quad \text{or} \quad \geq \frac{1}{2} \text{ of submerged screen height}$$

When this criterion is met, the water level on the downstream side of the screen would drop rapidly and all pumps taking suction from the sump would have insufficient flow for continued operation.

After switchover to ECCS recirculation, the sump configuration would likely change from partially submerged to fully submerged. This can occur for a number of reasons, including accumulation of containment-spray water, continued melting of ice-condenser reservoirs, and continued addition of the refueling water storage tank (RWST) inventory to the containment pool. As the pool depth changes during recirculation, the “wetted area” (or submerged area) of the sump screens can also change. The wetted area of the screen determines the average approach velocity of water that may carry debris, the accumulation of debris on the screen and subsequent head loss, and the gravitational head of the pool across the screen. The sump water level should be calculated as a function of time and a conservative assessment made of debris transport and accumulation on the sump screen. For systems such as the recirculation containment spray that could initiate suction from the recirculation sumps before ECCS switchover, the sump water level applicable at that time should be calculated.

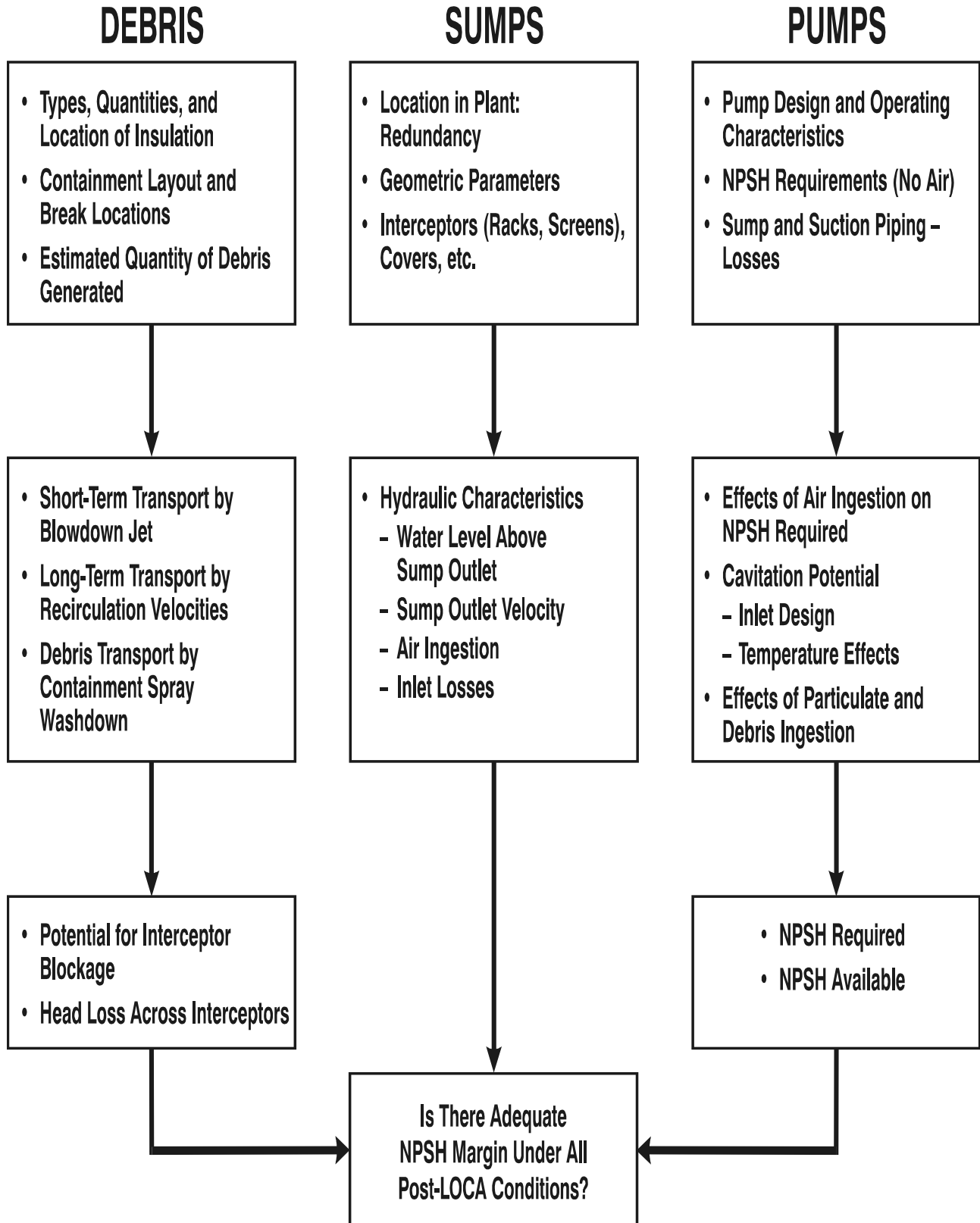

Figure A-1. Technical Considerations Relevant to PWR ECC Sump Performance

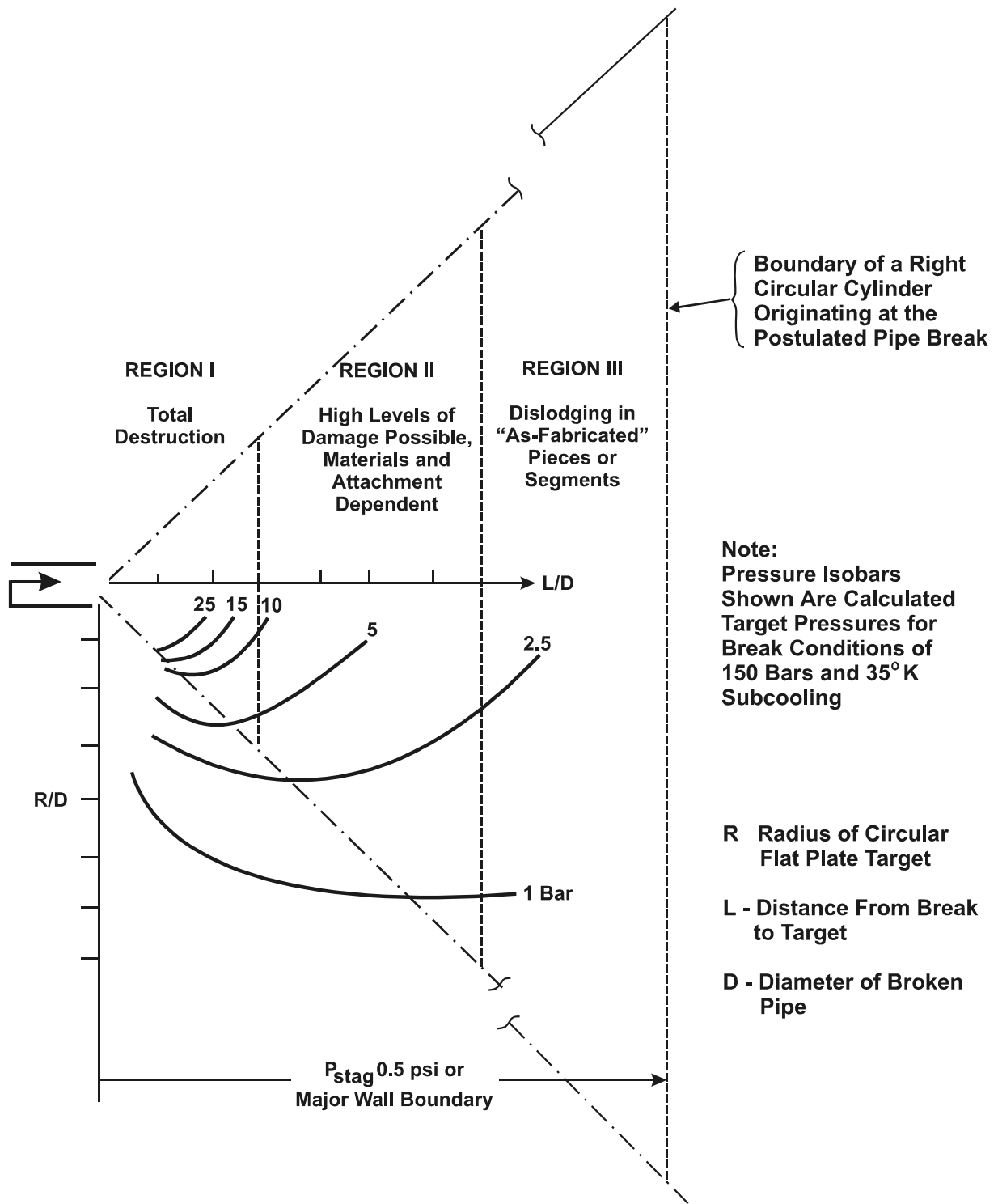
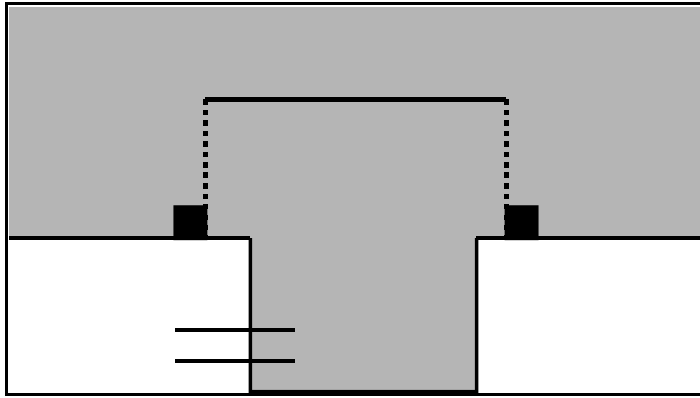
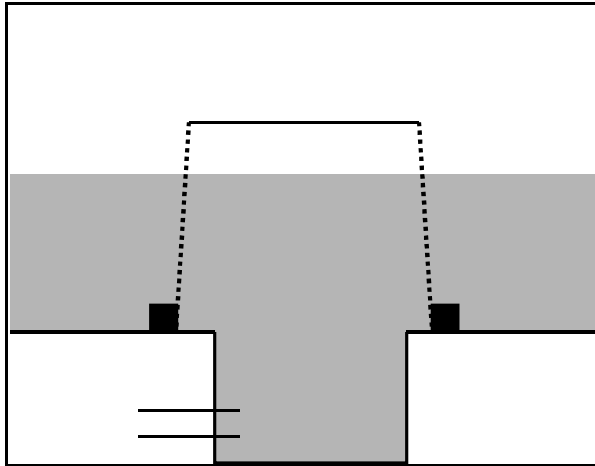

Figure A-2. Conceptual Multiple Region Insulation Debris Model



(a) Fully submerged screen configuration showing solid water from pump inlet to containment atmosphere.



(b) Partially submerged screen configuration showing containment atmosphere over both the external pool and the internal sump pit with water on lower portion of screen.

Figure A-3 Sump Screen Schematics

TABLE A-1

PWR HYDRAULIC DESIGN GUIDELINES FOR ZERO AIR INGESTION

Item	Horizontal Outlets	Vertical Outlets
Minimum Submergence, s (ft)	9	9
	(m) 2.7	2.7
Maximum Froude Number, Fr	0.25	0.25
Maximum Pipe Velocity, U (ft/s)	4	4
	(m/s) 1.2	1.2

NOTE: These guidelines were established using experimental results from NUREG/CR-2772, NUREG/CR-6224, and NUREG/CR-2982 and are based on sumps having a right rectangular shape.

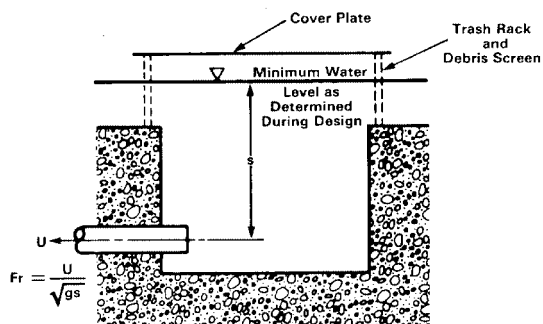

TABLE A-2

PWR HYDRAULIC DESIGN GUIDELINES FOR AIR INGESTION <2%

Air ingestion (α) is empirically calculated as

$$\alpha = \alpha_0 + (\alpha_1 \times Fr)$$
 where α_0 and α_1 are coefficients derived from test results as given in the table below

Item	Horizontal Outlets		Vertical Outlets	
	Dual	Single	Dual	Single
Coefficient α_0	-2.47	-4.75	-4.75	-9.14
Coefficient α_1	9.38	18.04	18.69	35.95
Minimum Submergence, s(ft)	7.5	8.0	7.5	10.0
(m)	2.3	2.4	2.3	3.1
Maximum Froude Number, Fr	0.5	0.4	0.4	0.3
Maximum Pipe Velocity, U(ft/s)	7.0	6.5	6.0	5.5
(m/s)	2.1	2.0	1.8	1.7
Maximum Screen Face Velocity (blocked and minimum submergence) (ft/s)	3.0	3.0	3.0	3.0
(m/s)	0.9	0.9	0.9	0.9
Maximum Approach Flow Velocity (ft/s)	0.36	0.36	0.3	0.36
(m/s)	0.11	0.11	0.11	0.11
Maximum Sump Outlet Coefficient, C_L	1.2	1.2	1.2	1.2

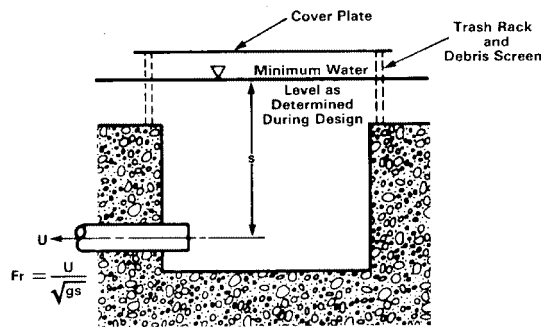

Table A-3.1

PWR GEOMETRIC DESIGN ENVELOP GUIDELINES FOR HORIZONTAL SUCTION OUTLETS

Sump Outlet	Sump Outlet Position*					
	e_y/d	$(B - e_y)/d$	c/d	b/d	f/d	e_x/d
Dual	>1	>3	>1.5	>1	>4	>1.5
Single					-	

* Preferred location.

Note: Dimensions are always measured to pipe centerline

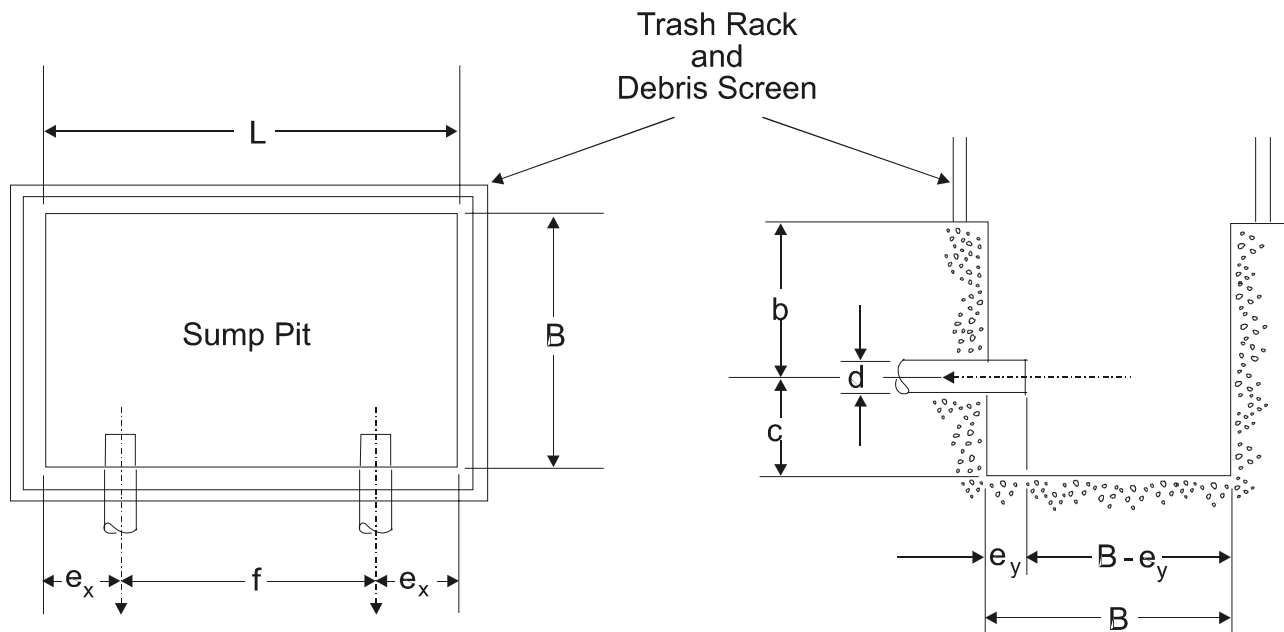

Table A-3.2

PWR GEOMETRIC DESIGN ENVELOP GUIDELINES FOR VERTICAL SUCTION OUTLETS

Sump Outlet	Sump Outlet Position*					
	e_y/d	$(B-e_y)/d$	c/d	b/d	f/d	e_x/d
Dual	>1	>1	>0	>1	>4	>1.5
Single	>1	>1	>1.5	>1	-	>1.5

* Preferred location.

Note: Dimensions are always measured to pipe centerline

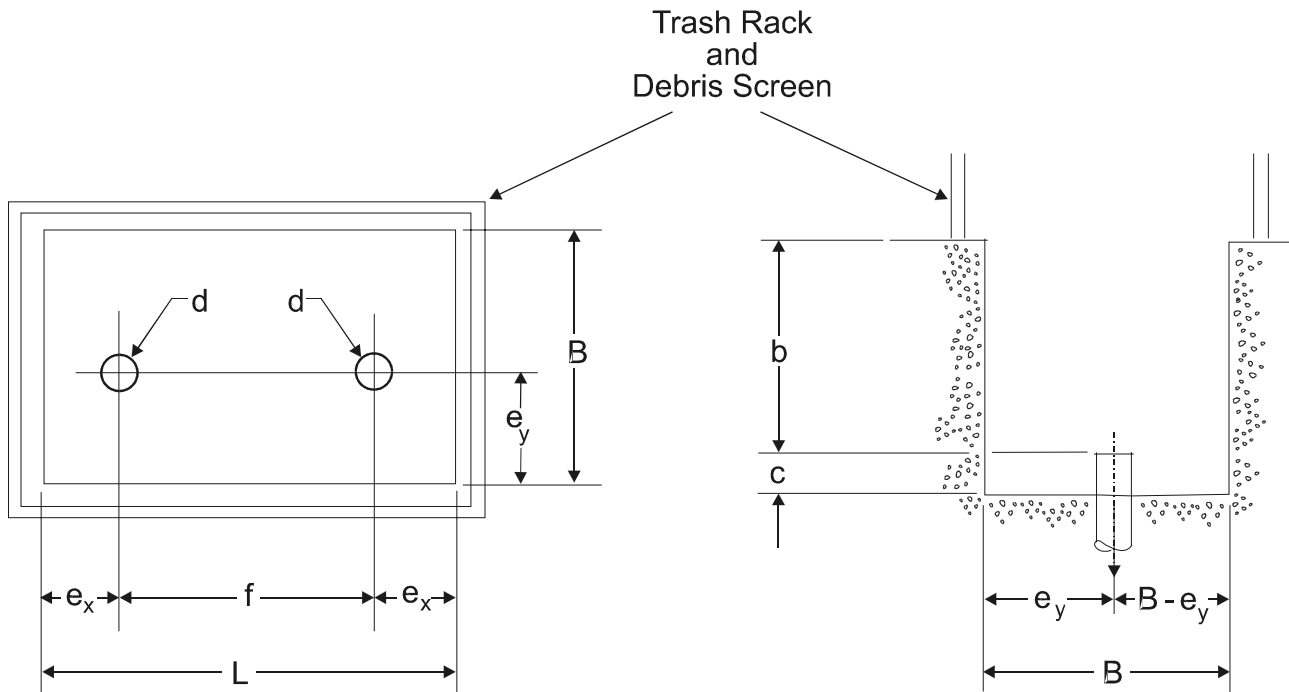

TABLE A-4

ADDITIONAL GUIDELINES RELATED TO SUMP SIZE AND PLACEMENT

1. The clearance between the trash rack and any wall or obstruction of length ℓ equal to or greater than the length of the adjacent screen/grate (B_s or L_s) should be at least 4 feet (1.2 meters).
2. A solid wall or large obstruction may form the boundary of the sump on one side only, i.e., the sump must have three sides open to the approach flow.
3. These additional guidelines should be followed to ensure the validity of the data in Tables A-1, A-2, A-3.1, and A-3.2.

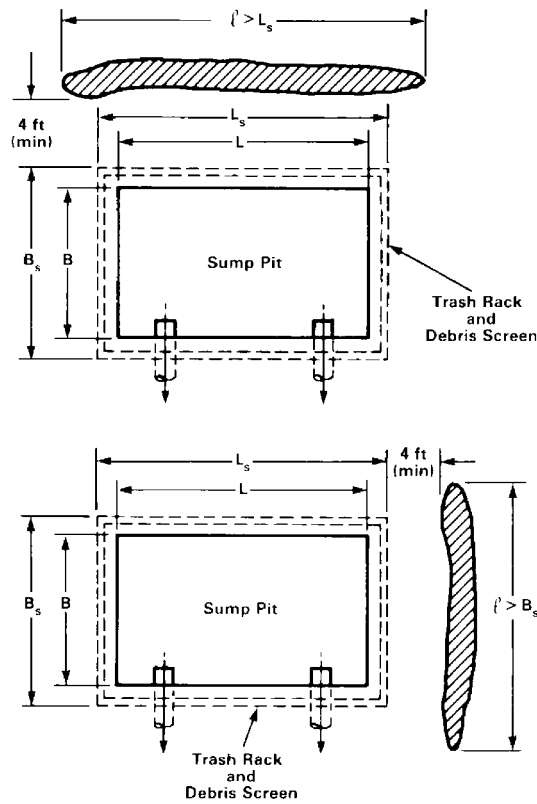

TABLE A-5

PWR DESIGN GUIDELINES FOR VERTICAL INTERCEPTORS AND COVER PLATE

1. Minimum height of interceptors should be 2 feet (0.61 meters).
2. Distance from sump side to screens, g_s , may be any reasonable value.
3. Screen mesh size (see Regulatory Position 1.1.1.12)
4. Trash racks should be vertically or nearly vertically oriented 1- to 1½-inch (25- to 38-mm) standard floor grate or equivalent.
5. The distance between the debris screens and trash racks should be 6 inches (15.2 cm) or less.
6. A solid cover plate should be mounted above the sump and should fully cover the trash rack. The cover plate should be designed to ensure the release of air trapped below the plate (a plate located below the minimum water level is preferable).

NOTE: See NUREG-0897.

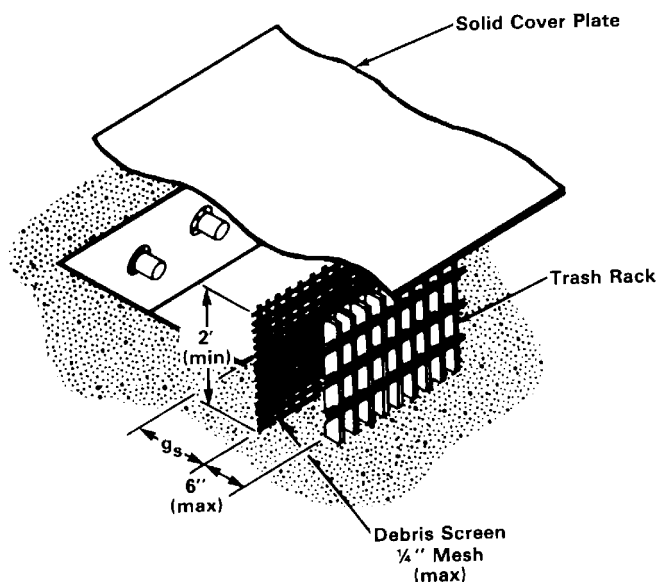

TABLE A-6

PWR GUIDELINES FOR SELECTED VORTEX SUPPRESSORS

1. Cubic arrangement of standard 1½-inch (30-mm) deep or deeper floor grating (or its equivalent) with a characteristic length, l_v , that is at least 3 pipe diameters and with the top of the cube submerged at least 6 inches (15.2 cm) below the minimum water level. Noncubic designs with $l_v > 3$ pipe diameters for the horizontal upper grate and satisfying the depth and distances to the minimum water level given for cubic designs are acceptable.
2. Standard 1½-inch (38-mm) or deeper floor grating (or its equivalent) located horizontally over the entire sump and containment floor inside the screens and located below the lip of the sump pit.

NOTE: Tests on these types of vortex suppressors at Alden Research Laboratory have demonstrated their capability to reduce air ingestion to zero even under the most adverse conditions simulated.

Design #1:

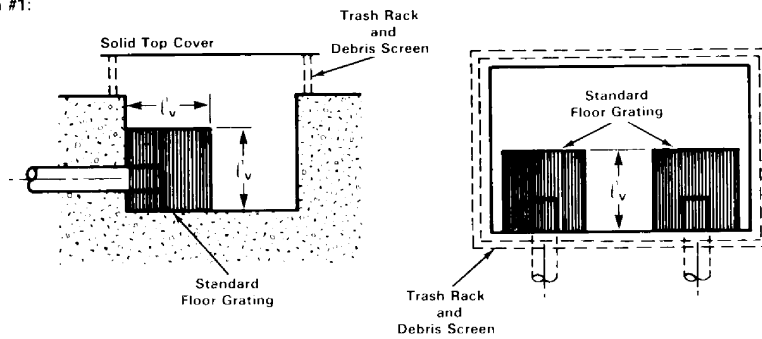

Design #2:

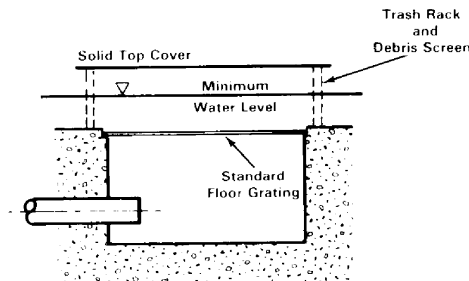

APPENDIX A REFERENCES

ANSI/HI 1.1-1.5 1994, "American National Standard for Centrifugal Pumps for Nomenclature, Definitions, Application and Operation," Section 1.3.3.1.16.2, "NPSH Margin Considerations," American National Standards Institute, 1994.

NUREG-0897, A.W. Serkiz, "Containment Emergency Sump Performance (Technical Findings Related to Unresolved Safety Issue A-43)," Revision 1, USNRC, October 1985.¹

NUREG/CR-2772, M. Padmanabhan, "Hydraulic Performance of Pump Suction Inlets for Emergency Core Cooling Systems in Boiling Water Reactors" (ARL-398A), USNRC, June 1982.¹

NUREG/CR-2982, D.N. Brocard, "Buoyancy, Transport, and Head Loss of Fibrous Reactor Insulation" (SAND82-7205), Revision 1, USNRC, July 1983.¹

NUREG/CR-3170, W.W. Durgin and J. Noreika, "The Susceptibility of Fibrous Insulation Pillows to Debris Formation Under Exposure to Energetic Jet Flows" (SAND83-7008), USNRC, March 1983.¹

NUREG/CR-3394, J.J. Wysocki, "Probabilistic Assessment of Recirculation Sump Blockage Due to Loss-of-Coolant Accidents," Volumes 1 and 2 (SAND83-7116), USNRC, July 1983.¹

NUREG/CR-3616, D.N. Brocard, "Transport and Screen Blockage Characteristics of Reflective Metallic Insulation Materials" (SAND83-7471), USNRC, January 1984.¹

NUREG/CR-6224, G. Zigler et al., "Parametric Study of the Potential for BWR ECCS Strainer Blockage Due to LOCA Generated Debris" (SEA No. 93-554-06-A:1), USNRC, October 1995.¹

NUREG/CR-6772, "GSI-191: Separate-Effects Characterization of Debris Transport in Water," USNRC, August 2002.¹

NUREG/CR-6773, "GSI-191: Integrated Debris Transport Tests in Water Using Simulated Containment Floor Geometries," USNRC, December 2002.¹

¹ Copies are available at current rates from the U.S. Government Printing Office, P.O. Box 37082, Washington, DC 20402-9328 (telephone (202)512-1800); or from the National Technical Information Service by writing NTIS at 5285 Port Royal Road, Springfield, VA 22161; (telephone (703)487-4650; <<http://www.ntis.gov/ordernow>>. Copies are available for inspection or copying for a fee from the NRC Public Document Room at 11555 Rockville Pike, Rockville, MD; the PDR's mailing address is USNRC PDR, Washington, DC 20555; telephone (301)415-4737 or (800)397-4209; fax (301)415-3548; email is PDR@NRC.GOV.

APPENDIX B

EXAMPLES OF ACTIVE MITIGATION SYSTEMS

In-Line (or Pipeline) Strainer

A strainer installed in the piping system, upstream of equipment, that will remove harmful objects and particulates from the fluid stream by a backwashing action.

Self-Cleaning Strainer

A strainer that is used upstream of equipment to filter out harmful objects and particulates and is designed to clean itself without the aid of external help.

Strainer Backwashing System

A system designed to dislodge objects and particulates from the surface of a strainer by directing a fluid stream in the opposite direction of the flow through the strainer.

REGULATORY ANALYSIS

A separate regulatory analysis was not prepared for this proposed Revision 3 of Regulatory Guide 1.82 since the guide is being revised to clarify guidance for pressurized water reactors and to make minor changes to guidance for boiling water reactors; the guide continues to be intended to provide guidance on methods acceptable to the NRC staff for evaluating the adequacy of ECCS sump performance for recirculation cooling following a loss-of-coolant accident. Therefore, a new regulatory analysis is not needed.

In addition, the pertinent guidance in Regulatory Guide 1.1, also referred to as NRC Safety Guide 1, "Net Positive Suction Head For Emergency Core Cooling and Containment Heat Removal System Pumps," is incorporated into this Revision 3 of Regulatory Guide 1.82. Generic Letter 97-04, "Assurance of Sufficient Net Positive Suction Head for Emergency Core Cooling and Containment Heat Removal Pumps," dated October 7, 1997, requested licensees of nuclear power plants to respond to several questions related to the net positive suction head of the ECCS and containment heat removal system pumps in their power plants. The NRC staff reviewed these responses and wrote letters to the licensee of each power plant to provide the staff's conclusions based on these reviews. Based on its review of GL 97-04 responses, the staff determined that all operating plants satisfy the guidance in Safety Guide 1. The criteria used for these reviews were discussed in the generic letter and its regulatory analysis, in meetings with the NRC's Committee to Review Generic Requirements and Advisory Committee on Reactor Safeguards, and with licensees during the NRC's review of the generic letter responses. These criteria are now incorporated into this Revision 3 of Regulatory Guide 1.82. The portion of the guidance related to the use of containment pressure for the determination of available net positive suction head is taken from the guidance in Safety Guide 1.